

Introduction 003

About Us 005

Preservation and Handling of
Hot Line Tools 006

Basic Maintenance of Hot Line Tools. 006

Characteristics of Hot Line Tools 007

Using Hot Line Tools 007

Glossary 008

Reference Index 011

PRODUCT GROUP

A Grounding Equipment 019	F Load Lifting Tools and Accessories 177
B Hand Sticks, Hot Sticks and Universal Tools 075	G Conductor Support Equipment 199
C Cover-Up and Insulating Rubber. 113	H Bare-Hand Equipment 259
D Tool Repair and Storage 137	I Instruments 267
E Ladders, Platforms and Insulating Scaffold. 147	J Temporary Jumpers 281
	L Daylight Warning Spheres 297

INTRODUCTION

PRECAUTIONS FOR HOT LINE TOOLS

The hot line tools described in this catalog must be handled, installed, and stored only by trained personnel who are familiar with the operating procedures and in compliance with applicable safety standards.

The information contained in this catalog and any other information in the instruction manuals shall under no circumstances replace proper training and experience in safety procedures. In addition, they do not cover all details on the tools, nor cover every possible situation concerning tool installation, operation, and maintenance.

For further information or special requests not included in this catalog, Ritz should be contacted to assist in developing the most viable solution.

Ritz Ferramentas is continually looking for ways to improve its products and services. Therefore, the information in this catalog may be changed without prior notice, always in view of the total safety of electricians involved in the maintenance activities in electrical systems.

HOT LINE WORKING METHODS

The great need to avoid undesirable power maintenance shutdowns required the development of safe techniques and practices for uninterrupted power supply, without negatively affecting generation, transmission, and distribution utilities. Not only financially, but also regarding how these utilities are seen by their consumers.

The numberless services to be performed in different voltage classes and different types of electrical installations, such as transmission lines, substations and distribution networks, have encouraged the development of tools, as well as unique and situation-specific working methods, depending on the type and location of the tasks to be performed and even the criteria defined by each utility.

Now the electrical system has three hot line working methods that can be applied in many voltage classes, provided electrician teams are properly trained and have proper tools, personal protective equipment (PPE), and collective protective equipment (CPE).

1° METHOD - HOT STICK METHOD

In this method, the first to be developed, the electrician performs operations using tools attached to the end of an insulating stick. This method is designed for work on all voltage classes.

For voltages up to 69 kV, where phase distances are shorter, conductors are removed from their original position by means of support poles, clamps etc.

The entire hot line toolkit is designed to make it easier for electricians to move around structures with total safety.

In this method the electrician must strictly observe the phase-to-phase and phase-phase minimum safety distance according to the table.

Rated Voltage (kV)	Phase-ground distance (m)	Phase-phase distance (m)
0.05 a 1.0	Avoid contact	Avoid contact
1.1 a 15	0.64	0.66
15.1 a 36	0.72	0.77
36.1 a 46	0.77	0,85
46.1 a 72.5	0.90	1.05
72.6 a 121	0.95	1.29
138 a 145	1.09	1.50
161 a 169	1.22	1.71
230 a 242	1.59	2.27
245 a 326	2.59	3.80
500 a 550	3.42	5.50
765 a 800	4.53	7.91

The recommended safety distances in this table are in accordance with OSHA publication on 01/31/1994.

2° METHOD - RUBBER GLOVE METHOD

This method comprises of protecting the electrician with gloves and appropriate insulating sleeves (PPE), positioned on a platform, scaffold, ladder, or man basket, performing the services with protected hands.

The entire work area is also protected with insulating covers (CPE) and, during the tasks, the space strictly necessary for operation is uncovered. This rules out the chances of electricians or work components (conductors, tools) touching or approaching two points of different potentials, causing a short circuit.

This method is only used for distribution networks and substations with voltages up to 35 kV.

3° METHOD - BAREHAND METHOD

The purpose of this method is to allow for greater maintenance resources, especially on high to ultra-high voltage transmission lines where safety distances are greater, as well as substations of 60 kV and more.

Barehand work is based on the Faraday Cage principle and consists of direct contact of the electrician with the energized conductor.

To protect against electric field effects, the electrician wears a conductive suit over his/her body, leaving only part of his/her face uncovered.

When near energized conductors, the electrician connects this suit to a conductor, and then it will be at the same potential as the installation.

For insulating protection and locomotion of the earth potential to the energized installation potential, Ritz currently has several insulating equipment for each type of installation, such as ladders, chairs, insulating extensions, scaffolding, and others.

Before each use, these equipments must be submitted to voltage tests, using the energized conductor at hand as voltage source and measuring the leakage current must be monitored by a micro ammeter - Micro-Tester (RC402-0288) - installed between the bottom end of the equipment and the ground point, to check its insulating conditions in accordance with the leakage current values established by standard.

For field tests of insulating equipment, using a portable electric pole tester (Ritz Tester) is also recommended as another important certification measure of insulating conditions of this equipment before each use.

As with the Hot-Stick Work Method, the Barehand Work Method requires strict observance of phase-ground and phase-phase safety distances, especially in substation interventions where these distances are reduced.

ABOUT US

Ritz Ferramentas has specialized for over 55 years in the design and manufacture of tools and equipment for maintenance work on de-energized and energized electrical systems. We have a complete portfolio of tools for maintenance work on live lines up to 800 kV AC and DC for work on electrical systems in contact, distance and potential methods, meeting Brazilian, international and ISO 9001 standards.

Pioneer in the manufacture of live line tools in Brazil, it developed its first tubes reinforced with fiberglass for maintenance in energized networks in 1968, with the manufacture of the so-called Hot Sticks, as it already had a wide knowledge of this technology in the manufacture of insulating parts for application in small oil volume circuit breakers. In 1971, Ritz produced the first complete set of tools for maintenance on energized networks.

Between 1973 and 1989, the association with A.B. Chance Company, world leader in the segment. The association generated an exchange of know-how and process innovation, making Ritz recognized worldwide for its quality, safety, reliability and excellence.

In 2011, another new stage began for the company, with the acquisition by the North American multinational Terex. This provided an evolution and improvement in processes, methodologies, layout, technology, safety, skills, results and the conquest of new international markets.

In 2021, in line with the tradition and reference of the Ritz brand, the shareholding control of the company passed into the hands of a company formed by a group of managers from the predecessor Ritz Ferramentas, maintaining and strengthening the commitment to continue the trajectory of development and innovation that are important marks of its legacy.

QUALITY REFERENCE

RITZGLAS® glass fiber reinforced tubes, a Ritz trademark, are internationally recognized for their quality and reliability. RITZGLAS® tubes are subjected to tests based on ASTM F-711 and IEC 60855 standards.



RITZGLAS® Insulating Tube, a critical integral part of most Ritz live line tools, has a core of single-cell polyurethane foam internally, which prevents moisture or dirt from absorbing and condensation. Its external construction consists of highly treated glass fibers arranged in a circumferential and longitudinal direction and impregnated with epoxy resin of a special formulation.

RITZGLAS® tube has high dielectric strength, mechanical strength and low weight, essential characteristics for live-line tools.

The orange of the RITZGLAS® pole is suitable for its good visibility in the work areas, considered an additional safety item for the electrician team.

PRESERVATION AND HANDLING OF HOT LINE TOOLS

Hot line tools require specific care for their protection in order to keep them available for immediate use. In addition, such care will result in prolonged tool life and consequently increased user safety and confidence.

As a rule, hot line tools should be kept dry. They should never be placed directly on the ground and should be stored in the vehicle or tool cart until the moment of use and then placed on a support (stick rack). Tools may only be placed on previously covered soil with a clean, dry tarpaulin to protect them from direct contact with dust or moisture.

Due to the nature of the application and the variable severity under which live-line tools are subjected, we suggest the following regarding their use condition:

- a. Visual inspection before each use;
- b. Mechanical tests with the application of the rated load of the tools, with a periodicity to be defined by the user, which should consider the severity of the previous uses;
- c. Periodic electrical testing as determined by international standards and NR-10.

Severity means: exposure of tools to excessive load; load imbalance; chemical corrosion by apparent and non-apparent chemical agents; impacts; improper maintenance (no gap treatment; poor lubrication; no replacement of worn components or replacement with components not approved by the manufacturer; localized malfunction in a component that could compromise an entire toolkit etc.); improper storage and packaging for transport and storage etc.

BASIC MAINTENANCE OF HOT LINE TOOLS

Hot-sticks under ideal conditions of use, require the following periodic care:

Cleaning the Hot-sticks

Most impurities are removed by wiping the stick with a dry cloth. If the stick is impregnated with grease, wipe it with a cloth soaked in isopropyl alcohol or EcoThinner that will not leave any residue. After being clean and dry, they are rubbed with a cloth for cleaning sticks, which is actually a cloth impregnated with substance to protect them. Then, the rod is electrically tested using the Ritz Tester pole tester. This should be done to check that all impurities have been removed.

Hot-stick repair

The gloss restorer should be applied only when it is evident that the coating film is in poor condition. Before applying the gloss restorer, dry the stick. Then use a fine sandpaper to remove the old gloss restorer. The stick should be cleaned again using the solvent and then dried with a clean cloth before gloss restorer application.

Rupture repair

If more than superficial damage is identified the rupture restorer may be used to fill the damaged area. Then use a fine sandpaper to remove excess restorer fluid. To use cracks and shine restorers, refer to our Stick and Pole Recovery Manual.

CHARACTERISTICS OF HOT LINE TOOLS

Live-line tools consist primarily of RITZGLAS® poles and metal parts in special aluminum and bronze alloys. Given the nature of their application, where safety standards are implicitly contained in the working standards themselves, these tools are manufactured under strict quality control, from raw material selection to final reception testing.

RITZGLAS® poles are electrically tested during manufacture with 100 kV every 30 cm in accordance with ASTM F-711.

The aluminum parts are heat treated under strict temperature control in order to preserve the physical properties of the basic material as much as possible.

No new type of tool is available to the market without type testing to ensure its constructive and operational design characteristics.

USING HOT LINE TOOLS

Prior to each use, live line tools must be visually inspected and electrically tested, which can be done by the user. Before being carried to the electricians on the structure, the tools should be cleaned using a dry cloth and then a stick cleaning cloth. During these cleaning operations, a visual inspection of the metal and insulating parts can be carried out



IMPORTANT

Maintenance of live-line tools should be treated as a critical process and manufacturer recommendations must be strictly followed.

GLOSSARY

For the better understanding of the reader about the definitions, units of measure, symbols, abbreviations, and keywords addressed in this catalog, we present a brief description of their meanings.

DEFINITIONS

Extra-strength laminated aluminum

Aluminum alloy plates used in the construction of some yoke models to make them light and sturdy. These yokes are characterized by their construction with plain plates construction.

Jaws Opening Capacity

Limit measures (minimum and maximum) adopted for closing and opening the grounding clamps and some insulating poles, compatible with the cable and conductor sizes that will be used.

Rated Current Capacity

Current withstand unit of an electrical conductor during a given operating time. In our case, the cables used in temporary grounding and hot line jumpers.

Work Load Capacity

Maximum workload value set for hot line tools (defined in daN). The values for these loads are specified in this catalog.

Balanced Maximum Load

When tensile forces or loads are evenly distributed over the lifting equipment.

Unbalanced Maximum Load

When tensile forces or loads are unevenly distributed over the lifting equipment, thus reducing its rated capacity.

Shear

Application of two forces in opposite directions, converging, with the same direction and perpendicular to the axis of a body, tending to divide it into two parts.

Catenary

Uniform curve assumed by a body (e.g. cable) when suspended by its two ends (pole) and under the sole action of its own weight.

Work Length

Useful distance between tool coupling points (energized side and de-energized side).

Insulating Length

Safety distance limit for each hot line tool. This length is usually located between the point of contact with the energized part and the electrician's holding point (or de-energized part).

Total Length

Distance between ends of a hot line tool.

Phase-to-phase distance

Minimum distance between two phases, with different potentials in the same circuit.

Phase-to-ground distance

Minimum distance between an energized and a de-energized part of an electrical installation.

Tracking effect

Irreversible degradation caused by the formation of paths that start and develop on the surface of an insulating material, being favorable to electric current conduction through these paths, even when dry.

Structures

Buildings such as towers, poles of wood, concrete or steel to support electricity conductors, so that the electrical power can be transported over long distances.

Bending

Application of perpendicular forces to the axis of a body, which is supported by one or two points.

Faraday's Cage

Physics Principle, developed by Michael Faraday (1791-1867), where inside an enclosed conductive surface the electric field is null. In order to shield and protect the electrician against the effect of an electric field when in contact with the potential, conductive clothing is used.

Electrical Interventions

Maintenance performed on electrical systems, in order to continue the transmission of electricity through specific procedures and by qualified persons.

Handling

Manually using hot line tools or other instruments.

Jaw

Moving part of grounding clamps, yokes, or insulating poles for the purpose of securing the conductor or various couplings.

Usually these jaws are driven by turning the clamping screws (for grounding clamps) or the pole itself.

Operate

Using hot line equipment or other instruments in interventions on energized installations, within the procedures and characteristics of each product.

Low Voltage Networks (LV)

Circuits exceeding 50 volts, equal to or less than 1 kV, between phases or between phases and ground.

Medium-Voltage Network (MV)

Circuits with voltages above 1 kV to 50 kV, which generally distribute the power received from transmission systems to large, medium, and small consumers.

High Voltage Networks (HV)

Circuits with voltages above 50 kV up to 230 kV, responsible for transporting electricity from production to consumption centers.

Extra High Voltage Networks (EHV)

Circuits with voltages above 230 kV to 750 kV, also responsible for transporting electricity from production centers to consumption centers, usually over longer distances.

Ultra High Voltage Networks (UHV)

Circuits with voltages above 750 kV, also responsible for transporting electricity from production centers to consumption centers, usually over greater distances.

Dielectric strength

Higher electric field value of an insulating tool without it becoming a conductor.

This dielectric strength varies from tool to tool, for example: in the case of air, its dielectric strength is about 3.0 kV/mm. Thus, when an electric field in the air exceeds this value, it ceases to be insulating and becomes conductive.

Rated Voltage

Maximum allowable electrical voltage value for work on insulating equipment.

Traction

Application of forces acting perpendicular to the cross section of a body and with the same direction, but in opposite directions, tending to lengthen it.

Torsion

Applying a circular force to the end of a body that tends to deform it.

Torque

A vector quantity defined as the fraction of a force applied to an object, which is effectively used to rotate around an axis or center point, known as a pivot point. As an example, in the grounding clamps, the torque is applied to the clamping screws, whose values are in this catalog and defined in daN.m.

Thermal treatment

A process by which cast aluminum components and/or parts are subjected to high temperature treatment in order to increase their mechanical strength.

Use Tools in line

Installing two or more tools sequentially for the purpose of increasing isolation in the intervention. Example: Use of a nylon strap coupled to an insulating pole for hoists and blocks.

UNIT OF MEASUREMENT

Ampere (A)

Electrical current measurement unit that, with an electromotive force of 1 Volt it travels a circuit with a resistance of 1 Ohm.

AWG

American Wire Gauge, American denomination used for wire gauges (thickness). The standard metric series in mm² is currently used in Brazil.

CA

Brazilian Identification Unit for bare wire cross-sections without steel core. (equivalent to ASC).

CAA

Brazilian identification unit for steel core aluminum bare wire cross-section (equivalent to ACSR).

Kcmil ACSR (circular mil)

A circular mil is the area of a circle with a diameter of one thousandth of an inch. This is one of the units adopted for wire or cable cross-sections.

daN (decaNewtons)

A unit adopted by ABNT for forces exerted on hot line tools. (According to ABNT (Brazilian Technical Standards Association), 1 daN is considered 1 kgf kilogram-force).

Kilovolt (kV)

Electrical voltage unit equivalent to 1x10³ V.

Volt (V)

Unit of electrical voltage, potential difference or electromotive force. It corresponds to the voltage that, applied over the 1 Ohm resistance, produces the 1 amp current.

SYMBOLS / ABBREVIATIONS

∅ (diameter)

Geometric figure with same midpoints of parallel strings to designate the circular measurement of a given tool.

®

Trademark of a product or process of a particular company.

ATR

Abbreviation used by Ritz to designate Temporary Grounding.

FLV

Abbreviation used by Ritz to designate hot line Tools.

NBI (Basic Insulation Level)

Value (in kV) that a device must withstand when applying a voltage pulse for a given time without changing its insulating characteristics.

RITZGLAS®

Ritz trademark for the insulating fiberglass pipe, which is a fundamental integral part of most live-line tools.

Catalog Reference	Page	Catalog Reference	Page	Catalog Reference	Page	Catalog Reference	Page
1500E	181	ATR09962-1	142	ATR17455-1	41	COB11176-3	118
3000E	181	ATR10777-1	61	ATR17456-1	37	COB11176-4	118
51.E07.D20-CE	197	ATR10994-1	97	ATR17457-1	35	COB11400-1	122
51.E07.D30-CE	197	ATR11627-1	54	ATR17459-1	54	COB11612-1	125
51.E07.D40-CE	197	ATR11627-2	64	ATR17460-1	55	COB11617-1	126
51.E07.D50-CE	197	ATR12407-1	40	ATR17461-1	55	COB11622-1	126
6000E	181	ATR13036-2	67	ATR17462-1	55	COB11721-1	127
750E	181	ATR13036-8	68	ATR17572-1	38	COB13345-1	120
ATR00137-1	73	ATR13043-1	27	ATR17574-1	72	COB13559-1	127
ATR00137-2	73	ATR13047-1	57	ATR18867-1	69	COB14780-1	119
ATR00137-3	73	ATR13047-2	57	ATR19433-1	55	COB14959-1	127
ATR00395-8	48	ATR13147-1	51	ATR20763-1	39	COB18644-1	127
ATR00548-1	26	ATR13159-1	60	ATR21918-2	28	COB19874-1	128
ATR01726-3	65	ATR13628-1	57	ATR23989-1	49	COB20663-1	126
ATR01875-1	49	ATR14442-1	69	ATR26446-2	68	COB20664-1	126
ATR03308-2	58	ATR14477-1	70	ATR26446-3	68	COB22404-1	125
ATR03318-1	70	ATR14484-1	142	ATR26446-4	68	COB24863-1	128
ATR03402-1	73	ATR14484-2	142	ATR26446-5	68	COB24885-1	128
ATR03641-1	71	ATR15508-2	28	ATR26446-6	68	COB24891-1	128
ATR03653-1	57	ATR16843-1	142	ATR26555-1	72	COB26095-1	125
ATR03654-2	29	ATR16843-2	142	ATR30260-1	30	COB28494-1	120
ATR04116-1	69	ATR16843-3	142	ATR30783-1	34	COB30064-1	124
ATR04514-1	24	ATR16843-4	142	ATR30985-1	174	CT 0,07-1	275
ATR04514-2	24	ATR16843-5	142	COB03333-1	123	CT 10-40/SB	275
ATR04631-1	33	ATR16843-6	142	COB03335-1	122	CT 180-540/SB	275
ATR04694-1	69	ATR16843-7	142	COB04487-1	118	CT 20-80/SB	275
ATR08814-1	73	ATR17179-2	67	COB04487-2	118	CT 2-8/SB	275
ATR08814-2	73	ATR17179-8	68	COB04487-3	118	CT 3,8-36/SB	275
ATR08814-3	73	ATR17184-2	67	COB04487-4	118	CT 60-240/SB	275
ATR08814-4	73	ATR17184-8	68	COB08835-1	123	CTC-25	66
ATR08947-1	56	ATR17185-2	67	COB10765-1	119	CTC-35	66
ATR08969-1	51	ATR17185-8	68	COB11047-1	124	CTC-50	66
ATR08969-2	51	ATR17348-1	56	COB11050-1	124	CTC-70	66
ATR08969-3	51	ATR17439-1	25	COB11051-1	124	CTC-95	66
ATR08969-4	51	ATR17439-2	25	COB11147-1	124	CT-CC 0,5-5	277
ATR08969-5	51	ATR17440-1	42	COB11170-1	124	CT-CSU-10-40	276
ATR08969-6	51	ATR17440-2	43	COB11170-2	124	CT-CSU-3,8-36/SB	276
ATR08969-7	51	ATR17441-1	44	COB11173-1	119	CT-RS/C 2-6	276
ATR09033-1	56	ATR17442-1	45	COB11173-2	119	CT-RS/C 3,8-36	276
ATR09729-1	32	ATR17454-1	46	COB11176-1	118	DMU-15	277
ATR09734-2	31	ATR17454-2	47	COB11176-2	118	DMU-25	277

Catalog Reference	Page	Catalog Reference	Page	Catalog Reference	Page	Catalog Reference	Page
DMU-36/SB	277	ES/PU-41-CN-SB	150	ET/LV-37	162	FLV05992-1	170
EA/PR-12/PD	152	ES/PU-44-CN-SB	150	ET/LV-46	162	FLV06052-1	168
EA/PR-15/PD	152	ES/PU-47-CN-SB	150	ET/LV-59	162	FLV06423-1	164
EA/PR-21/PD	152	ES/PU-50-CN-SB	150	ETM/01	153	FLV06619-1	197
EA/PR-27/PD	152	ES/PU-53-CN-SB	150	ETM/02	153	FLV06619-2	197
EA/PR-34/PD	152	ES/PU-56-CN-SB	150	ETM/03	153	FLV06619-3	197
EA/PR-40/PD	152	ES/PU-59-CN-SB	150	ETM/04	153	FLV07777-1	193
EA/PR-52/PD	152	ES/PU-62-CN-SB	150	ETM/05	153	FLV08257-3	184
EE/LV-108-CN-SB	161	ES/PU-65-CN-SB	150	ETM/06	153	FLV08958-1	78
EE/LV-120-CN-SB	161	ESC15051-1	172	ETM/07	153	FLV08958-2	78
EE/LV-96-CN-SB	161	ESC15051-2	172	ETM/08	153	FLV08958-3	78
EE/PR-12/58-CN-SM	151	ESC15051-3	172	ETM/09	153	FLV08958-4	78
EE/PR-12/70-CN-SM	151	ESR11795-1	301	ETM/10	153	FLV08958-5	78
EE/PR-12/82-CN-SM	151	ESR12591-1	301	ETM/11	153	FLV09012-1	172
EE/PR-15/10-CN-SM	151	ESR12963-1	301	ETM/12	153	FLV09091-1	168
EE/PR-15/11-CN-SM	151	ESR12981-1	301	ETM/13	153	FLV09311-1	108
EE/PR-15/14-CN-SM	151	ESR19899-1	301	ETM/14	153	FLV09429-1	111
EE/PR-15/95-CN-SM	151	ESR19899-2	301	FLV00196-5	189	FLV10460-1	241
EE/PU-35-CN-SB	150	ESR19899-3	301	FLV00714-2	215	FLV10893-1	193
EE/PU-41-CN-SB	150	ESR19899-4	301	FLV01121-4	93	FLV11042-1	104
EE/PU-47-CN-SB	150	ESR19899-5	301	FLV01644-1	189	FLV11179-1	290
EE/PU-53-CN-SB	150	ESR19899-6	301	FLV01852-1	255	FLV11179-2	290
EE/PU-59-CN-SB	150	ESR19899-7	301	FLV02544-1	265	FLV11179-3	290
EE/PU-65-CN-SB	150	ESR19899-8	301	FLV02818-1	105	FLV11179-4	290
EE/PU-71-CN-SB	150	ESR19900-1	302	FLV03102-1	146	FLV11179-5	290
EE/PU-77-CN-SB	150	ESR19900-2	302	FLV03278-3	301	FLV11179-6	290
EE/PU-84-CN-SB	150	ESR19900-3	302	FLV03457-13	216	FLV11404-1	279
EE/PU-90-CN-SB	150	ESR19900-4	302	FLV03457-2	255	FLV11537-1	238
EE/PU-97-CN-SB	150	ESR19900-5	302	FLV03457-3	255	FLV11554-1	86
ES/LV-28-CN-SB	161	ESR19900-6	302	FLV03457-5	255	FLV11623-1	126
ES/LV-37-CN-SB	161	ESR19900-7	302	FLV03457-6	255	FLV12192-1	232
ES/LV-46-CN-SB	161	ESR19900-8	302	FLV03460-1	255	FLV12240-1	235
ES/LV-59-CN-SB	161	ESR30700-1	300	FLV03550-2	160	FLV12240-2	235
ES/PR-8/27-CN-SM	151	ESR30700-2	300	FLV03550-6	160	FLV12409-1	294
ES/PR-8/40-CN-SM	151	ESR30700-3	300	FLV03550-7	160	FLV12563-1	263
ES/PR-8/46-CN-SM	151	ESR30700-4	300	FLV03811-3	102	FLV13006-1	233
ES/PR-8/58-CN-SM	151	ESR30700-5	300	FLV04803-1	192	FLV13006-2	233
ES/PU-29-CN-SB	150	ESR30700-6	300	FLV04803-2	192	FLV13006-3	233
ES/PU-32-CN-SB	150	ESR30700-7	300	FLV04803-3	192	FLV13033-1	293
ES/PU-35-CN-SB	150	ESR30700-8	300	FLV05613-1	216	FLV13045-1	293
ES/PU-38-CN-SB	150	ET/LV-28	162	FLV05784-1	291	FLV13130-1	232

Catalog Reference	Page	Catalog Reference	Page	Catalog Reference	Page	Catalog Reference	Page
FLV13352-1	232	FLV17443-6	287	FLV18339-14	145	FLV28201-1	296
FLV13356-1	232	FLV17443-7	287	FLV18339-15	145	FLV29023-1	226
FLV13780-1	232	FLV17443-8	287	FLV18339-16	145	FLV29023-2	226
FLV13872-1	86	FLV17444-1	169	FLV18339-17	145	FLV29023-3	226
FLV13907-1	108	FLV17444-2	169	FLV18339-2	145	FLV29023-4	226
FLV13916-1	168	FLV17444-3	169	FLV18339-3	145	FLV29023-5	226
FLV13917-1	292	FLV17445-1	251	FLV18339-4	145	FLV29374-1	294
FLV14342-1	172	FLV17446-1	252	FLV18339-5	145	FLV29374-2	294
FLV14342-2	172	FLV17447-1	252	FLV18339-6	145	FLV29611-1	105
FLV14342-3	172	FLV17448-1	289	FLV18339-7	145	FLV29635-1	195
FLV15444-1	173	FLV17449-1	289	FLV18339-8	145	FLV29780-1	294
FLV16054-1	241	FLV17450-1	230	FLV18339-9	145	FLV29842-1	262
FLV16140-1	112	FLV17453-1	252	FLV18375-1	173	FLV29842-2	262
FLV16146-1	112	FLV17458-1	251	FLV18593-1	255	FLV29842-3	262
FLV16148-1	104	FLV17496-1	171	FLV18593-2	255	FLV29842-4	262
FLV16159-1	104	FLV17648-1	173	FLV18593-3	255	FLV30045-1	218
FLV16165-1	103	FLV17755-1	240	FLV18593-4	252	FLV30047-1	292
FLV16193-1	243	FLV17844-1	107	FLV18594-1	255	FLV30049-1	294
FLV16237-1	171	FLV17928-1	216	FLV18594-2	255	FLV30058-1	220
FLV16237-2	171	FLV17928-2	216	FLV18594-3	255	FLV30173-1	108
FLV16238-1	171	FLV18133-1	189	FLV18594-4	252	FLV30182-1	283
FLV16241-1	168	FLV18158-1	296	FLV18595-1	255	FLV30182-2	283
FLV16241-2	168	FLV18158-2	296	FLV18595-2	255	FLV30182-3	283
FLV16241-3	168	FLV18158-3	296	FLV18595-3	255	FLV30339-1	284
FLV16241-4	168	FLV18158-4	296	FLV18617-1	188	FLV30339-2	284
FLV16241-5	168	FLV18158-5	296	FLV19067-1	251	FLV30463-1	283
FLV16241-6	171	FLV18158-6	296	FLV19192-1	74	FLV30463-2	283
FLV16241-7	171	FLV18161-1	296	FLV19245-1	105	FLV30463-3	283
FLV16364-1	141	FLV18169-1	173	FLV19286-1	233	FLV30489-1	175
FLV16599-1	207	FLV18169-2	173	FLV19286-2	233	FLV30490-1	175
FLV16813-1	193	FLV18170-1	296	FLV19769-1	222	FLV30535-1	285
FLV16886-1	129	FLV18171-1	296	FLV21045-1	264	FLV30577-3	239
FLV16886-2	129	FLV18198-1	157	FLV21130-1	296	FLV30577-4	239
FLV17172-1	296	FLV18199-1	157	FLV21133-1	296	FLV30595-1	162
FLV17173-1	296	FLV18200-1	157	FLV21310-1	216	FLV30620-1	262
FLV17436-1	163	FLV18269-1	173	FLV21310-2	216	FLV30620-2	262
FLV17443-1	287	FLV18339-1	145	FLV21504-1	165	FLV30620-3	262
FLV17443-2	287	FLV18339-10	145	FLV21549-1	264	FLV30620-4	262
FLV17443-3	287	FLV18339-11	145	FLV23916-1	173	FLV30622-1	262
FLV17443-4	287	FLV18339-12	145	FLV25726-1	296	FLV30623-1	262
FLV17443-5	287	FLV18339-13	145	FLV25886-1	296	FLV30669-1	239

Catalog Reference	Page	Catalog Reference	Page	Catalog Reference	Page	Catalog Reference	Page
FLV30707-1	175	FLX30500-1	131	NHL 60-240	274	RC400-0562	215
FLV30722-1	175	FLX30500-2	131	R059738	241	RC400-0574	221
FLV30752-1	287	FLX30500-3	131	R066780	91	RC400-0575	221
FLV30752-2	287	FLX30500-4	131	R068922	252	RC400-0578	183
FLV30752-3	287	FLX30500-5	131	R070184	252	RC400-0602	189
FLV30752-4	287	FLX30500-6	131	R070496	189	RC400-0612	226
FLV30752-5	287	FLX30501-1	131	R2230-1	195	RC400-0613	226
FLV30752-6	287	FLX30501-2	131	R2230-2	195	RC400-0812	224
FLV30752-7	287	FLX30501-3	131	R3641	283	RC400-0813	224
FLV30752-8	287	FLX30501-4	131	R3861	283	RC400-0814	223
FLV30752-9	287	FLX30501-5	131	R3863	283	RC400-0815	223
FLV30755-1	97	FLX30501-6	131	R3866	283	RC400-0816	223
FLV30765-2	286	FLX30502-1	131	RC200T	109	RC400-0817	223
FLV30765-3	286	FLX30502-2	131	RC305-0008	109	RC400-0818	223
FLV30765-4	286	FLX30504-1	131	RC305-0021	109	RC400-0914	193
FLV30841-1	110	FLX30504-2	131	RC309-0323	180	RC400-0915	193
FLV30994-2	286	FLX30504-3	131	RC309-0451	180	RC400-0916	193
FLV30994-3	286	FLX30504-4	131	RC309-0452	180	RC400-0917	193
FLV30994-4	286	FLX30504-5	131	RC309-0467	180	RC400-0918	193
FLV31089-1	159	FLX30505-1	131	RC309-0468	180	RC400-0919	193
FLV31217-1	87	FLX30505-2	131	RC312-0000	180	RC400-0925	193
FLV31240-1	170	FLX30505-3	131	RC400-0073	211	RC400-1016	209
FLV31240-2	170	FLX30505-4	131	RC400-0075	213	RC400-1175	182
FLV31240-3	170	FLX30505-5	131	RC400-0090	183	RC400-1310	217
FLV31340-1	170	FVR BXQ-Z-40A	109	RC400-0152	257	RC400-1509	220
FLV31340-2	170	H1876/B-AFT	270	RC400-0171	204	RC400-2399	182
FLV31349-1	239	H1990/ST-138	278	RC400-0172	204	RC400-2400	182
FLV31351-1	239	H1990/ST-800	278	RC400-0268	217	RC401-0003	246
FLV400-0219	247	LIR-BLR	129	RC400-0269	217	RC401-0015	252
FLV4740-10W	209	LR-4/II	129	RC400-0315	183	RC401-0095	245
FLV4740-15W	209	LR-SP-4/II	129	RC400-0331	215	RC401-0155	246
FLV4740-16W	209	LR-SP-4/II-30396	129	RC400-0445	247	RC401-0168	248
FLV4740-17W	209	LR-TP-4/II	129	RC400-0464	187	RC401-0354	254
FLV4740-18W	209	LS-80	272	RC400-0465	187	RC401-0355	254
FLV4740-19W	209	LS-80/WD	272	RC400-0469	187	RC401-0356	254
FLV4740-20W	209	LS-81	272	RC400-0470	185	RC401-0357	254
FLV4740-3W	209	LS-81/WD	272	RC400-0472	185	RC401-0358	254
FLV4740-4W	209	MD800	273	RC400-0475	185	RC401-0359	254
FLV4740-5W	209	NHL 10-40	274	RC400-0483	185	RC401-0361	255
FLV4740-9W	209	NHL 10-40/GR	274	RC400-0517	220	RC401-0362	255
FLV4783-22	247	NHL 20-80	274	RC400-0546	257	RC401-0410	235

Catalog Reference	Page	Catalog Reference	Page	Catalog Reference	Page	Catalog Reference	Page
RC401-0411	235	RC403-0177	97	RC406-0181GA	122	RC600-0862	65
RC401-0455	255	RC403-0184	93	RC406-0182	122	RC600-0965	62
RC401-0758	229	RC403-0185	93	RC406-0182L	122	RC600-1584	72
RC401-1717	246	RC403-0186	93	RC406-0514GA	122	RC600-1617	64
RC401-1718	246	RC403-0291	78	RC406-0548	117	RC600-1732	61
RC401-1719	246	RC403-0292	78	RC406-0549	117	RC600-1743	59
RC401-1720	244	RC403-0293	78	RC406-0557	122	RC600-1895	291
RC401-1721	245	RC403-0294	78	RC406-0557L	122	RC600-1944	291
RC401-1722	248	RC403-0295	78	RC417-0122/5	262	RC600-2231	64
RC401-2144	228	RC403-0296	78	RC417-0123/5	262	RC600-2282	62
RC401-2145	228	RC403-0297	78	RC417-0124	262	RC600-2300	52
RC401-2146	228	RC403-0298	78	RC417-0125	262	RC600-2316	53
RC401-2147	228	RC403-0299	78	RC417-0126	262	RC600-2598	284
RC401-2148	228	RC403-0314	97	RC417-0126/5	262	RC600-2599	284
RC401-2149	228	RC403-0320	103	RC417-0133	196	RC600-2600	284
RC401-2174	237	RC403-0342	78	RC417-0134	196	RC600-2601	284
RC401-2175	237	RC403-0343	78	RC417-0135	196	RC600-2602	67
RC401-2176	237	RC403-0377	79	RC417-0136	196	RC600-2603	67
RC401-2177	237	RC403-0378	79	RC417-0137	196	RC600-2604	67
RC401-2178	237	RC403-0450	103	RC417-0138	196	RC600-2605	67
RC401-2179	237	RC403-0834	97	RC417-0139	196	RC600-2606	68
RC401-2215	228	RC403-1071	97	RC417-0140	196	RC600-2607	68
RC401-2216	237	RC403-1085	91	RC417-0141	196	RC600-2608	68
RC402-0139	159	RC403-1085M	91	RC417-0142	196	RC600-2609	68
RC402-0140	159	RC403-1382	106	RC417-0143	196	RC600-2610	67
RC402-0277	165	RC403-1384	106	RC417-0144	141	RC600-2611	67
RC402-0288	273	RC403-1416	97	RC417-0146	141	RC600-2612	67
RC402-0402	156	RC403-1417	97	RC417-0623	262	RC600-2613	67
RC402-0404	156	RC403-2136	90	RC417-0624	262	RC600-2614	68
RC402-0407	156	RC403-2270	102	RC417-0624/5	262	RC600-2615	68
RC402-0411	156	RC403-3068	92	RC417-0625/5	262	RC600-2616	68
RC402-0418	156	RC403-3069	92	RC417-6067	195	RC600-2617	68
RC402-0421	156	RC406-0000	117	RC600-0000	249	RC600-2618	67
RC402-0422	156	RC406-0009	120	RC600-0065	59	RC600-2619	67
RC402-0482	156	RC406-0028	117	RC600-0080	71	RC600-2620	67
RC402-0790	256	RC406-0029	117	RC600-0085	63	RC600-2621	67
RC403-0005	96	RC406-0030	117	RC600-0152	70	RC600-2622	68
RC403-0006	96	RC406-0046	123	RC600-0337	58	RC600-2623	68
RC403-001	96	RC406-0097	120	RC600-0386	62	RC600-2624	68
RC403-0126	96	RC406-0102	119	RC600-0434	59	RC600-2625	68
RC403-0175	96	RC406-0164	122	RC600-0861	65	RC600-2626	67

Catalog Reference	Page	Catalog Reference	Page	Catalog Reference	Page	Catalog Reference	Page
RC600-2627	67	RG3626	71	RH1891-6.	90	RH4718-1.	223
RC600-2628	67	RG4228-10SJ	61	RH1917	140	RH4718-2.	223
RC600-2629	67	RG4229-15J	60	RH1950-9.	252	RH4718-3.	223
RC600-2630	68	RG4754-1.	72	RH1950-90.	253	RH4718-4.	223
RC600-2631	68	RH1760	88	RH1968-8.	94	RH4719-114	242
RC600-2632	68	RH1760-1.	88	RH1973/H-10	189	RH4719-84.	242
RC600-2633	68	RH1760-10.	88	RH1973-814.	189	RH4719-96.	242
RC601-0013	290	RH1760-12.	88	RH1978-8.	94	RH4720-114	242
RC601-0171	286	RH1760-14.	88	RH20	184	RH4720-84.	242
RC601-0172	286	RH1760-2.	88	RH2106-4.	107	RH4720-96.	242
RC601-0173	286	RH1760-3.	88	RH4540	251	RH4721-112	257
RC601-0174	286	RH1760-4.	88	RH4540-1.	251	RH4722	224
RE400-0008	215	RH1760-6.	88	RH4540-2.	251	RH4723-2.	257
RE400-0009	215	RH1761	89	RH4540-3.	251	RH4723-4.	257
RE400-0434	185	RH1761-1.	89	RH4540-4.	251	RH4785-1.	240
RE401-0138	241	RH1770	89	RH4645-10.	204	RH4785-2.	240
RE401-1510	241	RH1790-10.	89	RH4645-6.	204	RH4785-3.	240
RE401-1998	240	RH1790-12.	89	RH4645-8.	204	RH4794	248
RE401-2066	240	RH1790-14.	89	RH4646-10.	204	RH4794-1.	248
RE401-2068	240	RH1790-8.	89	RH4646-12.	204	RH4794-2.	248
RE402-0087	159	RH1840-10.	251	RH4646-6.	204	RH4800-60.	217
RE402-0092	160	RH1840-12.	251	RH4646-8.	204	RH4800-72.	217
RE402-0099	159	RH1840-4.	251	RH4647-10.	204	RH4809-W	220
RE402-0138	159	RH1840-6.	251	RH4647-12.	204	RH4862-51.	216
RE402-0141	160	RH1840-8.	251	RH4647-14.	204	RH4862-6.	216
RE402-0525	159	RH1855-25.	89	RH4647-16.	204	RH4862-8.	216
RE402-0526	159	RH1855-26.	89	RH4647-8.	204	RH4903-10.	155
RE402-0568	159	RH1861-1.	91	RH4710-4.	243	RH4903-12.	155
RE402-0569	159	RH1861-2.	91	RH4714-4.	225	RH4903-8.	155
RE403-2543P	79	RH1871-4.	106	RH4714-6.	225	RH4904-1.	160
RG3363-1.	63	RH1871-6.	106	RH4715-1.	223	RH4904-10.	155
RG3363-4SJ	63	RH1873-4.	106	RH4715-2.	223	RH4904-12.	155
RG3367-2.	58	RH1873-6.	106	RH4716-1.	223	RH4904-14.	155
RG3368	58	RH1875-4.	106	RH4716-2.	223	RH4904-16.	155
RG3369	58	RH1875-6.	106	RH4716-3.	223	RH4904-8.	155
RG3403	54	RH1876	270	RH4716-4.	223	RH4905-1.	160
RG3403T	54	RH1876-1.	270	RH4716-5.	223	RH4905-10.	155
RG3622-1.	59	RH1876-2.	270	RH4716-6.	223	RH4905-12.	155
RG3622-1T.	64	RH1876-4.	270	RH4717	223	RH4905-14.	155
RG3622-2.	59	RH1891-2.	90	RH4717-1.	223	RH4905-16.	155
RG3625	71	RH1891-3.	90	RH4718	223	RH4905-18.	155

Catalog Reference	Page	Catalog Reference	Page	Catalog Reference	Page	Catalog Reference	Page
RH4905-20.	155	RM2946-1	244	RM4455-85	102	RM4937-6	117
RH4905-8.	155	RM2946-12	245	RM4455-86	103	RM4946.	122
RH4924-1.	160	RM4455-10	98	RM4455-87	96	RM4947.	122
RH4925-1.	160	RM4455-100.	104	RM4455-88	103	RM4948.	123
RH4945-1.	160	RM4455-102.	104	RM4455-89	103	RP406-0184	122
RH4964-6W	164	RM4455-103.	104	RM4455-9	98	RS1600-7.	292
RHG4228-16SJ	61	RM4455-12	98	RM4455-92	103	RT-110	272
RHG4229-6SJ	60	RM4455-13	98	RM4455-93	103	RT-220	272
RHG4230-1	249	RM4455-15	98	RM4455-96	104	RT306-0014	198
RM1728-5	215	RM4455-17	99	RM4455-97	104	RT400-0025	240
RM1729.	205	RM4455-18	99	RM4660.	95	RT400-0803	139
RM1729-1	205	RM4455-19	99	RM4660-E1	95	RT400-0838	247
RM1729-2	205	RM4455-2	98	RM4724-1	243	RT400-0870	184
RM1729-3	205	RM4455-22	99	RM4740.	211	RT400-1413	212
RM1846-W.	209	RM4455-23	99	RM4740-14	211	RT400-1939	220
RM1847.	211	RM4455-26A	99	RM4741-1	211	RT400-1940	220
RM1847-3	211	RM4455-28	99	RM4741-2	211	RT400-2007	220
RM1847-4	211	RM4455-29B.	99	RM4741-3	211	RT400-2272	220
RM1847-6	211	RM4455-36	100	RM4741-5	211	RT401-0573	246
RM1848-W.	211	RM4455-37	100	RM4742.	212	RT401-0689	248
RM1849.	195	RM4455-38	100	RM4742-1	212	RT401-0935	245
RM1860.	95	RM4455-39	100	RM4742-2	212	RT402-0030	164
RM1867.	79	RM4455-40	100	RM4742-3	212	RT402-0423	156
RM1889.	100	RM4455-46	100	RM4743.	206	RT402-0899	160
RM1895-1	190	RM4455-5	98	RM4743-1	206	RT402-0900	160
RM1895-2	190	RM4455-50	100	RM4743-2	206	RT402-0901	160
RM1895-3	190	RM4455-6	98	RM4744.	209	RT403-0752	89
RM1895-4	190	RM4455-63	100	RM4745.	207	RT403-1101	101
RM1895-5	190	RM4455-64	101	RM4745-1	207	RT403-2417	217
RM1896-2	191	RM4455-66	99	RM4745-2	207	RT600-0641	36
RM1896-3	191	RM4455-67	101	RM4760-1W	209	RT600-0891	50
RM1896-4	191	RM4455-69	101	RM4760-2	211	RT600-2321	52
RM1897-50	191	RM4455-70	101	RM4760-W	209	RT601-0039	284
RM1897-100.	191	RM4455-71	101	RM4805-15	215	RT601-0281	288
RM1897-200.	191	RM4455-72	101	RM4805-16	216	RT601-0282	288
RM1897-250.	191	RM4455-77	101	RM4805-17	215	RT601-0283	288
RM1904.	140	RM4455-78	101	RM4931.	123	RT601-0284	288
RM1909.	140	RM4455-79	102	RM4933.	119	RT601-0285	288
RM1947-1	246	RM4455-80	102	RM4937-1	117	RT601-0286	288
RM1948-3	241	RM4455-82	102	RM4937-2	117	RT601-0287	288
RM1979.	195	RM4455-84	102	RM4937-4	117	RT601-0288	288

Catalog Reference	Page	Catalog Reference	Page	Catalog Reference	Page	Catalog Reference	Page
RTZ-14-00-10	132	RTZ-14-2-9,5	133	RV401-0157	240	VMR-70/L	85
RTZ-14-00-10,5	132	RTZ-14-3-10	133	RV401-0158	240	VMR-90	85
RTZ-14-00-11	132	RTZ-14-3-10,5	133	SLT-2/3	143	VMR-90/L	85
RTZ-14-00-11,5	132	RTZ-14-3-11	133	SLT-4/5	143	VMR-I	84
RTZ-14-00-12	132	RTZ-14-3-11,5	133	SLT-6/7	143	VMR-P	84
RTZ-14-00-8	132	RTZ-14-3-12	133	SLT-8/9	143	VMR-S	84
RTZ-14-00-8,5	132	RTZ-14-3-8	133	TILV-16/AFT	271	VTT 28790-1/9	83
RTZ-14-00-9	132	RTZ-14-3-8,5	133	TILV-16/DT	271	VTT 29537-1/2	83
RTZ-14-00-9,5	132	RTZ-14-3-9	133	VMR/L-I	84	VTT 29537-1/3	83
RTZ-14-0-10	132	RTZ-14-3-9,5	133	VMR/L-P	84	VTT 29537-1/4	83
RTZ-14-0-10,5	132	RTZ-14-4-10	133	VMR/L-S	84	VTT 29537-1/5	83
RTZ-14-0-11	132	RTZ-14-4-10,5	133	VMR/S-SP	49	VTT 29537-1/6	83
RTZ-14-0-11,5	132	RTZ-14-4-11	133	VMR00884-1	87	VTT 29537-1/7	83
RTZ-14-0-12	132	RTZ-14-4-11,5	133	VMR01479-2	87	VTT 29537-1/8	83
RTZ-14-0-8	132	RTZ-14-4-12	133	VMR02579-1	86	VTT-1/2	80
RTZ-14-0-8,5	132	RTZ-14-4-8	133	VMR03414-1	87	VTT-1/3	80
RTZ-14-0-9	132	RTZ-14-4-8,5	133	VMR07205-1	86	VTT-1/4	80
RTZ-14-0-9,5	132	RTZ-14-4-9	133	VMR08974-1	87	VTT-1/5	80
RTZ-14-1-10	132	RTZ-14-4-9,5	133	VMR10484-1	144	VTT-1/5-1800	80
RTZ-14-1-10,5	132	RTZ-LA-0-M	134	VMR10484-2	144	VTT-1/6	80
RTZ-14-1-11	132	RTZ-LA-1-M	134	VMR10484-3	144	VTT-1/7	80
RTZ-14-1-11,5	132	RTZ-LA-2-G	134	VMR11560-1	87	VTT-1/8	80
RTZ-14-1-12	132	RTZ-LA-2-M	134	VMR-15	85	VTT-1/9	80
RTZ-14-1-8	132	RTZ-LA-3-G	134	VMR-15/L	85	VTT17182-5	143
RTZ-14-1-8,5	132	RTZ-LA-3-M	134	VMR16483-1	87	VTT17182-6	143
RTZ-14-1-9	132	RTZ-LA-4-G	134	VMR16824-1	144	VTT17182-7	143
RTZ-14-1-9,5	132	RTZ-LA-4-M	134	VMR16824-2	144	VTT-3HD/4	82
RTZ-14-2-10	133	RTZ-PR-0-M	134	VMR16825-1	144	VTT-3HD/5	82
RTZ-14-2-10,5	133	RTZ-PR-1-M	134	VMR16825-2	144	VTT-3HD/6	82
RTZ-14-2-11	133	RTZ-PR-2-G	134	VMR16826-1	144	VTT-3HD/7	82
RTZ-14-2-11,5	133	RTZ-PR-2-M	134	VMR-30	85	VTT-3HD/8	82
RTZ-14-2-12	133	RTZ-PR-3-G	134	VMR-30/L	85	VTT-3HD/9	82
RTZ-14-2-8	133	RTZ-PR-3-M	134	VMR-45	85		
RTZ-14-2-8,5	133	RTZ-PR-4-G	134	VMR-45/L	85		
RTZ-14-2-9	133	RTZ-PR-4-M	134	VMR-70	85		

GROUP A



Access our site.



GROUNDING EQUIPMENT



Temporary Grounding Set	021	Grounding Clamp	051
Low Voltage Grounding Sets.....	024	Copper Cables for Grounding.....	066
Medium Voltage Grounding Sets	029	Ground Cable Ferrule.....	066
High Voltage Grounding Sets.....	044	Grounding Cluster.....	069
Lifting and Installation Tool for Substation Grounding	049	Saddle-Type Cluster	070
Static Grounding Set	050	Auxiliary Equipment.....	071
		Hot Line Clamp.....	074

GROUP A

GROUNDING EQUIPMENT



TEMPORARY GROUNDING SET

A

An effective electrical connection equipment with intentional low impedance grounding, designed to ensure and maintain equipotential bonding during interventions in the electrical installation, protecting workers from accidental energization.

A proper specification of the temporary grounding set (ATR) is the first principle to ensure efficiency and safety in performing de-energized line work if the system is accidentally energized. Such specification must match the characteristics of the electrical installation where the Temporary Grounding Set will be installed.



CAREFULLY

Read the following basic requirements for the correct specification of the Temporary Grounding Set to ensure electrician safety.

For the specification of the ATR, the following characteristics of the electrical installations must be known before using it:

- a.** Installation type and voltage level:
 - Overhead network or line (kV);
 - Substation (kV);
 - Secondary Network (LV) with bare or shielded cable;
 - Underground network (kV);
- b.** Maximum short-circuit current;
- c.** Protection system actuation time;
- d.** Structure Type:
 - Metal;
 - Concrete;
 - Wood;
- e.** Phase-to-phase and phase-to-ground distances;
- f.** Phase and ground conductor sections where the ATR will be installed.

Maintenance on powered off overhead networks is, at first glance, an apparently safe condition to carry out the work. However, they may be mistakenly energized by several common factors:

- Operational errors;
- Accidental contact with other live circuits;
- Voltages induced by adjacent lines;
- Lightning discharges, even if distant from the workplace;
- Third-party power sources

Unfortunately, the factors described here are not theoretical facts, or even impossible to occur, as maintenance workers tend to imagine. This is because practice has shown us the truth through numberless accidents that occur every year at electric companies.

Temporary grounding and shorting are the main protection of people working on de-energized lines so they must be seen as their main work tool.

NOTE



The short-circuit current rating of the set is limited to the specified grounding and shorting cable cross-section.

The cable specification may have its cross-section (mm²) and/or length changed, both to increase or to decrease it, according to the short-circuit power of the electrical system where the set will be used.

Typical installation sequence of the temporary grounding set

- 1.** Check that the line is de-energized using the Voltage Detector mounted to the RITZGLAS® hot stick.
- 2.** Insert the Ground Screw Rod into the ground and connect the clamp (ground) to its rod. The screw rod must be inserted as deep as possible, leaving above the ground just enough space to connect the clamp.
- 3.** Using the RITZGLAS® Hot Stick and proceeding as in hot line work, the phase clamps must be slowly lifted and connected to the central phase.
- 4.** Using the RITZGLAS® Hot Stick, the second and third clamps must be connected to the side phases, which concludes the phase-to-ground interconnection.
- 5.** Only after installing the grounding set, must the electrician have access to the conductors. This is to say that a line can only be deemed de-energized after being properly grounded

LOW VOLTAGE GROUNDING SETS

Temporary Grounding Rod for Secondary Networks (LV)

The temporary grounding rod for secondary networks is used for maintenance services in de-energized low voltage overhead lines.

The electrician can use it to connect phase conductors to the neutral conductor simultaneously, shorting them with a single move.

This rod is constructed with a RITZGLAS® Ø 25 mm tube, aluminum jaws, and rubber storm skirt, delimiting the grip area.

The clamping jaws are connected to the conductor through compression springs, providing faster installation without damaging the conductors.

The aluminum bar used to interconnect the jaws has a screw at its lower end to connect a ground cable



ATR04514-2

ATR04514-1

TECHNICAL CHARACTERISTICS

Catalog Reference	ATR04514-1	ATR04514-2
Overall length (m)	1.40	1.20
Number of Jaws	5	4
Minimum Connection Capacity (mm)	Ø 3.50	Ø 3.50
Maximum Connection Capacity (mm)	Ø 19.50	Ø 19.50
Approximate weight (kg / lb)	1.40 / 3.09	1.10 / 2.43
Storage (optional)	ATR22128-1	ATR22128-2

Temporary Grounding Set for Conventional Secondary Networks (LV)

Maximum short-circuit current: 60 cycles - 5 kA

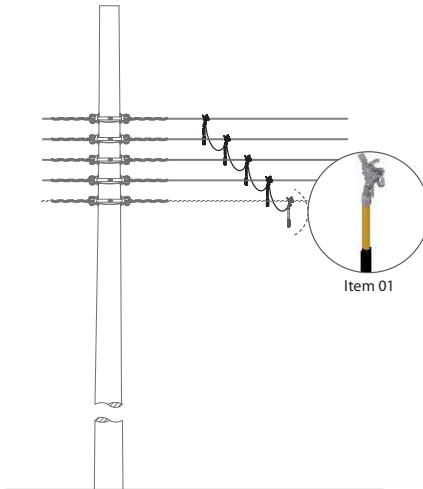

ATR17439-1

Item	Qty.	Unit.	Catalog Reference	Description
01	04	pc	ATR17348-1	Spring-loaded grounding clamp mounted to Ø 25 mm x 300 mm RITZGLAS® pole with rubber handle
02	1.20	m	CTC-25	Extra-flexible copper cable, 25 mm ² cross-section, with transparent PVC insulation, being three 400 mm length
03	06	pc	ATR26446-2	25 mm ² tin-plated copper cable lug
04	06	pc	ATR17923-4	Heat shrink
05	01	pc	ATR16843-7	Bag for storage and transport of the grounding set

ATR17439-2

Item	Qty.	Unit.	Catalog Reference	Description
01	05	pc	ATR17348-1	Spring-loaded grounding clamp mounted to Ø 25 mm x 300 mm RITZGLAS® pole with rubber handle
02	1.60	m	CTC-25	Extra-flexible copper cable, 25 mm ² cross-section, with transparent PVC insulation, being three 400 mm length
03	08	pc	ATR26446-2	25 mm ² tin-plated copper cable lug
04	08	pc	ATR17923-4	Heat shrink
05	01	pc	ATR16843-7	Bag for storage and transport of the grounding set

Temporary Grounding Set with Telescopic Hot Stick for Low Voltage (LV)

Maximum short-circuit current: 60 cycles - 5 kA

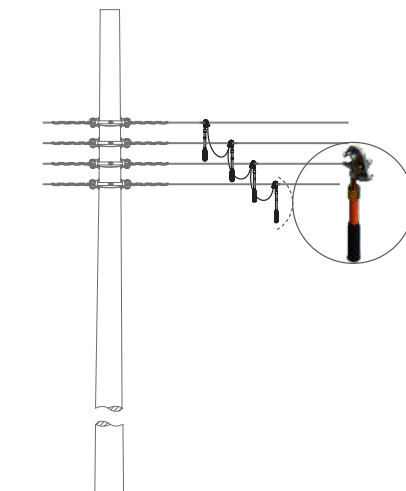

ATR00548-1

Item	Qty.	Unit.	Catalog Reference	Description
01	04	pc	ATR17459-1-E10	Twisting grounding clamp, fixed to 335mm long pole with long handle. Clamp opening: 4 to 22,5 mm
02	1,2	m	CTC-25	Extra-flexible copper cable, 25 mm ² cross-section, with transparent PVC insulation, being three of 0,4 m length
03	04	pc	ATR13036-2	25 mm ² plain shrouded aluminum ferrule
04	02	pc	ATR17184-2	25 mm ² threaded shrouded aluminum ferrule
05	06	pc	ATR17923-2	Heat shrink
06	01	pc	ATR16843-7	Bag for storage and transport of the grounding set

Secondary Networks (LV) Insulated with Multiplex and Conventional Cable with Bare Cable

Maximum short-circuit current: 60 cycles - 8 kA

This equipment enables quick, practical and safe installation and innovates the concept of grounding in LV multiplexed cables insulated systems or conventional systems.

Provided with pressure grounding clamps made of aluminum alloy and handles with rubber coating.

Equipped with tail connectors that can be installed on the system at pre-determined locations, using jumper piercing connectors, enabling the quick connection of the equipment to the system.

In order to increase safety of the installation, these tail connectors are provided with special terminals to protect the exposed connection points after the removal of the grounding set.



ATR13043-1

Item	Qty.	Unit.	Catalog Reference	Description
01	04	pc	ATR13047-1 ATR13047-2	Conductor-mounted spring-loaded grounding clamp with red plastic coated grip for phases (ATR13047-1) and black plastic coated grip for neutral (ATR13047-2).
02	1,50	m	CTC-35	Extra-flexible copper cable, 35 mm ² cross-section, with transparent PVC insulation, being three 500 mm length
03	06	pc	ATR26446-3	35 mm ² tin-plated copper cable lug
04	06	pc	ATR17923-5	Heat shrink
05	01	pc	ATR16818-1	Bag for storage and transport of the grounding set

NOTE

Ritz does not manufacture derivation piercing connectors. They must be purchased from third parties in quantities and sizes compatible with the conductors of the secondary network.

Temporary Grounding Equipment for Low Voltage MMCs

SMaximum short-circuit current: 15 cycles - 5 kA

The grounding equipment was designed for use at outlets of the Low Voltage Motor Control Center enclosures.



ATR15508-2

Body is made in RITZGLASS® to guarantee its light-weight, mechanical strength and electrical insulation, the equipment is provided with anatomical handles for firmer grip during the operation. Grounding cables 25 mm² are cooper with clear PVC jacket. Claws are made from highly conductive material, ground clamp with hex mobile "T", for use of 3/4" socket wrench. Set has a bag for transport and packaging.

TECHNICAL CHARACTERISTICS

Maximum working voltage (V)	1000	Rated current (A)	200
Cable size (mm ²)	25	Distance between contacts (mm)	60
Cable length (mm)	2500	Minimum enclosure depth (mm)	290
MMC outlet claw sizes (mm)	2 to 6	Range of the ground clamp [A] (mm)	4 to 9
Approximate mass (kg/lb)	1.85 / 4.09		

A

ATR21918-2

Body is made in RITZGLASS® to guarantee its light-weight, mechanical strength and electrical insulation, the equipment is provided with three anatomical handles for firmer grip during the operation. Grounding cables 25 mm² are cooper with clear PVC jacket, interconnected through the terminal block. Claws are made from highly conductive material, ground clamp with hex mobile "T", for use of 3/4" socket wrench. Set has a bag for transport and packaging.



TECHNICAL CHARACTERISTICS

Maximum working voltage (V)	1000	Rated current (A)	200
Cable size (mm ²)	25	Minimum distance between contacts (mm)	55
Cable length (mm)	2500	Length of cables to terminal block (mm)	1000
Minimum enclosure depth (mm)	290	Range of the ground clamp [A] (mm)	4 to 9
MCC outlet claw sizes (mm)	2 to 6	Approximate mass (kg/lb)	3.80 / 8.60

MEDIUM VOLTAGE GROUNDING SET

Temporary Grounding Set for Distribution Networks (MV)

Maximum short-circuit current: 60 cycles - 5 kA

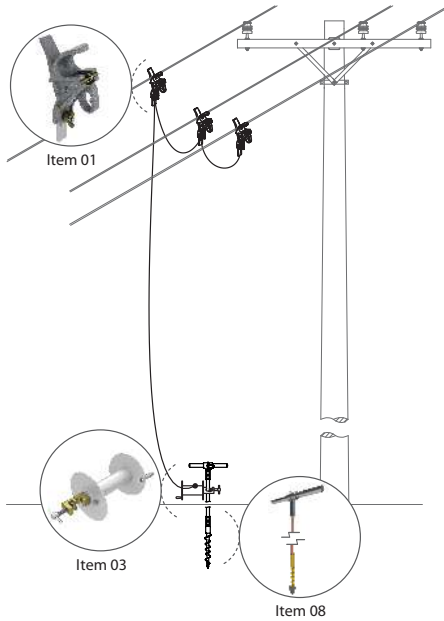

ATR03654-2

Item	Qty.	Unit.	Catalog Reference	Description
01	03	pc	ATR03653-1	Spring-loaded grounding clamp. Spring-loaded quick contact
02	01	pc	ATR04694-1	Cluster bar for clamp installation and removal operations
03	01	pc	ATR03641-1	Mounting reel, with bronze clamp, for connection to ground rod and storage of ground cable
04	16	m	CTC-25	Extra-flexible copper cable, 25 mm ² cross-section, with transparent PVC insulation, being two 2 m length and one 12 m length
05	06	pc	ATR26446-2	25 mm ² tin-plated copper cable lug
06	06	pc	ATR17923-4	Heat shrink
07	01	pc	VMR00884-1	Switching tool head
08	01	pc	ATR00137-2	Ø 17 mm x 1 m ground rod
09	01	pc	ATR16819-1	Bag for storage and transport of ground rod
10	01	pc	ATR16843-7	Bag for storage and transport of the grounding set

Temporary Grounding Set for Distribution Networks (MV)

Maximum short-circuit current: 60 cycles - 8 kA

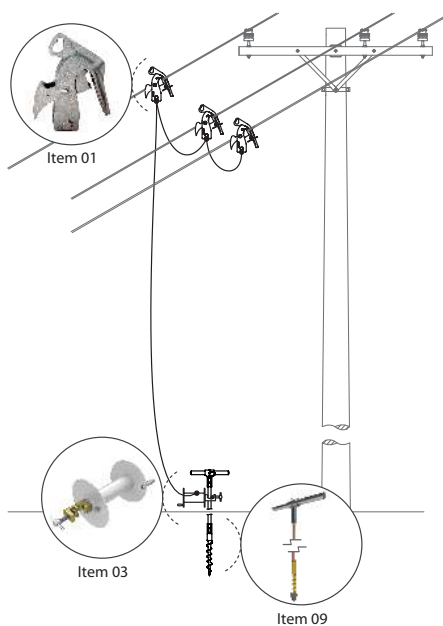

ATR30260-1

Item	Qty.	Unit.	Catalog Reference	Description
01	03	pc	ATR13628-1	Snap-on spring-loaded grounding clamp
02	01	pc	ATR14442-1	Cluster bar for clamp installation and removal operations
03	01	pc	ATR03641-1	Mounting reel, with bronze clamp, for connection to ground rod and storage of ground cable
04	4	m	CTC-35	Extra-flexible copper cable, 35 mm ² cross-section, with transparent PVC insulation, being two cable 2 m length
05	15	m	CTC-25	Extra-flexible copper cable, 25 mm ² , cross-section, with transparent PVC insulation, being one cable 15 m length
06	04	pc	ATR26446-3	35 mm ² tin-plated copper cable lug
07	02	pc	ATR26446-2	25 mm ² tin-plated copper cable lug
08	06	pc	ATR17923	Heat shrink
09	01	pc	ATR00137-2	Ø 17 mm x 1 m ground rod
10	01	pc	ATR16819-1	Bag for storage and transport of ground rod
11	01	pc	ATR16843-7	Bag for storage and transport of the grounding set

Temporary Grounding Set for Distribution Networks (MV)

Maximum short-circuit current: 60 cycles - 5 kA

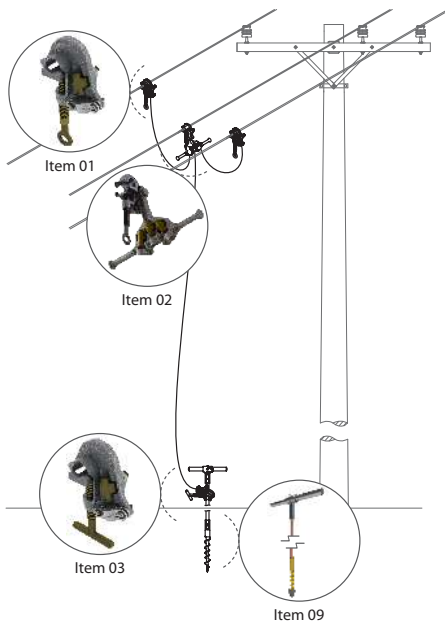

ATR09734-2

Item	Qty.	Unit.	Catalog Reference	Description
01	03	pc	RG3403	Twisting grounding clamp with eyescrew
02	01	pc	ATR04116-1	Cluster bar for simultaneous lifting of phase clamps
03	01	pc	RG3403T	Grounding clamp, with T-handle for connection to the ground point
04	16	m	CTC-25	Extra-flexible copper cable, 25 mm ² cross-section, with transparent PVC insulation, being two 2 m length and one 12 m length
05	06	pc	ATR13036-2	25 mm ² plain shrouded aluminum ferrule
06	06	pc	ATR17923-1	Heat shrink
07	01	pc	VMR07205-1	Tool head for grounding clamp
08	01	pc	VMR00884-1	Switching tool head
09	01	pc	ATR00137-2	Ø 17 mm x 1.0 m ground rod
10	01	pc	ATR16819-1	Bag for storage and transport of ground rod
11	01	pc	ATR09962-1	Bag for storage and transport of the grounding set

Temporary Grounding Set for Distribution Networks (MV)

Maximum short-circuit current: 60 cycles - 8 kA

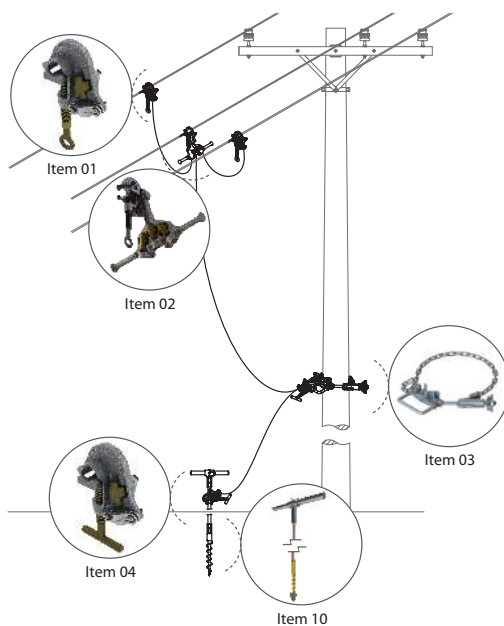

ATR09729-1

Item	Qty.	Unit.	Catalog Reference	Description
01	03	pc	RG3403	Twisting grounding clamp with eyescrew
02	01	pc	ATR04116-1	Cluster bar for simultaneous lifting of phase clamps
03	01	pc	ATR03318-1	Pole-mounted cluster bar, with wheel, for grounding intermediary point
04	03	pc	RG3403T	Grounding clamp with T-handle for connection to the ground point
05	17	m	CTC-35	Extra-flexible copper cable, 35 mm ² cross-section, with transparent PVC insulation, being two 2 m length, one 3 m length, and one 10 m length.
06	08	pc	RC600-2626	35 mm ² plain shrouded aluminum ferrule
07	08	pc	ATR17923-2	Heat shrink
08	01	pc	VMR07205-1	Tool head for grounding clamp
09	01	pc	VMR00884-1	Switching tool head
10	01	pc	ATR00137-2	Ø 17 mm x 1 m ground rod
11	01	pc	ATR16843-1	Bag for storage and transport of the grounding set

Temporary Grounding Set with Telescopic Hot Stick for Distribution Networks (MT)

Maximum short-circuit current: 60 cycles - 8 kA

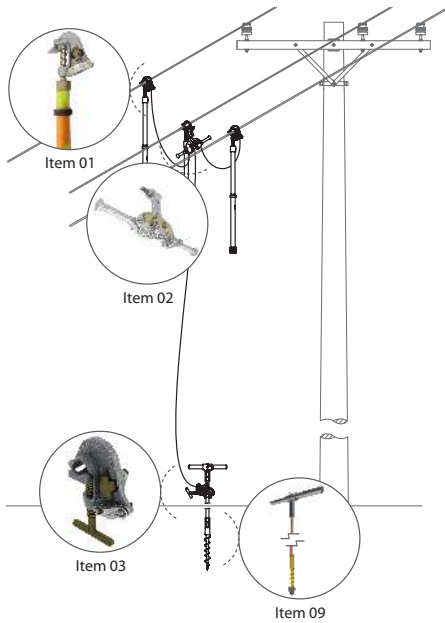

ATR04631-1

Item	Qty.	Unit.	Catalog Reference	Description
01	03	pc	ATR17460-1	Twisting grounding clamp mounted to telescopic hot stick extended length: 1.80 m
02	01	pc	ATR04116-1	Cluster bar for simultaneous lifting of phase clamps
03	01	pc	RG3403T	Grounding clamp with T-handle for connection to the ground point
04	04	m	CTC-35	Extra-flexible copper cable, 35 mm ² cross-section, with transparent PVC insulation, being two 2 m length
05	04	pc	RC600-2626	35 mm ² plain shrouded aluminum ferrule
06	10	m	CTC-25	Extra-flexible copper cable, 25 mm ² cross-section, with transparent PVC insulation, being one 10 m length
07	02	pc	ATR13036-2	25 mm ² plain shrouded aluminum ferrule
08	06	pc	ATR17923	Heat shrink
09	01	pc	ATR00137-2	Ø 17 mm x 1 m ground rod
10	01	pc	ATR16843-1	Bag for storage and transport of the grounding set

Temporary Grounding Set with RITZGLAS® tube for Distribution Networks (MT)

Maximum short-circuit current: 60 cycles - 8 kA

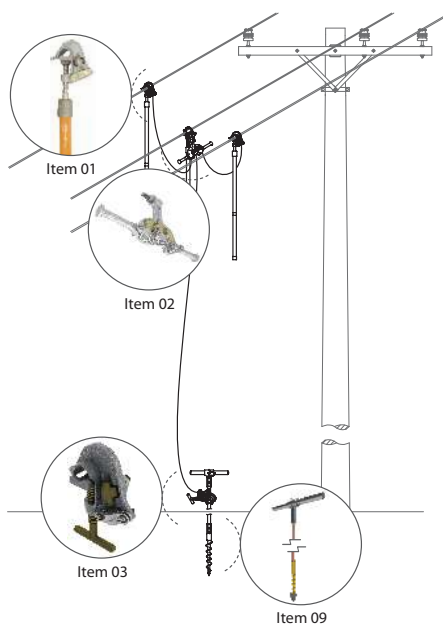

ATR30783-1

Item	Qty.	Unit.	Catalog Reference	Description
01	03	pc	ATR17459-1	Twisting grounding clamp mounted to RITZGLAS® tube length: 1.25 m
02	01	pc	ATR04116-1	Cluster bar for simultaneous lifting of phase clamps
03	01	pc	RG3403T	Grounding clamp with T-handle for connection to the ground point
04	16	m	CTC-35	Extra-flexible copper cable, 35 mm ² cross-section, with transparent PVC insulation, being one 12 m length and two of 2 m length
05	04	pc	RC600-2626	35 mm ² plain shrouded aluminum ferrule
06	06	pc	ATR17923	Heat shrink
07	01	pc	ATR00137-2	Ø 17 mm x 1 m ground rod
08	01	pc	ATR16843-1	Bag for storage and transport of the grounding set

Temporary Grounding Set with Telescopic Hot Stick for Distribution Networks (MT)

Maximum short-circuit current: 60 cycles - 8 kA

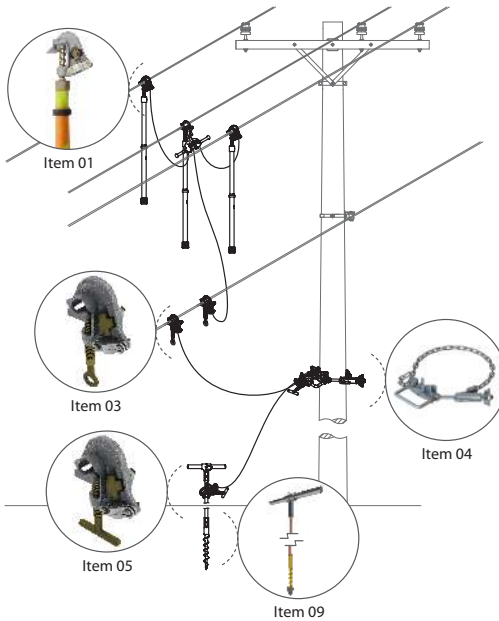

ATR17457-1

Item	Qty.	Unit.	Catalog Reference	Description
01	03	pc	ATR17462-1	Twisting grounding clamp mounted to telescopic hot stick and extended length: 2.59 m
02	01	pc	ATR04116-1	Cluster bar for simultaneous lifting of phase clamps
03	02	pc	RG3403	Twisting grounding clamp, with eyescrew, one for phase/neutral cable and one for neutral cable/saddle
04	01	pc	ATR03318-1	Pole-mounted cluster bar, with wheel, for grounding intermediary point
05	03	pc	RG3403T	Grounding clamp with T-handle for connection to the ground point
06	18	m	CTC-35	Extra-flexible copper cable, 35 mm ² cross-section, with transparent PVC insulation, being four 2 m length and one 10 m length
07	10	pc	RC600-2626	35 mm ² plain shrouded aluminum ferrule
08	10	pc	ATR17923-2	Heat shrink
09	01	pc	ATR00137-1	Ø 17 mm x 1.5 m ground rod
10	01	pc	ATR16843-2	Bag for storage and transport of the grounding set

Temporary Grounding Set for Distribution Overhead Lines (MT)

Maximum short-circuit current: 60 cycles - 8 kA

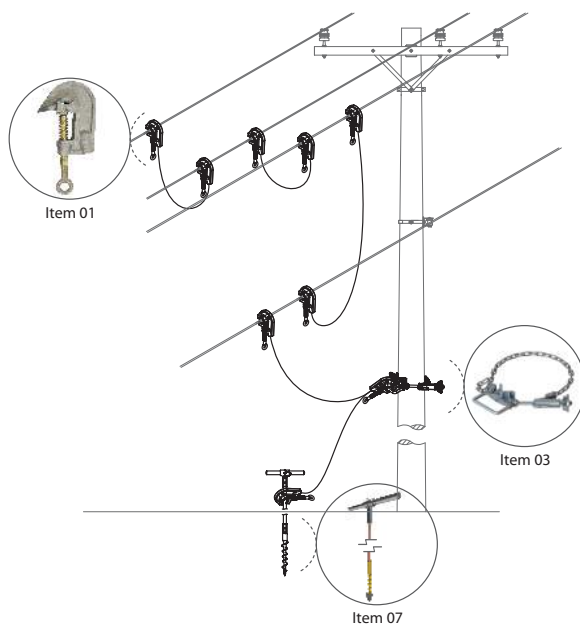

RT600-0641

Item	Qty.	Unit.	Catalog Reference	Description
01	10	pc	RC600-0065	Twisting grounding clamp with eyescrew and serrated jaw
02	03	pc	RC600-0080	Clamp resting support
03	01	pc	ATR03318-1	Pole-mounted cluster bar, with wheel, for grounding intermediary point
04	18,2	m	CTC-35	Extra-flexible copper cable, 35 mm ² cross-section, with transparent PVC insulation, being three 1.8 m length, one 3.6 m length, and one 9.2 m length
05	10	pc	RC600-2618	35 mm ² threaded shrouded aluminum ferrule
06	10	pc	ATR17923-2	Heat shrink
07	01	pc	ATR00137-1	Ø 17 mm x 1.5 m ground rod
08	01	pc	ATR16819-2	Bag for storage and transport of ground rod
09	01	pc	ATR09962-1	Bag for storage and transport of the grounding set

Temporary Grounding Set for Distribution Overhead Lines (MT)

Maximum short-circuit current: 60 cycles - 8 kA

This temporary grounding model is very versatile as it can be installed in different network configurations, such as: three-phase vertical and horizontal distribution and single-phase network.

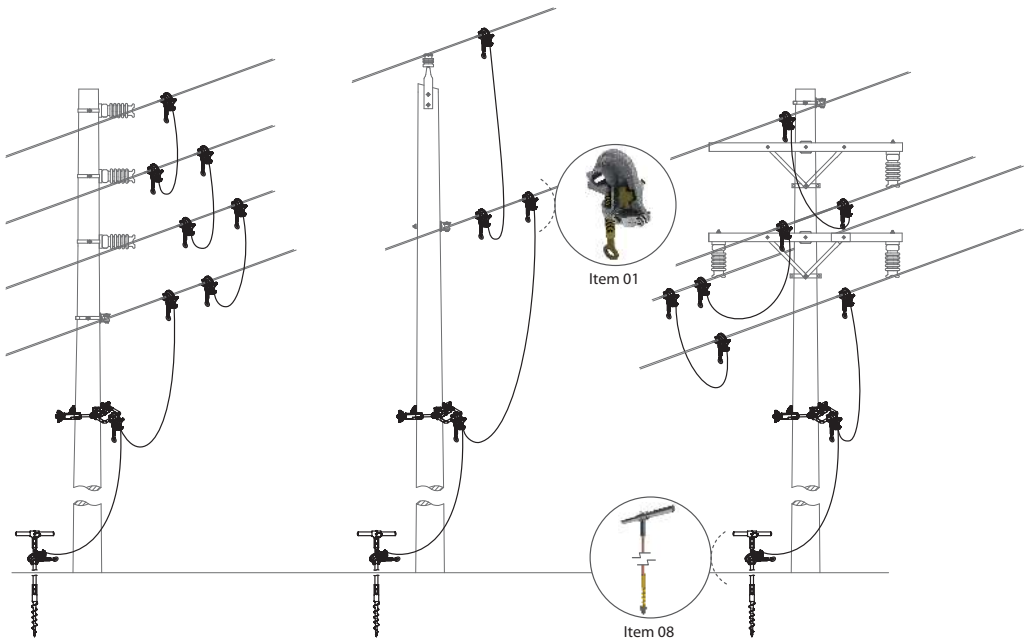

ATR17456-1

Item	Qty.	Unit.	Catalog Reference	Description
01	10	pc	RG3403	Twisting grounding clamp with eyescrew
02	03	pc	RG3626	Clamp resting support
03	01	pc	ATR03318-1	Pole-mounted cluster bar, with wheel, for grounding intermediary point
04	18	m	CTC-35	Extra-flexible copper cable, 35 mm ² cross-section, with transparent PVC insulation, being four 2 m length and one 10 m length
05	10	pc	RC600-2626	35 mm ² plain shrouded aluminum ferrule
06	10	pc	ATR17923-2	Heat shrink
07	01	pc	VMR07205-1	Tool head for grounding clamp
08	01	pc	ATR00137-1	Ø 17 mm x 1.5 m ground rod
09	01	pc	ATR16819-2	Bag for storage and transport of ground rod
10	01	pc	ATR09962-1	Bag for storage and transport of the grounding set

Temporary Grounding Set for Switchgear and Substations (MV)

Maximum short-circuit current: 60 cycles - 5 kA

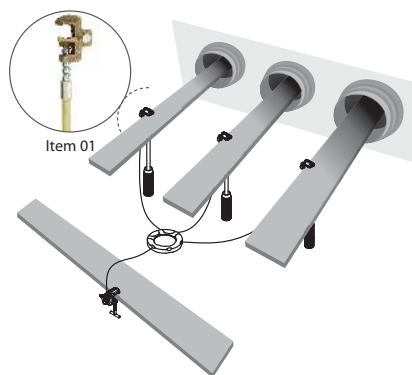

ATR17572-1

Item	Qty.	Unit.	Catalog Reference	Description
01	03	pc	ATR08947-1	Twisting grounding clamp mounted to insulated pole with handle, insulating length: 520 mm
02	07	m	CTC-25	Extra-flexible copper cable, 25 mm ² cross-section, with transparent PVC insulation, being three 2 m length and one 1 m length
03	01	pc	ATR17574-1	Thermoplastic terminal block
04	01	pc	RG3363-1	Grounding clamp with T-handle for connection to the ground point
05	07	pc	ATR26446-2	25 mm ² tin-plated copper cable lug.
06	01	pc	ATR13036-2	25 mm ² plain shrouded aluminum ferrule
07	08	pc	ATR17923	Heat shrink
08	01	pc	ATR16843-6	Bag for storage and transport of the grounding set

Temporary Grounding Set for Switchgear and Substations (MV)

Maximum short-circuit current: 60 cycles - 5 kA

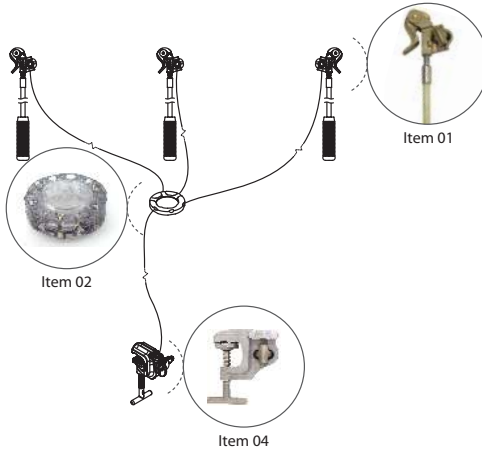

ATR20763-1

Item	Qty.	Unit.	Catalog Reference	Description
01	03	pc	ATR09033-1	Twisting grounding clamp mounted to insulated pole with handle, insulating length: 640 mm
02	07	m	CTC-25	Extra-flexible copper cable, 25 mm ² cross-section, with transparent PVC insulation, being three 2 m length and one 1 m length
03	01	pc	ATR17574-1	Thermoplastic terminal block
04	01	pc	RG3363-1	Grounding clamp with T-handle for connection to the ground point
05	07	pc	ATR26446-2	25 mm ² tin-plated copper cable lug.
06	01	pc	ATR13036-2	25 mm ² plain shrouded aluminum ferrule
07	08	pc	ATR17923	Heat shrink
08	01	pc	ATR16843-6	Bag for storage and transport of the grounding set

Temporary Grounding Set for Switchgear and Substations (MV)

Maximum short-circuit current: 60 cycles - 5 kA

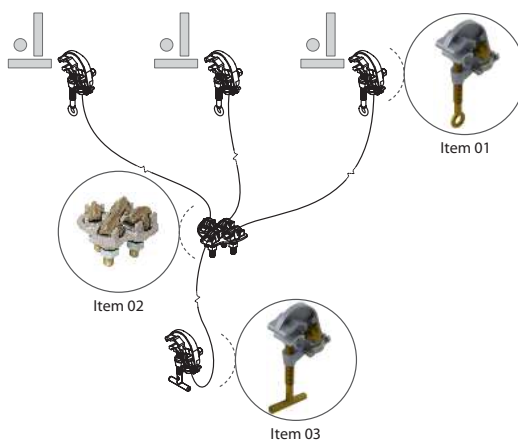

ATR12407-1

Item	Qty.	Unit.	Catalog Reference	Description
01	03	pc	ATR11627-1	Twisting grounding clamp with eyescrew for buses
02	01	pc	RG4754-1	Terminal block with 04 ground cable connectors
03	01	pc	ATR11627-2	Grounding clamp with T-handle for connection to the ground point
04	06	m	CTC-50	Extra-flexible copper cable, 50 mm ² cross-section, with transparent PVC insulation, being three 2 m length
05	06	pc	RC600-2627	50 mm ² plain shrouded aluminum ferrule
06	01	m	CTC-25	Extra-flexible copper cable, 25 mm ² cross-section, with transparent PVC insulation, being one 1 m length
07	02	pc	ATR13036-2	25 mm ² plain shrouded aluminum ferrule
08	08	pc	ATR17923	Heat shrink
09	01	pc	VMR08974-1	Switching tool head
10	01	pc	VMR02579-1	Clamp tool head
11	01	pc	VTT-1/5-1800	RITZGLAS® telescopic hot stick, 5 triangular sections. Extended length: 1.80 m; Retracted length: 0.60 m
12	01	pc	ATR29262-1	Bag for storage and transport of the grounding set

Temporary Grounding Set for Switchgear and Substations (MV)

Maximum short-circuit current: 60 cycles - 8 kA

For the specification of ball studs, indispensable to install this temporary grounding set, refer to the specific page of this product, considering the most applicable format and dimensions.

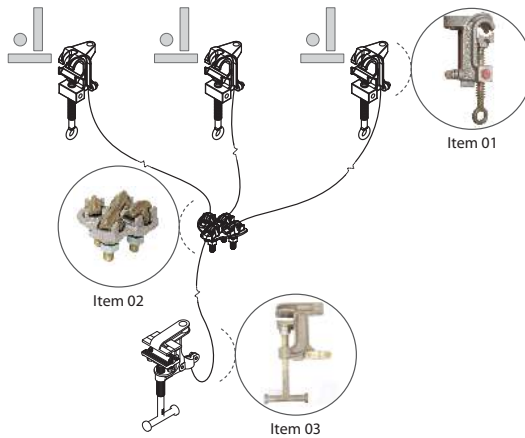

ATR17455-1

Item	Qty.	Unit.	Catalog Reference	Description
01	03	pc	RC600-2316	Twisting grounding clamp with eyescrew for ball stud or conductor mounting
02	01	pc	RG4754-1	Terminal block with 04 ground cable connectors
03	01	pc	RC600-2231	Grounding clamp with T-handle for connection to the ground point
04	4,5	m	CTC-70	Extra-flexible copper cable, 70 mm ² cross-section, with transparent PVC insulation, being three 1.5 m length
05	03	pc	RC600-2604	Plain threaded aluminum ferrule for 70 mm ² cable
06	03	pc	RC600-2628	70 mm ² plain shrouded aluminum ferrule
07	2,5	m	CTC-35	Extra-flexible copper cable, 35 mm ² cross-section, with transparent PVC insulation, being one 2.5 m length
08	01	pc	RC600-2602	Plain threaded aluminum ferrule for 35 mm ² cable
09	01	pc	RC600-2626	35 mm ² plain shrouded aluminum ferrule
10	08	pc	ATR17923	Heat shrink
11	01	pc	VMR02579-1	Clamp tool head
12	01	pc	ATR29262-1	Bag for storage and transport of the grounding set

Temporary Grounding Equipment for Vehicles (MV)

Maximum short-circuit current: 60 cycles - 5 kA

This grounding equipment model provides the discharge of the capacitance or static loads of vehicles with aerial devices or service vehicles.

For safety purposes, the use of this model is limited exclusively to the grounding of vehicles, therefore it cannot be used for different purposes.

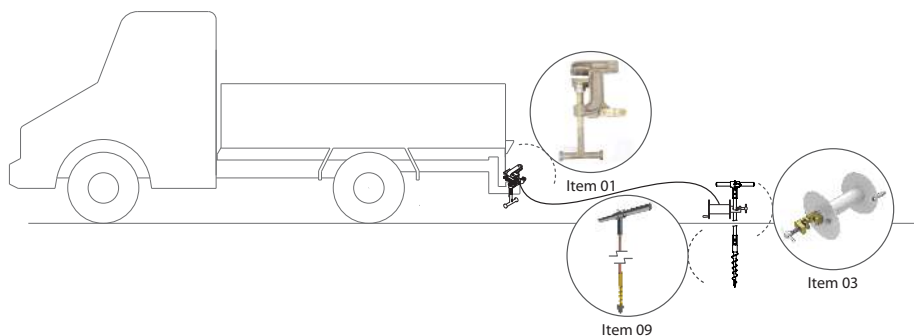

ATR17440-1

Item	Qty.	Unit.	Catalog Reference	Description
01	01	pc	RC600-2231	Grounding clamp with T-handle for connection to the ground point
02	01	pc	ATR03641-1	Mounting reel, with bronze clamp, for connection to ground rod and storage of ground cable
03	10	m	CTC-25	Extra-flexible copper cable, 25 mm ² cross-section, with transparent PVC insulation, being one 10 m length
04	01	pc	ATR17184-2	25 mm ² threaded shrouded aluminum ferrule
05	01	pc	ATR26446-2	25 mm ² tin-plated copper cable lug
06	02	pc	ATR17923	Heat shrink
07	01	pc	ATR00137-2	Ø 17 mm x 1 m ground rod
08	01	pc	ATR16819-1	Bag for storage and transport of ground rod
09	01	pc	ATR16843-7	Bag for storage and transport of the grounding set

Temporary Grounding Equipment for Vehicles with Ball Stud (MV)

Maximum short-circuit current: 60 cycles - 8 kA

This grounding equipment model provides the discharge of the capacitance or static loads of vehicles with aerial devices or service vehicles.

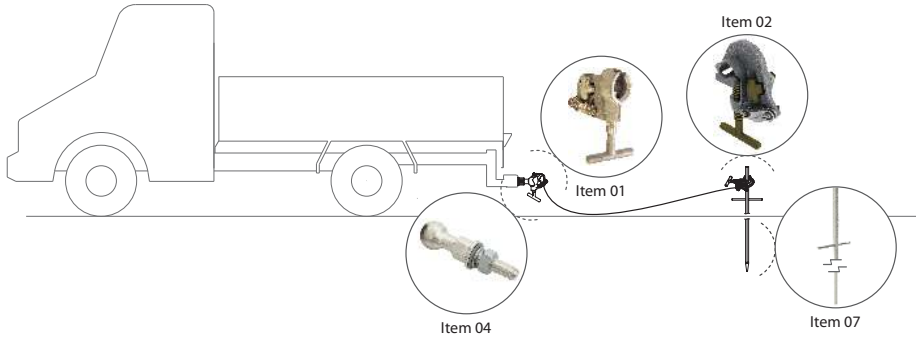

ATR17440-2

Item	Qty.	Unit.	Catalog Reference	Description
01	01	pc	RT600-2321	Ball-and-shell ground clamps T-handle for connection to the ball pin
02	01	pc	RG3403T	Grounding clamp, with T-handle for connection to the ground point
03	10	m	CTC-35	Extra-flexible copper cable, 35 mm ² cross-section, with transparent PVC insulation, being one 10 m length
04	01	m	ATR08969-2	Ball Stud pin for vehicle grounding point (M12 x 60 mm)
05	02	pc	RC600-2626	35 mm ² plain shrouded aluminum ferrule
06	02	pc	ATR17923	Heat shrink
07	01	pc	ATR00137-2	Ø 19 mm x 1 m ground rod, hexagonal section and steel handle
08	01	pc	ATR1628-1	Bag for storage and transport of ground rod
09	01	pc	ATR16843-7	Bag for storage and transport of the grounding set

HIGH VOLTAGE GROUNDING SETS

Temporary Grounding Set for Transmission Lines (HV) Wood, concrete, and metal structure

Maximum short-circuit current: 60 cycles - 25 kA

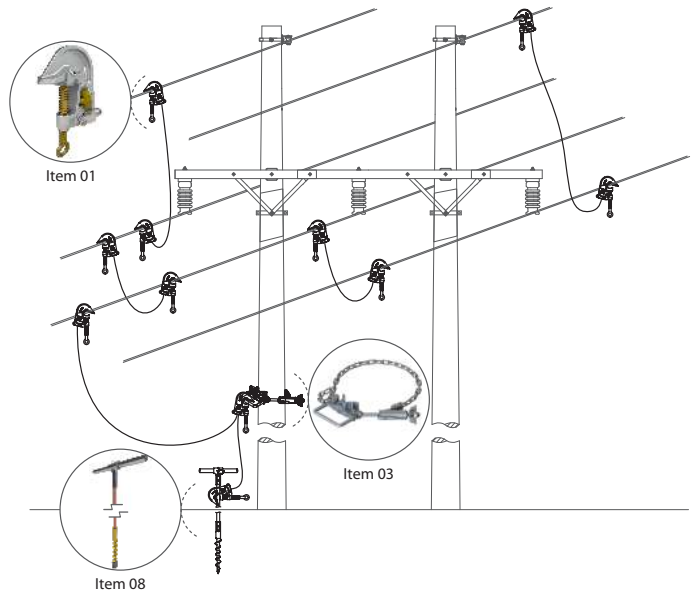

ATR17441-1

Item	Qty.	Unit.	Catalog Reference	Description
01	12	pc	RC600-0965	Twisting grounding clamp, with eyescrew and serrated jaw
02	04	pc	RG3626	Clamp resting support
03	01	pc	ATR03318-1	Pole-mounted cluster bar, with wheel, for grounding intermediary point
04	27	m	CTC-95	Extra-flexible copper cable, 95 mm ² cross-section, with transparent PVC insulation, being three 4 m length, two 3 m length, and one 9 m length
05	12	pc	RC600-2629	95 mm ² plain shrouded aluminum ferrule
06	12	pc	ATR17923-3	Heat shrink
07	01	pc	VMR07205-1	Tool head for grounding clamp
08	01	pc	ATR00137-1	Ø 17 mm x 1.5 m ground rod
09	01	pc	ATR16819-2	Bag for storage and transport of ground rod
10	02	pc	ATR09962-1	Bag for storage and transport of the grounding set

Temporary Grounding Set for Transmission Lines (HV) Metal structure

Maximum short-circuit current: 60 cycles - 25 kA

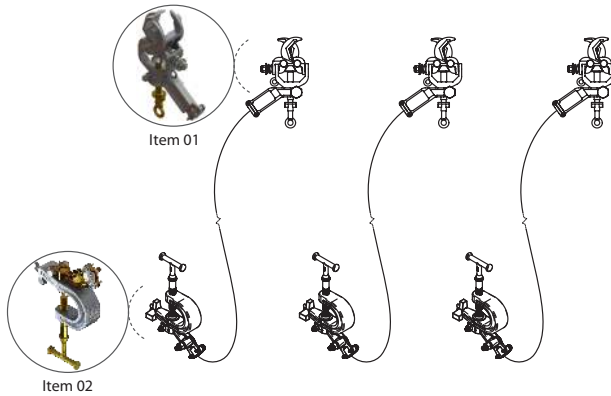

ATR17442-1

Item	Qty.	Unit.	Catalog Reference	Description
01	03	pc	RC600-1732	All angle Twisting grounding clamp with eyescrew
02	03	pc	RC600-0085	Grounding clamp with T-handle for connection to the ground point
03	24	m	CTC-95	Extra-flexible copper cable, 95 mm ² cross-section, with transparent PVC insulation, being three 8 m length
04	03	pc	RC600-2621	95 mm ² threaded shrouded aluminum ferrule
05	03	pc	RC600-2629	95 mm ² plain shrouded aluminum ferrule
06	06	pc	ATR17923-3	Heat shrink
07	03	pc	ATR14484-2	Bag for storage and transport of the grounding set

Temporary Grounding Set for Substation (HV)

Maximum short-circuit current: 60 cycles - 25 kA

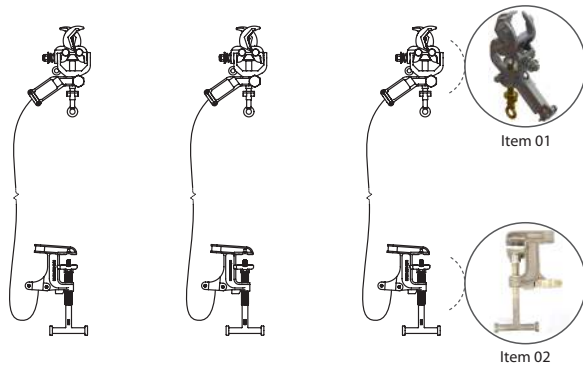

ATR17454-1

Item	Qty.	Unit.	Catalog Reference	Description
01	03	pc	RC600-1732	All angle grounding clamp with bus eyescrew
02	03	pc	RC600-2231	T-handle grounding clamp for connection to ground point (cable or angle bar)
03	30	m	CTC-95	Extra-flexible copper cable, 95 mm ² cross-section, with transparent PVC insulation, being three 10 m length
04	06	pc	RC600-2621	95 mm ² threaded shrouded aluminum ferrule
05	06	pc	ATR17923-3	Heat shrink
06	01	pc	VMR02579-1	Clamp tool head
07	01	pc	VMR00884-1	Switching tool head
08	03	pc	ATR14484-1	Bag for storage and transport of the grounding set

Temporary Grounding Set for Substation (HV)

Maximum short-circuit current: 60 cycles - 25 kA

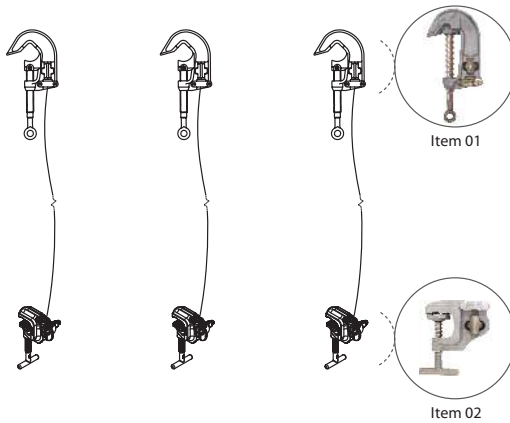

ATR17454-2

Item	Qty.	Unit.	Catalog Reference	Description
01	03	pc	RG3368	Twisting grounding clamp, with eyescrew and smooth jaw
02	03	pc	RG3363-1	Grounding clamp with T-handle for connection to the ground point
03	30	m	CTC-95	Extra-flexible copper cable, 95 mm ² cross-section, with transparent PVC insulation, being three 10 m length
04	06	pc	RC600-2629	95 mm ² plain shrouded aluminum ferrule
05	06	pc	ATR17923-3	Heat shrink
06	01	pc	VMR02579-1	Clamp tool head
07	01	pc	VMR00884-1	Switching tool head
08	03	pc	ATR14484-1	Bag for storage and transport of the grounding set

Temporary Grounding Set for Substation (HV)

Maximum short-circuit current: 60 cycles - 25 kA

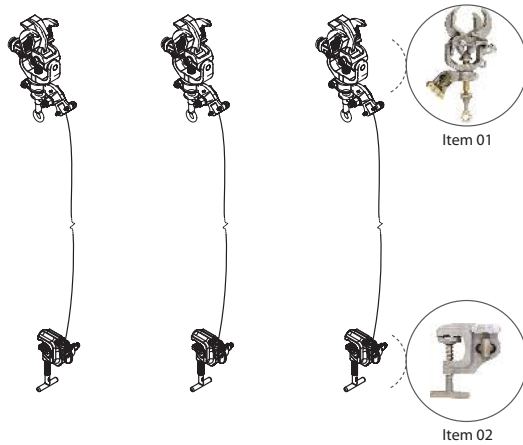

A

ATR00395-8

Item	Qty.	Unit.	Catalog Reference	Description
01	03	pc	RG4228-10SJ	All angle Twisting grounding clamp with eyescrew
02	03	pc	RG3363-1	Grounding clamp with T-handle for connection to the ground point
03	24	m	CTC-95	Extra-flexible copper cable, 95 mm ² cross-section, with transparent PVC insulation, being three 8 m length
04	06	pc	RC600-2629	95 mm ² plain shrouded aluminum ferrule
05	06	pc	ATR17923-3	Heat shrink
06	01	pc	VMR02579-1	Clamp tool head
07	01	pc	VMR00884-1	Switching tool head
08	03	pc	ATR14484-2	Bag for storage and transport of the grounding set

LIFTING AND INSTALLATION TOOL FOR SUBSTATION GROUNDING

This tool kit allows the lifting and installation of temporary grounding sets on buses in extra-high voltage substation, directly from the ground, at a height of up to 8 m.

Tip sections (ATR01875-1 and VMR/S-SP) must be coupled to separate hot sticks with lengths compatible with the substation bus height.

Section ATR01875-1 must be installed on the bus through the support hook. The VMR/S-SP section will lift the clamp and ground cable



ATR23989-1

Item	Qty.	Unit.	Catalog Reference	Description	Working Length (m)	Approx. Weight	
						kg	lb
01	01	pc	ATR01875-1	Hot stick and tip section with support hook and snatch block	1.25	3.50	7.72
02	01	pc	VMR/S-SP	Hot stick, tip section with universal head and hinged clamp	1.25	1.50	2.76
03	20	m	RM1895-2	Ø 3/8" Polypropylene Rope	-	0.05	0.11



A

ACCESSORIES

Item	Qty.	Unit.	Catalog Reference	Description	Working Length (m)	Approx. Weight	
						kg	lb
04	*	pc	VMR-I	Hot stick middle section	1.25	1.20	2.65
05	01	pc	VMR-P	Hot stick handle section	1.45	1.10	2.43
06	01	pc	**	Bag for hot stick storage	-	-	-

* Quantity defined according to bus height

** Bag defined according to the amount of sections of the Maneuver Stick

STATIC GROUNDING SET

This static grounding set is designed to reliably remove static loads on de-energized systems such as: connection terminals and conductors on transformers or generators.

To operate this tool, first connect the grounding clamp to a safe ground point.

Then, using the copper hook, install the stick at the point where the static charge must be discharged from the system.

When maintenance is complete, use the same sequential procedure adopted in the installation, but in the opposite order. That is: first remove the ground stick from the work point and then disconnect the grounding clamp.

RT600-0891

Ø 32 mm x 1,07 m RITZGLAS® stick composed of:

1 twisting duckbill clamp with T-handle (RG3363-4SJ) and
2.10 m of extra-flexible copper cable 25 mm² cross-section, with
transparent PVC insulation

Approx. Weight: 2.60 kg (5.73 lb)



GROUNDING CLAMP

Ball Studs and Ball-and-Socket Clamps for Temporary Grounding

The ball stud and ball-and-socket clamp are designed to solve countless temporary grounding situations where space or contact surfaces are limited.

In switchgears, especially with rectangular buses, where conventional ground clamps have dimensions that prevent their use, the ball-and-socket clamp stands out for its versatile design and easy operation.

This clamp is very popular in electrical installations such as:

- switchgears;
- indoor and outdoor substations;
- overhead cranes;
- hot line vehicles;
- painted transmission line structures where optimum electrical contact with conventional clamps is not obtained.

Ball studs are designed for permanent installations in buses, bus junctions, terminals or other parts of the electrical installation, establishing the points necessary for their proper temporary grounding. Therefore, purchasing them in sufficient quantities for such use is recommended.

To best suit the user needs, they are arranged with seven variations in connecting ball length and position.

Bronze alloy body and tin-plated 1020 steel thread and 3.5 daN.m installation torque.



A

BALL STUDS (STRAIGHT)

Catalog Reference	A	B	C	Approx. Weight	
				kg	lb
ATR08969-1	98	58	40	0,22	0,48
ATR08969-2	118	58	60	0,24	0,53
ATR08969-3	138	58	80	0,25	0,55
ATR08969-4	108	58	50	0,23	0,51
ATR08969-5	166	114	52	0,28	0,62
ATR08969-6	158	58	100	0,30	0,66
ATR08969-7	82	58	100	0,28	0,62

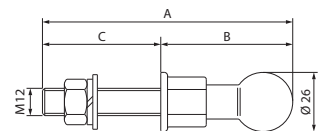

BALL STUD (L-TYPE)

Catalog Reference	A	B	C	Approx. Weight	
				kg	lb
ATR13147-1	91	50	65	0,26	0,57

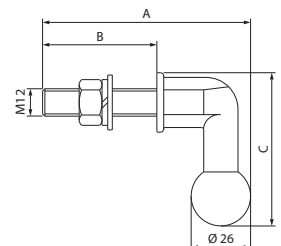

BALL-AND-SHELL GROUND CLAMPS



Catalog Reference

Electrical and Mechanical Characteristics		RC600-2300	RT600-2321
Description		Bronze alloy main body; Eyescrew; Cable connection through plain ferrule	Bronze alloy main body; T-handle; Cable connection through plain ferrule
Rated Current (A)		400	400
Short circuit current (Icc)	30 cycles (kA)	30	30
	60 cycles (kA)	23	23
Connection		Ø 26	Ø 26
Cable Ferrule (mm²)	Maximum	95	95
	Minimum	25	25
Installation Torque (daN.m)		3.0	3.0
ASTM Designation		Type I Class A Grade 5	Type III Class A Grade 5
Approx. Weight. (kg / lb)		0.76 / 1.68	0.82 / 1.81



Multi-Connection Grounding Clamp

The RC600-2316 grounding clamp can be installed on circular conductors, rectangular bars and ball studs. Its two threaded housings can be used to install ball studs in its body for the simultaneous lifting of two additional clamps for a three-phase grounding system.

Electrical and Mechanical Characteristics		Catalog Reference
		RC600-2316
Description		Aluminum main body; Eyescrew; Cable connection through plain threaded ferrule
Rated Current (A)		400
Short circuit current (I_{cc})	30 cycles (kA)	30
	60 cycles (kA)	23
Connection	Maximum	636 MCM CAA Ø 25 mm
	Minimum	8 Cu Ø 2.6 mm
Cable Ferrule (mm²)	Maximum	95
	Minimum	16
Installation Torque (daN.m)		3.0
ASTM Designation		Type I Class A Grade 5
Approx. Weight (kg / lb)		0.68 / 1.50



A

TEMPORARY GROUND CLAMPS FOR LOW AND MEDIUM VOLTAGE NETWORKS



Electrical and Mechanical Characteristics	Catalog Reference			
	RG3403	RG3403T	ATR11627-1	ATR17459-1
Description	Aluminum body; Smooth jaw; Eyescrew; Cable connection through plain ferrule	Aluminium body; Smooth jaw; T-handle; Cable connection through plain ferrule	Aluminium body; Smooth jaw; Eyescrew; Cable connection through plain ferrule	Aluminium body; Smooth jaw; Mounted to insulating tube Ø 25 mm x 1,25 m; Cable connection through plain ferrule
Rated Current (A)	300	300	-	300
Short-Circuit Current (Icc)	30 cycles (kA)	20	30	20
	60 cycles (kA)	15	23	15
Connection	Maximum	477 MCM CAA Ø 22.5 mm	477 MCM CAA Ø 22.5 mm	477 MCM CAA Ø 22.5 mm
	Minimum	6 AWG Cu 4 AWG CA Ø 4 mm	6 AWG Cu 4 AWG CA Ø 4 mm	Buses vertical 40 mm horizontal 44 mm circular 35 mm
Cable Ferrule (mm²)	Maximum	70	70	95
	Minimum	16	16	16
Installation Torque (daN.m)	3.0	3.0	3,0	3,0
ASTM Designation	Type I Class A Grade 3	Type III Class A Grade 3	Type I Class A Grade 5	Type II Class A Grade 3
Approx. Weight (kg / lb)	0.48 / 1.06	0.51 / 1.12	0.65 / 1,43	1.10 / 2.43

TEMPORARY GROUND CLAMPS FOR LOW AND MEDIUM VOLTAGE NETWORKS



Electrical and Mechanical Characteristics	Catalog Reference			
	ATR19433-1	ATR17461-1	ATR17460-1	ATR17462-1
Description	Clamp mainly designed for switchgear grounding with vertical rectangular buses. Aluminum body; Smooth jaw; Mounted to insulated pipe Ø 25 mm x 600 mm, with rubber handle; Cable connection through plain ferrule	Aluminum body; Smooth jaw; Mounted to hot stick tip section Ø 25 mm x 1.25 m, with coupling system; Cable connection through plain ferrule	Aluminum body; Smooth jaw; Mounted to telescopic hot stick, Ø 33 mm base, retracted length 1 m and extended length 1.80 m; Cable connection through plain ferrule	Aluminium body; Smooth jaw; Fixed to telescopic hot stick - Ø 33 mm base, retracted length 1.43 m and extended length 2.58 m; Cable connection through plain ferrule.
Rated Current (A)	400	300	300	300
Short-circuit Current (Icc)	30 cycles (kA)	30	20	20
	60 cycles (kA)	23	15	15
Connection	Maximum	20 mm (rectangular buses)	477 MCM CAA Ø 22.5 mm	477 MCM CAA Ø 22.5 mm
	Minimum	3 mm (rectangular buses)	6 AWG Cu 4 AWG CA Ø 4 mm	6 AWG Cu 4 AWG CA Ø 4 mm
Cable Ferrule (mm²)	Maximum	95	70	70
	Minimum	16	16	16
Installation Torque (daN.m)	3.0	3.0	3.0	3.0
ASTM Designation	Type II Class A Grade 5	Type II Class A Grade 3	Type II Class A Grade 3	Type II Class A Grade 3
Approx. Weight (kg / lb)	0.72 / 1.59	1.10 / 2.43	1.40 / 3.09	1.40 / 3.09

A

TEMPORARY GROUND CLAMPS FOR LOW AND MEDIUM VOLTAGE NETWORKS



Electrical and Mechanical Characteristics		Catalog Reference		
		ATR08947-1	ATR09033-1	ATR17348-1
Description		Bronze body; Mounted to insulated pole Ø 1/2" x 640 mm, with rubber handle; Cable connection through tin-plated copper ferrule (not included in clamp)	Bronze body; Mounted to insulated pole Ø 1/2" x 640 mm, with rubber handle; Cable connection through plain ferrule	Aluminum body; Smooth jaw; Mounted to Ø 25 mm x 300 mm insulating tube, with rubber handle; spring-loaded mounting to conductor; Cable connection through tin-plated copper ferrule (not included in clamp)
	Rated Current (A)	200	200	-
Short-circuit Current (Icc)	30 cycles (kA)	8	8	10
	60 cycles (kA)	5	5	7
Connection	Maximum	Ø 30 mm	Ø 19 mm	336,4 MCM CAA Ø 19 mm
	Minimum	Ø 4 mm	Ø 4 mm	6 AWG Cu 4 AWG CA Ø 4 mm
Cable Ferrule (mm²)	Maximum	25	25	35
	Minimum	16	16	16
Installation Torque (daN.m)		2.0	2.0	-
ASTM Designation		-	-	-
Approx. Weight (kg / lb)		0.75 / 1.65	0.65 / 1.43	0.36 / 0.79

A

TEMPORARY GROUND CLAMPS FOR LOW AND MEDIUM VOLTAGE NETWORKS



Electrical and Mechanical Characteristics	Catalog Reference			
	ATR03653-1	ATR13628-1	ATR13047-1	ATR13047-2
Description	Aluminium body; Smooth jaw; Conductor-mounted to conductor; connection to cluster bar (ATR04694-1) galvanized steel. Cable connection through copper ferrule (not included in clamp)	Aluminium body; Smooth jaw; Spring-loaded mounting connection blade spring-loaded; cluster bar (ATR14442-1) self-locking system; Cable connection through tin-plated copper ferrule (not included in clamp)	Aluminium body; Spring-loaded tap cable installation; Red plastic handle	Aluminium body; Spring-loaded tap cable installation; Black plastic handle
Rated Current (A)	-	-	-	-
Short-circuit Current (Icc)	30 cycles (kA)	10	10	10
	60 cycles (kA)	7	7	7
Connection	Maximum	336,4 MCM CAA Ø 19 mm	Ø 30 mm	Ø 12,5 mm
	Minimum	6 AWG Cu 4 AWG CA Ø 4 mm	Ø 5 mm	Ø 6,5 mm
Cable Ferrule (mm²)	Maximum	35	50	35
	Minimum	16	16	16
Installation Torque (daN.m)	-	-	-	-
ASTM Designation	-	-	Type III Class B Grade 5	Type III Class B Grade 5
Approx. Weight (kg / lb)	0.35 / 0,77	0.45 / 0.99	0.35 / 0.77	0.35 / 0.77

A

TEMPORARY GROUND CLAMPS FOR SUBSTATIONS



Electrical and Mechanical Characteristics		Catalog Reference				
		RG3368	RG3367-2	RG3369	RC600-0337*	ATRO3308-2*
Description		Aluminium body; Smooth jaw; Eyescrew; Cable connection through plain ferrule	Aluminium body; Removable and smooth jaw; Eyescrew; Cable connection through plain ferrule	Adjustable aluminum body and shoe; Smooth jaw; Eyescrew; Cable connection through plain ferrule	Adjustable aluminum body and shoe; Smooth jaw; Eyescrew; Cable connection through plain ferrule	Adjustable aluminum body and shoe; Smooth jaw; Eyescrew; Cable connection through plain ferrule
Rated Current (A)		400	400	400	400	400
Short-circuit Current (Icc)	30 cycles (kA)	30	30	30	30	30
	60 cycles (kA)	23	23	23	23	23
Connection						
Maximum		Ø 50 mm or 12 x 100 mm rectangular buses	Ø 63,5 mm	Ø 100 mm	Ø 160 mm	Ø 235 mm
Minimum		Ø 5 mm	Ø 6 mm	Ø 10 mm	Ø 90 mm	Ø 115 mm
Cable Ferrule (mm²)	Maximum	95	95	95	95	95
	Minimum	16	16	16	16	16
Installation Torque (daN.m)		3.0	3.0	3.0	3.0	3.0
ASTM Designation		Type I Class A Grade 5	Type I Class A Grade 5	Type I Class A Grade 5	Type I Class A Grade 5	Type I Class A Grade 5
Approx. Weight (kg / lb)		1.00 / 2,20	1.20 / 2.65	2.20 / 4.85	3.20 / 7.05	3.20 / 7.05

*It allows the use of two 95 mm² cables simultaneously

TEMPORARY GROUND CLAMPS FOR HIGH VOLTAGE LINES



Electrical and Mechanical Characteristics	Catalog Reference					
	RC600-1743	RG3622-1	RG3622-2	RC600-0434	RC600-0065	
Description	Aluminium body; Smooth jaw; Eyescrew; Cable connection through plain ferrule	Aluminium body; Smooth jaw; Connectors and eyescrew; Cable connection through plain ferrule	Aluminium body; Smooth jaw; Steel clamp for securing the protected cable with a perimeter from 51 to 70 mm; Connectors and eyescrew; Cable connection through plain ferrule	Aluminium body; Serrated jaw; Eyescrew; Cable connection through plain ferrule	Aluminium body; Serrated jaw; Eyescrew; Cable connection through plain ferrule	
Rated Current (A)	400	400	400	400	400	
Short-circuit Current (I_{cc})	30 cycles (kA)	30	30	30	30	
	60 cycles (I_{cc}) (kA)	23	23	23	23	
Connection	Maximum	1000 MCM Cu 1590 MCM CAA Ø 38 mm	566 MCM Cu 900 MCM CAA Ø 29 mm	566 MCM Cu 900 MCM CAA Ø 29 mm	950 MCM Cu 1510 MCM CAA Ø 38 mm	954 MCM CAA Ø 30 mm
	Minimum	6 Cu Ø 4 mm	6 Cu Ø 4 mm	6 Cu Ø 4 mm	6 Cu Ø 4 mm	6 Cu Ø 4 mm
Cable Ferrule (mm²)	Maximum	95	95	95	95	95
	Minimum	16	16	16	16	16
Installation Torque (daN.m)	3.0	3.0	3,0	3.0	3.0	
ASTM Designation	Type I Class A Grade 5	Type I Class A Grade 5	Tipo I Classe A Grau 5	Type I Class B Grade 5	Type I Class B Grade 5	
Approx. Weight (kg / lb)	0.72 / 1.59	0.72 / 1.59	0,76 / 1,68	0.92 / 2.03	0.52 / 1.15	

A

TEMPORARY GROUND CLAMPS FOR HIGH VOLTAGE LINES



Electrical and Mechanical Characteristics		Catalog Reference		
		RG4229-1SJ	ATR13159-1	RHG4229-6SJ
Description		Aluminium body; Serrated Jaw; Eyescrew; Cable connection through plain ferrule; Allows operation at continuous angles up to 75°	Aluminium body; Serrated Jaw; Eyescrew; Cable connection through plain ferrule; Locking of preset and fixed operating angles by wing nut	Aluminium body; Serrated Jaw; Cable connection Mounted to RITZGLAS® tube Ø 32 mm x 1.83 m; Cable connection through plain ferrule; Allows operation at continuous angles up to 75°
Rated Current (A)		400	400	400
Short-circuit Current (Icc)	30 cycles (kA)	30	30	30
	60 cycles (kA)	23	23	23
Connection	Maximum	954 MCM CAA Ø 30 mm	954 MCM CAA Ø 30 mm	954 MCM CAA Ø 30 mm
	Minimum	2 Cu Ø 6.5 mm	2 Cu Ø 6,5 mm	2 Cu Ø 6,5 mm
Cable Ferrule (mm²)	Maximum	95	95	95
	Minimum	16	16	16
Installation Torque (daN.m)		3.0	3.0	3.0
ASTM Designation		Type I Class B Grade 5	Type I Class B Grade 5	Type II Class B Grade 5
Approx. Weight (kg / lb)		1.15 / 2.54	1.90 / 4.19	2.00 / 4.41

A

TEMPORARY GROUND CLAMPS FOR HIGH VOLTAGE LINES



Electrical and Mechanical Characteristics	Catalog Reference			
	RC600-1732	RG4228-10SJ	ATR10777-1	RHG4228-16SJ
Description	Aluminium body; Serrated Jaw; Eyescrew; Cable connection through threaded ferrule; Allows operation at continuous angles up to 75°	Aluminum body; Serrated jaw; Eyescrew; Cable connection through plain ferrule. Allow operation at continuous angles up to 75°	Aluminum body; Serrated jaw; Eyescrew; Cable connection through plain ferrule. Locking of preset and fixed operating angles by wing nut	Aluminum body; Serrated jaw; Fixed to Ø 32 mm x 1.83 m RITZGLAS® tube; Cable connection through plain ferrule. Allow operation at continuous angles up to 75°
Rated Current (A)	400	400	400	400
Short-circuit Current (Icc)	30 cycles (kA)	30	30	30
	60 cycles (kA)	23	23	23
Connection	Maximum	Ø 73 mm	Ø 73 mm	Ø 73 mm
	Minimum	2 Cu Ø 6,5 mm	2 Cu Ø 6.5 mm	2 Cu Ø 6.5 mm
Cable Ferrule (mm²)	Maximum	95	95	95
	Minimum	16	16	16
Installation Torque (daN.m)	3.0	3,0	3,0	3,0
ASTM Designation	Type I Class B Grade 5	Type I Class B Grade 5	Type I Class B Grade 5	Type II Class B Grade 5
Approx. Weight (kg / lb)	1.50 / 3.31	1.85 / 4.08	2.60 / 5.73	3.30 / 7.28

A

TEMPORARY GROUND CLAMPS FOR HIGH VOLTAGE LINES



Electrical and Mechanical Characteristics		Catalog Reference		
		RC600-0965	RC600-2282	RC600-0386
Description		Aluminium body; Serrated Jaw; Eyescrew; Cable connection through plain ferrule.	Aluminium body; Serrated Jaw; Eyescrew; Cable connection through plain ferrule.	Aluminium body; Serrated Jaw; Fixed to Ø 32 mm x 1.83 m RITZGLAS® tube; Cable connection through plain ferrule.
Rated Current (A)		400	400	400
Short-circuit Current (I_{cc})	30 cycles (kA)	30	30	30
	60 cycles (kA)	23	23	23
Connection				
Maximum		954 MCM CAA Ø 30 mm	Ø 51 mm	Ø 51 mm
Minimum		6 Cu Ø 4 mm	6 Cu Ø 4 mm	6 Cu Ø 4 mm
Cable Ferrule (mm²)	Maximum	95	95	95
	Minimum	16	16	16
Installation Torque (daN.m)		3.0	3.0	3.0
ASTM Designation		Type I Class B Grade 5	Type I Class B Grade 5	Type II Class B Grade 5
Approx. Weight (kg / lb)		0.73 / 1.61	0.90 / 1.98	2.15 / 4.74

TEMPORARY GROUND CLAMPS FOR CONNECTION TO GROUND POINT



Electrical and Mechanical Characteristics		Catalog Reference		
		RG3363-4SJ	RG3363-1	RC600-0085
Description		Aluminium body; Serrated Jaw; T-handle; Cable connection through plain ferrule	Aluminium body; Serrated Jaw; T-handle; Cable connection through plain ferrule	Aluminium body; Bronze pad for better contact of jaw with angle bar surface; Aluminum flange (removable) for mounting to the angle bar; T-handle; Cable connection through plain ferrule
Rated Current (A)		400	400	400
Short-circuit Current (Icc)	30 cycles (kA)	30	30	30
	60 cycles (kA)	23	23	23
Connection	Maximum	38 mm (rectangular buse)	Ø 32 mm	51 a 102 mm (rectangular buse)
	Minimum	3,2 mm (rectangular buse)	Ø 5 mm	-
Cable Ferrule (mm²)	Maximum	95	95	95
	Minimum	16	16	16
Installation Torque (daN.m)		3.0	3.0	3.0
ASTM Designation		Type III Class B Grade 5	Type III Class B Grade 5	Type III Class B Grade 5
Approx. Weight (kg / lb)		0.84 / 1.85	0.79 / 1.75	1.70 / 3.75

A

TEMPORARY GROUND CLAMPS FOR CONNECTION TO GROUND POINT



Electrical and Mechanical Characteristics		Catalog Reference			
		ATR11627-2	RC600-1617	RC600-2231	RG3622-1T
Description		Aluminium body; Smooth jaw; T-handle; Cable connection through plain ferrule	Bronze body; Mobile serrated jaw; T-handle; Cable connection through plain ferrule	Bronze body; Serrated Jaw; T-handle; Cable connection through plain plain ferrule	Aluminium body; Smooth jaw; T-handle; Cable connection through plain ferrule
Rated Current (A)		400	400	400	400
Short-circuit Current (Icc)	30 cycles (kA)	30	30	30	30
	60 cycles (kA)	23	23	23	23
Connection	Maximum	Buses: vertical 40 mm horizontal 44 mm circular 35 mm	25,4 mm (rectangular buses)	38 mm (rectangular buses)	566 MCM Cu 900 MCM CAA Ø 29 mm
	Minimum	Buses: vertical 6 mm circular 6 mm	3 mm (rectangular buses)	3 mm (rectangular buses)	6 Cu Ø 4.0 mm
Cable Ferrule (mm²)	Maximum	95	95	95	95
	Minimum	16	16	16	16
Installation Torque (daN.m)		3.0	3.0	3.0	3.0
ASTM Designation		Type III Class A Grade 5	Type III Class B Grade 5	Type III Class B Grade 5	Type III Class A Grade 5
Approx. Weight (kg / lb)		0.70 / 1.54	1.20 / 2.65	0.90 / 1.98	0.76 / 1.68

Cutout Grounding Clamps

Maximum short-circuit current: 30 cycles - 20 kA

Specially designed clamp for temporary grounding of the cutout in medium voltage networks by installing it on the bottom base of the cutout after removal of the cartridge.

Cables can be attached directly to this clamp (either to the conventional grounding clamp or to the "L" or "T" brackets). Another great use for this clamp is that it prevents the cutout from being accidentally switched while it is in the mains.

The body and studs "L" and "T" are made of aluminum alloy with a bronze alloy eyescrew.

Catalog Reference	Description	Approx. Weight	
		kg	lb
RC600-0861	Cutout grounding clamps with T-stud	0.73	1.61
RC600-0862	Cutout grounding clamps with L-stud	0.67	1.48



RC600-0861



RC600-0862



A

Grounding Clamp for Hookstick Switch

Maximum short-circuit current: 30 cycles - 20 kA

ATR01726-3

This clamp has been specially designed for temporary grounding of hookstick switches in medium voltage systems. It has body and jaws in cast aluminum alloy and eye screw of maneuver in cast bronze alloy, in which it makes possible the installation through means of stick or maneuvering rod. It has "T" support in cast aluminum alloy, where another grounding clamps can be connected, for connect to the ground point.

Approx. Weight: 1.20 kg (2.65 lb)



ATR01726-3



COPPER CABLES FOR GROUNDING



Extra flexible electrolytic copper cable with 750 V and translucent PVC insulated protection, allowing inspections of the perfect condition of the copper filaments. It is suitable for use on temporary and terminal grounding.

For easy size identification and classification, the application and year of manufacture are engraved on the entire length of the cable.

COPPER CABLES FOR GROUNDING EQUIPMENT

Catalog Reference	Cross Section (mm ²)	AWG Size (mm ²)	Icc Capacity (symmetric kA) 60 cycles (1 Seg.)	Rated Current (A)	Maximum Electrical Resistance 20° C (ohms / km)	Wire Formation	∅ Wire Maximum (mm)	∅ External (mm)	Minimum Insulation Thickness (mm)	Approx. Weight	
										kg/m	lb/m
CTC-25	25	-	5.0	150	0.795	19 x 42	0.26	11.52	1.8	0.300	0.661
CTC-35	35	2 (33.63)	8.0	200	0.565	37 x 30	0.31	12.90	2.0	0.400	0.882
CTC-50	50	1/0 (53.48)	10.0	250	0.386	19 x 52	0.31	14.53	2.0	0.545	1.202
CTC-70	70	2/0 (67.42)	15.0	300	0.272	61 x 23	0.31	17.00	2.2	0.765	1.687
CTC-95	95	4/0 (107.20)	25.0	400	0.210	51 x 31	0.31	19.03	2.2	1.000	2.205

GROUND CABLE FERRULE

They are crimped to the ends of the grounding cables to form a good electrical and mechanical connection between grounding cables and clamps. They are also made of aluminum or copper, with internal diameters according to the rated cable cross-section. Fastening system options are clamp, threaded, or plain.

A heat shrink overlaps connection points between the cable and the ferrule, preventing moisture penetration and minimizing chances cable breaking due to handling.

Both also have two crimping types:

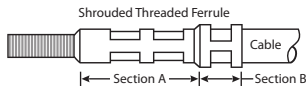
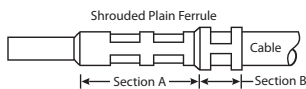

Shrouded ferrule

It has a crimp area, over the PVC and cable.

Unshrouded ferrule

Only the conductor is crimped.

ALUMINUM FERRULE

Catalog Reference	For Cross-Section Copper Cables (mm ²)	Description	Approx. Weight	
			kg	lb
ATR17179-2	25	Unshrouded plain	0.07	0.15
RC600-2610	35	Unshrouded plain	0.07	0.15
RC600-2611	50	Unshrouded plain	0.07	0.15
RC600-2612	70	Unshrouded plain	0.08	0.18
RC600-2613	95	Unshrouded plain	0.08	0.18
ATR17185-2	25	Unshrouded threaded	0.06	0.06
RC600-2602	35	Unshrouded threaded	0.06	0.06
RC600-2603	50	Unshrouded threaded	0.06	0.06
RC600-2604	70	Unshrouded threaded	0.07	0.15
RC600-2605	95	Unshrouded threaded	0.08	0.18
ATR13036-2	25	Shrouded plain	0.06	0.13
RC600-2626	35	Shrouded plain	0.06	0.13
RC600-2627	50	Shrouded plain	0.06	0.13
RC600-2628	70	Shrouded plain	0.07	0.15
RC600-2629	95	Shrouded plain	0.07	0.15
ATR17184-2	25	Shrouded threaded	0.07	0.15
RC600-2618	35	Shrouded threaded	0.07	0.15
RC600-2619	50	Shrouded threaded	0.07	0.15
RC600-2620	70	Shrouded threaded	0.08	0.18
RC600-2621	95	Shrouded threaded	0.08	0.18



Unshrouded plain aluminium ferrule



Unshrouded threaded aluminium ferrule



Shrouded plain aluminium ferrule



Shrouded threaded aluminium ferrule

A

COPPER FERRULE

Catalog Reference	For Cross-Section Copper Cables (mm ²)	Description	Approx. Weight	
			kg	lb
ATR17179-8	25	Unshrouded plain	0.10	0.22
RC600-2614	35	Unshrouded plain	0.10	0.22
RC600-2615	50	Unshrouded plain	0.20	0.44
RC600-2616	70	Unshrouded plain	0.20	0.44
RC600-2617	95	Unshrouded plain	0.23	0.51
ATR17185-8	25	Unshrouded threaded	0.12	0.26
RC600-2606	35	Unshrouded threaded	0.12	0.26
RC600-2607	50	Unshrouded threaded	0.13	0.29
RC600-2608	70	Unshrouded threaded	0.15	0.33
RC600-2609	95	Unshrouded threaded	0.16	0.35
ATR13036-8	25	Shrouded plain	0.18	0.40
RC600-2630	35	Shrouded plain	0.18	0.40
RC600-2631	50	Shrouded plain	0.20	0.44
RC600-2632	70	Shrouded plain	0.23	0.51
RC600-2633	95	Shrouded plain	0.23	0.51
ATR17184-8	25	Shrouded threaded	0.20	0.44
RC600-2622	35	Shrouded threaded	0.20	0.44
RC600-2623	50	Shrouded threaded	0.23	0.51
RC600-2624	70	Shrouded threaded	0.23	0.51
RC600-2625	95	Shrouded threaded	0.23	0.51



Unshrouded plain copper ferrule



Unshrouded threaded copper ferrule



Shrouded plain copper ferrule



Shrouded threaded copper ferrule

TIN-PLATED COPPER FERRULE

Catalog Reference	For Cross-Section Copper Cables (mm ²)	Description	Approx. Weight	
			kg	lb
ATR26446-2	25	Tin-plated copper	0.02	0.04
ATR26446-3	35	Tin-plated copper	0.02	0.04
ATR26446-4	50	Tin-plated copper	0.03	0.07
ATR26446-5	70	Tin-plated copper	0.04	0.09
ATR26446-6	95	Tin-plated copper	0.06	0.13



These ferrules are designed to be connected to clamps through screws.

GROUNDING CLUSTER

Grounding cluster bars are designed to simultaneously raise grounding clamps to conductors in a safe sequence of operations.

They are commonly used in conventional medium voltage overhead lines interventions.

ATR04694-1



Made of aluminum and galvanized steel rod and universal bronze fitting, this cluster bar is suitable for installation and removal of spring-loaded grounding clamps (ATR03653-1).

Approx. Weight : 0.53 kg (1.17 lb)

ATR14442-1



Made of aluminum and galvanized steel rod, this model is suitable for lifting, installing, and removing ATR13628-1 spring-loaded clamps.

Approx. Weight: 0.68 kg (1.50 lb)

ATR04116-1



Made of aluminum with bronze connectors, it is suitable for medium size clamps.

Approx. Weight: 1.0 kg (2.20 lb)

ATR18867-1



Made of aluminum with bronze connectors, it is suitable for small size clamps.

Approx. Weight: 0.40 kg (0.88 lb)

A

SADDLE-TYPE CLUSTER

The five saddle-type cluster bars models allow the formation of an intermediate ground point in the work structure.

ATR03318-1



Made of aluminum, it has a belt chain and tightening wheel for perfect electrical contact with the pole.
Approx. weight 3.17 kg (6.99 lb)

RC600-0152



Made with aluminum plate and copper shaft. Can be connected by plain terminals to grounding cables from 16 to 95 mm².
Approx. weight 4.30 kg (9.48 lb)

ATR14477-1



Made with pole-mounting chain device, nylon rod and wing nut for cable connection.
Approx. weight: 0.43 kg (0.95 lb)

AUXILIARY EQUIPMENT

Clamp Resting Supports

Designed for simultaneous lifting of the clamps to be installed.

The resting supports are suitable for any type of clamps, being the model RC600-0080 specific for attachment of clamps with threaded ferrules.



RG3625



RG3626



RC600-0080

CLAMP RESTING SUPPORTS

Catalog Reference	Material	Approx. Weight	
		kg	lb
RG3625	Aluminium	0.13	0.29
RG3626	Aluminium	0.06	0.13
RC600-0080	Bronze	0.15	0.33

Metallic Reel

Metallic reel, with bronze clamp mounting, to connect the cable to the grounding rod and can store the cable during transport.

Electrical and Mechanical Characteristics		Catalog Reference
		ATR03641-1
Rated Current (A)		200
Short-circuit Current (Icc)	30 cycles (kA)	8
	60 cycles (kA)	5
Connection	Maximum	Ø 19 mm
	Minimum	Ø 2 mm
Cable Ferrule (mm ²)	Maximum	25
	Minimum	16
Installation Torque (daN.m)		2.0
ASTM Designation		-
Approx. Weight (kg / lb)		1.85 / 4.07



ATR03641-1

Terminal Block

The blocks allow the connection between the phase clamps and the earth clamp.

RG4754-1



An aluminum block, with 04 connectors for grounding cables from 25 to 95 mm².

Approx. weight 0.51 kg (1.12 lb)

ATR17574-1



Thermoplastic terminal block for up to 5 tin-plated copper ferrules for grounding cables up to 50 mm².

Approx. weight 0.32 kg (0.71 lb)

Special Connector and Adapter

RC600-1584

Threaded connector for mounting the threaded cable ferrule to the grounding clamp in special situations where the clamp has a threadless connection.

Approx. weight 0.19 kg (0.42 lb)



RC600-1584

Conector Duplo

ATR26555-1

The Double Connector is designed for the mounting of two grounding cables in a single clamp. A plain terminal must be fixed to one cable and a threaded terminal to the other cable.

Approx. weight 0.11 kg (0.24 lb)



ATR26555-1

Grounding Rod

Copper plated steel Grounding rod, threaded tip support and cast copper alloy casted with rubber protection, steel handle removable for easy packing, transportation and storage.

Catalog Reference	Dimensions	Storage Bag* (optional)	Approx. Weight	
			kg	lb
ATR00137-1	Ø 17 mm x 1.50 m	ATR16819-2	3.65	8.04
ATR00137-2	Ø 17 mm x 1.00 m	ATR16819-1	2.60	5.73
ATR00137-3	Ø 17 mm x 1.80 m	ATR16819-3	4.50	9.92

* All bags has reinforced edges. Ideal for storage and transport of screw ground rod.



ATR00137

Grounding rod hot-dip galvanized steel, hexagonal section and steel handle.

Catalog Reference	Dimensions	Storage Bag* (optional)	Approx. Weight	
			kg	lb
ATR08814-1	Ø 19 mm x 1.00 m	ATR16828-1	2.40	5.29
ATR08814-2	Ø 19 mm x 1.20 m	ATR16828-2	3.00	6.61
ATR08814-3	Ø 19 mm x 1.50 m	ATR16828-3	3.60	7.94
ATR08814-4	Ø 19 mm x 0.85 m	ATR16828-4	2.00	4.41

* All bags has reinforced edges. Ideal for storage and transport of screw ground rod.



ATR08814

Grounding rod with threaded tip and copper alloy casted with rubber protection, steel handle removable for easy packing, transportation and storage.

Catalog Reference	Dimensions	Storage Bag* (optional)	Approx. Weight	
			kg	lb
ATR03402-1	Ø 20 mm x 0.80 m	ATR21170-1	5.30	11.68

* All bags has reinforced edges. Ideal for storage and transport of screw ground rod.



ATR03402-1

HOT LINE CLAMP

Nominal current capacity: 230 A

FLV19192-1

Mainly used for connecting transformers to medium voltage networks, with or without the use of a stirrup connector.



FLV19192-1



DIFFERENTIALS

- Body and jaw made of cast aluminum and only connector and eyescrew are made of cast bronze, significantly reducing its weight;
- Connection for shotgun to avoid any movement while lifting and installation;
- Spring-loaded jaw for easy clamping to the conductor and safe stick positioning, clamp twisting and mounting;
- Connector output angle for lead wire for easy mounting.

GROUP B



Access our site.



HAND STICKS, HOT STICKS AND UNIVERSAL TOOLS



Grip-all Clampsticks	077	Tool Rack and Crossarm Tool Hanger.....	095
Telescopic Hot Sticks	080	Universal Tools	096
Sectional Hot Sticks	084	Lever Type Wire Cutters.....	105
Operational Heads	086	Tree Trimmers.....	107
Universal Poles	088	Universal Tool Head For Cutting Wires.....	107
Tie Sticks.....	089	Kite Buster Tool.....	108
Flexible Insulated Wrenches	090	Conductor Stripper.....	109
Insulating Grip Pole	091	Pole Handling Tools	109
Wire-holding Stick.....	092	Auxiliary Stick for Positioning on Utility Poles Installation	110
All-angle Cog Wrench	093	Rescue Hook.....	111
Volt-ammeter Stick	094	Measuring Stick And Extension	112

GROUP B

HAND STICKS, HOT STICKS AND UNIVERSAL TOOLS



GRIP-ALL CLAMPSTICKS

B

It has a mechanism comprising a folding and retractable hook at its end, operated by an adjustable handle in its grip region in three basic working positions through a rack and two safety locks, making it a practical multi-purpose tool.

Among its various applications, we highlight mounting and removal work of hot line clamps, temporary grounding assemblies, hot line protective covers, measuring instruments and others.

OPEN

Position to hook the eye of the grounding clamp or other part to be handled.



CLOSED

In this position, the hook wraps around the grounding clamp eye, holding it securely, but still pivoting, allowing a twisting movement, including at angles.



RETRACTED

The hook retracted inside the head keeps the grounding clamp rigidly attached to the pole for its mounting and removal.



GRIP-ALL CLAMPSTICKS

Catalog Reference	Ø (mm)	Dimensions			Maximum Use Voltage (kV)	Storage (optional)	Approx. Weight	
		Insulating Length (m)	Total Length (m)				kg	lb
LIGHT MODEL	25	FLV08958-1	0.54	1.43	15	FLV18339-1	2.15	4.74
		FLV08958-2	0.74	2.04	35	FLV18339-2	2.50	5.51
		FLV08958-3	1.30	2.65	138	FLV18339-3	2.85	6.28
		FLV08958-4	1.86	3.26	230	FLV18339-4	3.20	7.05
		FLV08958-5	2.42	3.87	345	FLV18339-5	3.55	7.83
NORMAL MODEL	32	RC403-0291	0.54	1.43	15	FLV18339-1	2.40	5.29
		RC403-0292	0.74	2.04	35	FLV18339-2	2.70	5.95
		RC403-0293	1.30	2.65	138	FLV18339-3	3.20	7.05
		RC403-0294	1.86	3.26	230	FLV18339-4	3.60	7.94
		RC403-0295	2.42	3.87	345	FLV18339-5	4.10	9.04



GRIP-ALL CLAMPSTICKS - FOLDING MODEL

Catalog Reference	Ø (mm)	Dimensões			Max Use Voltage (kV)	Storage (optional)	Approx. Weight	
		Insulating Length (m)	Folded Length (m)	Extended Length (m)			kg	lb
RC403-0296	32	0.95	1.01	2.00	36	FLV18339-6	3.00	6.60
RC403-0297		1.37	1.32	2.59	138	FLV18339-7	3.60	7.90
RC403-0298		1.98	1.60	3.20	230	FLV18339-8	4.00	4.80
RC403-0299		2.59	1.93	3.81	345	FLV18339-9	4.40	9.70
RC403-0342		3.20	2.23	4.42	450	FLV18339-10	4.80	10.50
RC403-0343		3.81	2.54	5.03	500	FLV18339-11	5.10	11.20



The applicability of the grip-all clampstick can be further enhanced by purchasing a RM1867 adapter.

Rated working capacity (traction) is 133 daN (293 lb) for all models.

The RE403-2543P collar can be used on any grip-all clampstick, especially longer ones, which require a great deal of effort from the electrician to hold it when in use, especially in the horizontal position.

The collar is attached to the clampstick by adjusting the halves of the ring and tightening it by its screws. This ring has a central housing for the pole and its control rod, thus not interfering with its operating mechanism.

To maintain a safe insulation distance in hot line work, it should be used in series with a rope and a tourniquet draw pole of appropriate insulating length.



RE403-2543P



RM1867



RE403-2543P

ACCESSORY

Catalog Reference	Description	Approx. Weight	
		kg	lb
RM1867	Universal adapter	0.14	0.31
RE403-2543P	Auxiliary collar with hoisting ring	0.42	0.93

Grip-all Clampstick Extension

Extensions are easily adaptable to the head of any RITZGLAS® clampstick model and are designed to extend length without compromising performance.

Catalog Reference	Ø (mm)	Overall Length (m)	Approx. Weight	
			kg	lb
RC403-0378	32	1.83	2.60	5.73
RC403-0377		1.22	1.22	2.00



TELESCOPIC HOT STICKS



The purpose of the telescopic hot stick (triangular cross-section RITZGLAS®) is to ensure the safety clearance and isolation required for interventions in electrical installations.

VTT allows the coupling of tool heads and a series of universal tools for the most diverse applications, maintaining the required safety clearance and isolation. Its use does not require stairs or platforms. Tasks can be performed directly from the ground.

Made of high-visibility color, resin-impregnated fiberglass tube and tip section, made of RITZGLAS®, it has a foam core and ensures total insulation, complying with ASTM F1826. It has a universal aluminum head tool, thumbscrew, reinforced plastic coupling pins, closure, and rubber terminal.

VTT Light Model

Used in situations that requires less mechanical effort such as replace cutouts tubes and disconnect switches; voltage detector handling and light bulb replacement.

Either section may be supplied separately if replacement is required.

LIGHT MODEL

Catalog Reference	Qty. of Section	Retracted Length (m)	Extended Length (m)	Ø Base Section (mm)	Bag Reference (optional)	Approx. Weight	
						kg	lb
VTT-1/5-1800	5	0,62	1.80	45	SLT-1/5-1800	1.28	2.83
VTT-1/2	2	1.43	2.58	33	SLT-2/3	1.30	2.87
VTT-1/3	3	1.48	3.82	37	SLT-2/3	1.90	4.19
VTT-1/4	4	1.53	5.10	41	SLT-4/5	2.50	5.51
VTT-1/5	5	1.59	6.43	45	SLT-4/5	3.20	7.05
VTT-1/6	6	1.63	7.77	49	SLT-6/7	3.90	8.60
VTT-1/7	7	1.68	9.16	52	SLT-6/7	4.70	10.36
VTT-1/8	8	1.74	10.59	56	SLT-8/9	5.70	12.57
VTT-1/9	9	1.77	12.04	61	SLT-8/9	6.90	15.21

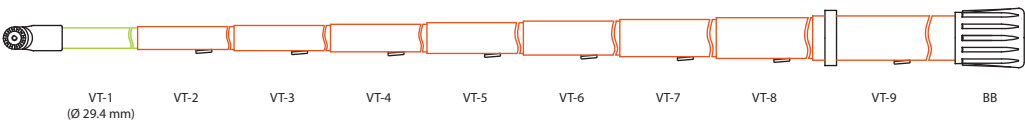

Height Measuring Hot Stick

VTT-1/2 to VTT-1/9 can be supplied with metric graduations, making the telescopic hot stick a tool for vertical spacing measurements.

There are numerical marks every 10 cm and intermediate marks every centimeter. To perform a reading, the stick must be supported on the ground in the vertical position and as the sections are handled, the operator has access to the reading within visual range.

To purchase this tool simply include the suffix "M" in the telescopic stick model reference code.

E.g.: VTT-1/7M (9.180 ± 0.01 m length).

The VTT stick modular system is designed so that only the required number of sections for each service is used. By pressing the locking buttons, the unnecessary lower sections are released and removed, making the telescopic stick lighter and more comfortable for tasks.

Either section may be supplied separately if replacement is required.





VTT 3HD Heavy-Duty Model

The VTT-3HD Heavy-Duty model triangular cross-section telescopic hot stick provides greater mechanical strength with considerable reduced flexibility, for tasks that require increased stress.

The VTT may have its third section (VT-3) replaced by a VT-3HD tip section, turning the VTT assembly into a more mechanically resistant VTT-3HD.

Either section may be supplied separately if replacement is required.

HEAVY-DUTY MODEL

Catalog Reference	Qty. of Section	Retracted Length (m)	Extended Length (m)	Ø Base Section (mm)	Bag Reference (optional)	Approx. Weight	
						kg	lb
VTT-3HD/4	2	1.51	2.74	41	SLT-4/5	1.80	3.97
VTT-3HD/5	3	1.58	4.07	45	SLT-4/5	2.50	5.51
VTT-3HD/6	4	1.61	5.43	49	SLT-6/7	3.20	7.05
VTT-3HD/7	5	1.66	6.81	52	SLT-6/7	4.00	8.82
VTT-3HD/8	6	1.73	8.24	56	SLT-8/9	5.00	11.02
VTT-3HD/9	7	1.76	9.71	61	SLT-8/9	6.20	13.67

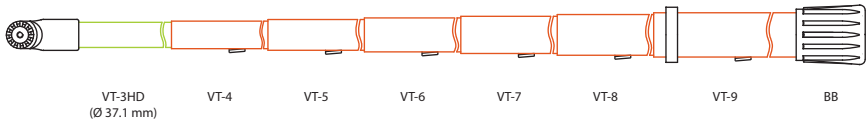

VTT Reinforced Model with Sleeve

This triangular cross-section telescopic hot stick model has sleeves which increases mechanical strength, with considerable reduced flexibility for situations where increased mechanical stress is required.

Either section may be supplied separately if replacement is required.



Reinforcement rings for the pins's windows

REINFORCED MODEL WITH SLEEVE

Catalog Reference	Qty. of Section	Retracted Length (m)	Extended Length (m)	Ø Base Section (mm)	Bag Reference (optional)	Approx. Weight	
						kg	lb
VTT 29537-1/2	2	1.38	2.39	33	SLT-2/3	1.30	2.90
VTT 29537-1/3	3	1.50	3.55	37	SLT-4/5	1.80	4.00
VTT 29537-1/4	4	1.62	4.76	41	SLT-6/7	2.50	5.50
VTT 29537-1/5	5	1.76	6.00	45	SLT-8/9	3.20	7.10
VTT 29537-1/6	6	1.88	7.30	49	VTT17182-G05	4.00	8.90
VTT 29537-1/7	7	2.00	8.63	52	VTT17182-G06	4.90	10.90
VTT 29537-1/8	8	2.11	10.00	56	VTT17182-G07	6.10	13.50

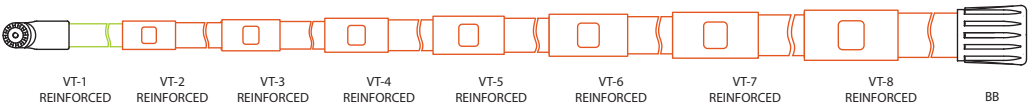

VTT for Motorcycle Model

Designed for packaging and transport in a motorcycle trunk, in which divided into three sections of 3 elements each, do not exceed the length of 1200mm.

VTT FOR MOTORCYCLE MODEL

Catalog Reference	Qty. of Section	Retracted Length (m)	Extended Length (m)	Ø Base Section (mm)	Approx. Weight	
					kg	lb
VTT 28790-1/9	9	1.44	8.94	60	5.50	12.10

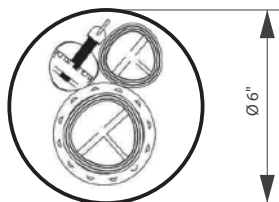

SECTIONAL HOT STICKS

The sectional hot stick is maintain the necessary insulation and safe distance for overhead line operations, by using universal tools, specially developed for the most diverse applications, such as:



- Knife-switches operation;
- Fuse-switches operation;
- Fuse cartridge removal and installation;
- Voltage testers handling;
- Installation and removal of temporary grounding equipment and live line clamps;
- Life wire installation;
- Pruning trees;
- Cleaning of Networks;
- Light bulb replacement, etc.

Manufactured with RITZGLAS® tubes, fiberglass insulating tube, impregnated with epoxy resin. In order to facilitate its handling, storage and transportation more practical, the Sectional Hot Stick is composed of standardized elements, which are handle section, middle section(s) and top section, interchangeable and attached with quick spring-action locking pins, reinforced by metallic rings, beyond universal head in fused bronze, steel wing screw, pole sleeve reinforcement nylon and rubber base terminal.

The total length suitable for each working voltage class and/or height of work is obtained from the amount of its elements. There are two versions depending on their diameter/weight, being them, the standard model and the light model.

SECTIONAL HOT STICKS

Catalog Reference	Section	Ø (mm)	Lenght (m)		Approx. Weight	
			Work	Total	kg	lb
VMR-S	Tip	32	1.25	1.45	1.15	2.54
VMR/L-S	Light tip	25	1.25	1.45	0.85	1.87
VMR-I	Middle	38	1.25	1.45	1.20	2.65
VMR/L-I	Light middle	32	1.25	1.45	0.80	1.76
VMR-P	Handle	38	1.45	1.45	1.10	2.43
VMR/L-P	Light handle	32	1.45	1.45	0.70	1.54



VMR-S



VMR-I



VMR-P

SECTIONAL HOT STICKS

Catalog Reference	Handle	Ø	Number of Sections				Total	Max. Length (m)	Bag Reference (optional)	Approx. Weight	
			Middle	Ø	Tip	Ø				kg	lb
VMR-15	1	32	-	-	-	-	1	1.25	VMR16824-1	0.95	2.09
VMR-15/L	1	25	-	-	-	-	1	1.25	VMR16824-1	0.75	1.65
VMR-30	1	38	-	-	1	32	2	2.70	VMR16824-2	2.25	4.96
VMR-30/L	1	32	-	-	1	25	2	2.70	VMR16824-12	1.55	3.42
VMR-45	1	38	1	38	1	32	3	3.95	VMR10484-3	3.45	7.61
VMR-45/L	1	32	1	32	1	25	3	3.95	VMR10484-3	2.35	5.18
VMR-70	1	38	2	38	1	32	4	5.20	VMR16825-1	4.65	10.25
VMR-70/L	1	32	2	32	1	25	4	5.20	VMR16825-1	3.15	6.94
VMR-90	1	38	3	38	1	32	5	6.45	VMR16826-1	5.85	12.90
VMR-90/L	1	32	3	32	1	25	5	6.45	VMR16826-1	3.95	8.71

For greater operational safety, observe the minimum distances according to the OSHA table.

OPERATIONAL HEADS

Grounding Clamp Heads

The grounding clamp heads are made of aluminum and have a universal locking system, adaptable to the hot sticks. They are used for grounding clamp operation through eyescrew locking.

VMR02579-1



Locking system via adjustable pressure half-ball.
Approx. Weight: 0.19 kg (0.42 lb)

VMR07205-1



It has a galvanized steel rod for alignment and spring-loaded automatic clamping.
Approx. Weight: 0.25 kg (0.55 lb)

RM4455-29B



B Locking and release of the clamp is performed through a rotation of 180° twisting operation. It allows the articulation of the clamp, enabling the operation at different angles.
Approx. Weight: 0.31 kg (0.68 lb)

Head with Fall-Protection System

These heads are used for switching, installation, and removal of fuse holder cartridges without risks of accidental drops.

It has an automatic safety locking device (fall arrest) to ensure the safety of the electrician.

FLV11554-1



Hot-dip galvanized steel main body, safety lock and universal bronze alloy head.
Approx. Weight: 0.34 kg (0.75 lb)

FLV13872-1



Main body in coated steel, with plastic and safety lock. Bronze alloy universal head.
Approx. Weight: 0.30 kg (0.66 lb)

Heads for Operation of Fuse Switches

Universal coupling, standard heads, adaptable to hot sticks.

VMR16483-1



Aluminum tilted head with circuit-breaker switching shaft and groove for fuse holder cartridge tongue.
Approx. Weight: 0.25 kg (0.55 lb)

VMR00884-1



Stainless steel head with circuit-breaker switching shaft and groove for fuse holder cartridge tongue.
Approx. Weight: 0.29 kg (0.64 lb)

VMR08974-1



Bronze head with shaft for circuit breaker switching.
Approx. Weight: 0.11 kg (0.24 lb)

VMR01479-2



Copper alloy key disconnect head.
Approx. Weight: 0.18 kg (0.40 lb)

VMR11560-1



Stainless steel key disconnect head.
Approx. Weight: 0.13 kg (0.29 lb)

VMR03414-1



Tool made of steel with anticorrosive surface treatment of electrolytic galvanization, and with universal head made of cast bronze alloy. It is intended for the switching of keys by cutting circuit like knife keys and fuse keys through its maneuvering rod. The shape of its body is designed to fit into fuse holder cartridge tongues, sailfish and ICC anchor hook. It can also be used for lifeline.
Approx. Weight: 0.28 kg (0.62 lb)

Big Eye Pin for HL Instalation

FLV31217-1

Device used to anchor the lifeline in DT concrete and wooden posts already drilled. The device is attached to the universal head (heads for operation of switches) installed on the pole or telescopic hot stick and inserted into one of the holes in the pole, according to the height chosen for anchoring the lifeline.

Approx. Weight: 0.94 kg (2.07 lb)

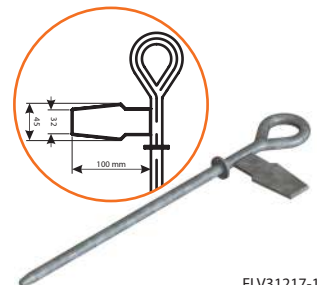

FLV31217-1

UNIVERSAL POLES

It consists of a universal head (toothed) for easy, fast, and safe coupling of all universal tools, mounted with a thumbscrew, which comes with the stick. This enables the electrician to place the universal tool at angles of up to 90° to the pole.



Depending on the configuration of the universal tool, a universal adapter (RM4455-84) can be installed between the pole and the tool to obtain any desired angle.



Rigid splice

The universal stick, with attached rubber drip skirt, is designed for emergency wet operations (rubber drip skirts provide additional flow distance and change the water course to prevent it from dripping down the stick).

The rigid splice provides a convenient way of transport while maintaining proper lengths for the tasks to be performed.

All models have a rest strap (RH1760-5).

Please note that the bags for storage and carrying all universal sticks can be purchased separately.



UNIVERSAL POLES

Catalog Reference	Description	Dimensions		Storage (optional)	Approx. Weight	
		Ø (mm)	Insulating Length (m)		kg	lb
RH1760	With 1 head at one end, rubber base at the other and lace hook	32	2.40	FLV18339-3	1.75	3.86
RH1760-1	With 1 head on one end and rubber base on the other	32	1.79	FLV18339-2	1.30	2.87
RH1760-2	2 pole sections interconnected by a rigid splice, 1 universal head at one end, rubber base at the other and lace hook	32	2.29	FLV18339-1	2.10	4.63
RH1760-3	With 2 heads (1 at each end) and lace hook	32	1.76	FLV18339-2	1.70	3.75
RH1760-4	With 2 heads (1 at each end) and lace hook	32	2.37	FLV18339-3	2.00	4.41
RH1760-6	Sectional, 2 pole sections interconnected by a rigid seam, universal heads at the ends and lace hook	32	2.25	FLV18339-1	2.40	5.29
RH1760-10	With 2 heads (1 at each end)	32	2.98	FLV18339-4	2.20	4.85
RH1760-12	With 2 heads (1 at each end)	32	3.59	FLV18339-5	2.50	5.51
RH1760-14	With 2 heads (1 at each end)	32	4.20	FLV18339-14	2.85	6.28

Continues on next page ▶

UNIVERSAL POLES

Catalog Reference	Description	Dimensions		Storage (optional)	Approx. Weight	
		Ø (mm)	Insulating Length (m)		kg	lb
RH1761	With 1 head at one end, rubber base at the other and 2 rubber drip skirts	32	2.40	FLV18339-3	1.60	3.53
RH1761-1	With 1 head at one end, rubber base at the other and 3 rubber drip skirts	32	2.40	FLV18339-3	1.70	3.75
RH1770	Folding, with 1 head at one end and rubber base at the other	32	2.30	FLV18339-1	2.00	4.41
RH1790-8	With 2 heads (1 at each end)	38	2.36	FLV18339-3	3.00	6.61
RH1790-10	With 2 heads (1 at each end)	38	2.97	FLV18339-4	3.30	7.28
RH1790-12	With 2 heads (1 at each end)	38	3.58	FLV18339-5	3.70	8.16
RH1790-14	With 2 heads (1 at each end)	38	4.19	FLV18339-14	4.10	9.04
RT403-0752	Sectional, where:					
	1 3m pole section	32	5.93	FLV18339-4	4.75	10.47
	1 3m pole section	38		FLV18339-4		
	It contains 1 rigid splice at its center, 1 32mm universal head at its end and a rubber base in the 38mm section					

TIE STICKS

It has a variety of heads for different applications or even personal preferences of each electrician.

Hook poles (rotary or fixed) are suitable for doing and undoing laces using the eyes at their ends.

The rotary blade pole is used to do and undo laces without eyes at their ends.

Catalog Reference	Description	Dimensions			Storage (optional)	Approx. Weight	
		Ø (mm)	Insulating Length (m)	Total Length (m)		kg	lb
RH1855-25	With rotary prong and rotary blade	32	2.36	2.48	FLV18339-3	1.90	4.19
RH1855-26	With rotary blade and universal head			2.51			



Rotary Prong



Rotary Blade



FLEXIBLE INSULATED WRENCHES

It has a device to receive tools to tighten nuts in energized equipment.

The flexible socket installed on the pole gives the electrician increased flexibility when using this tool, especially at steeper angles. The male-type fixed socket at one end of the RH1891-2 and RH1891-3 poles allows the ratchet wrench (R066780) to be coupled for easy application of the required tightening torque.

The universal head installed at one end of the RH1891-6 pole allows universal tools to be coupled.

Max. torque: 5.5 daN.m (40 ft -1 lb)

The RC403-2136 flexible insulated wrench has a female-type fitting at one end (which allows a R066780 wrench to be adapted) and a 1/2" male fitting at the other. With this, this tool is very versatile by allowing interchanging between two types of socket.

Max. torque: 10 daN.m (75 ft -1 lb)



RH1891-2

Catalog Reference	Pole with	Dimensions		Storage (optional)	Approx. Weight	
		Ø (mm)	Insulating Length (m)		kg	lb
RC403-2136	Female-type flexible socket and fixed socket	38	2.36	FLV18339-3	2.30	5.07
RH1891-2	Male-type flexible socket and fixed socket		1.75	FLV18339-2	2.20	4.85
RH1891-3	Male-type flexible socket and fixed socket		2.36	FLV18339-3	2.60	5.73
RH1891-6	Flexible socket and universal head		2.36	FLV18339-3	2.70	5.95

ACCESSORIES

The hexagonal socket set consists of 11 units measured in inches or 10 units measured with the metric system and is intended to be tightened with the flexible wrench in hot line work.

Its square female socket can be adapted to many other hand socket wrenches or insulating socket poles.

Hex sockets are supplied in a case and arranged in measures in an orderly manner for easy selection.



RC403-1085M

Catalog Reference	Description	Approx. Weight	
		kg	lb
R066780	1/2" male and female manual ratchet socket wrench	0.50	1.10
RC403-1085	Set with 11 long steel sockets, measuring: 1/2", 9/16", 5/8", 11/16", 3/4", 13/16", 7/8", 15/16", 1", 1.1/16", 1.1/8" with case	2.16	4.76
RC403-1085M	Set with 10 long steel sockets, measuring: 10 mm, 11 mm, 12 mm, 13 mm, 14 mm, 15 mm, 16 mm, 17 mm, 18 mm, 19 mm, with case	2.40	5.29



R066780

With the removal of the 1/2" square insert, this tool becomes a female-type model

B

INSULATING GRIP POLE

Designed to hold pliers or other hand tools so they can be used in hot-stick work.

They are available in two versions: including pliers or only the pair of grip poles.

These poles have a head to couple pliers or other compatible tool.



RH1861-1

Catalog Reference	Description	Dimensions		Approx. Weight	
		∅ (mm)	Insulating Length (m)	kg	lb
RH1861-1	Grip pole with pliers	32	1.18	2.00	4.41
RH1861-2	Grip pole only (pair)			1.80	3.97



RH1861-2



WIRE-HOLDING STICK

It is designed for hot-stick work to hold and position conductive cables and jumpers (mainly during sectioning operations), as well as to undo conductor laces in pin insulators.

The lever on the bottom of the pole is responsible for locking the conductor in the jaw. The knurled nut is designed to pre-adjust the opening of the upper head jaw according to the driver size. The two screws with knurled head are designed for locking the lever after mounting to the conductor.

The conductor clamp head can be preset in three positions (left, center and right), so the electrician can maneuver the conductor from favorable working angles. Its opening is designed to handle 6 AWG solid copper cables (\varnothing 4 mm) and even 1590 MCM ACSR aluminum cables (\varnothing 38 mm).

Catalog Reference	\varnothing (mm)	Dimensions		Conductor \varnothing (mm)		Storage (optional)	Approx. Weight	
		Insulating Length (m)	Overall Length (m)	Minimum	Maximum		kg	lb
RC403-3068	32	1.45	1.98	4	38	FLV18339-2	3.30	7.28
RC403-3069		1.89	2.58				3.70	8.16

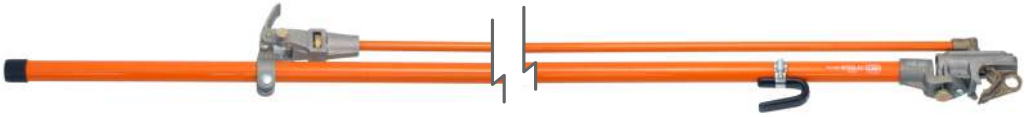

ALL-ANGLE COG WRENCH

The swivel gear mechanism of the all-angle cog wrench allows the electrician to adjust the proper angle for socket placement and nut positioning in hot-stick operations.

The fiberglass pole installed parallel to the tube, attached to the handle, is responsible for stabilizing the gear head, keeping it aligned, even when rotating the pole.

The gear is complemented by a 1/2" square fitting to connect with the sockets that will operate the nuts.

The gear angle can be pre-adjusted up to 140° in relation to the pole using the two wing nuts on the head.

The gear mounting head is made of bronze alloy and the gears are made of special heat-treated steel. This versatile hardware set is installed in the RITZGLAS® tube to ensure the required safety clearance and insulation.



RC403-0184



WARNING

This pole is mechanically sized for nut adjustment only, with a maximum torque of 2.0 daN.m (15 ft-lb).

It must be tighten with the proper torque using the flexible socket pole.

Catalog Reference	Ø (mm)	Dimensions		Storage (optional)	Approx. Weight	
		Insulating Length (m)	Total Length (m)		kg	lb
RC403-0184	38	0.80	1.83	FLV18339-2	2.40	5.29
RC403-0185		1.41	2.44	FLV18339-3	2.90	6.39
RC403-0186		1.98	3.05	FLV18339-4	3.40	7.80
FLV01121-4		2.50	3.67	FLV18339-5	4.20	9.25



VOLT-AMMETER STICK

It has a head at its end that can be adjusted to be coupled to different clamp volt-ammeter models, provided their triggers are on their left side.

The head is plastic-coated to better accommodate the instrument and prevent surface damage. Once coupled to the pole, the clamp voltmeter is activated by a lever on its grip so it can be safely used due to the insulation of the RITZGLAS® tube and tie rod.

In addition to one piece volt-ammeter poles, we have two folding models with the same function and also efficiency as they are easy to carry.

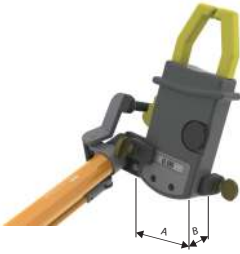

Catalog Reference	Ø (mm)	Dimensions			Instrument (mm)		Approx. Weight	
		Insulating Length (m)	Folded (m)	Total Length (m)	A	B	kg	lb
RH1968-8	32	1.60	-	2.51	38	23	2.35	5.18
RH1978-8*		1.60	1.25	2.51	to 115	to 60	2.80	6.17

* Folding



TOOL RACK AND CROSSARM TOOL HANGER

The pole hanger is a very useful tool in the working area of electrician to rest poles in operation.

It is adjustable on crossarms, ranging in width from 95 to 114 mm (crossarm height is not important).

The paired pole rack is an alternative or complement for the canvas to arrange selected and properly prepared insulating poles in the workplace, thus avoiding their contamination from contact with the ground.

The twelve support rods and center mast are coated with plastic material to protect the poles from abrasion and have a capacity of 12 poles up to Ø 76 mm.

Tripod shoes are fully retractable for easy transport and storage of the rack.



RM1860



RM4660

Catalog Reference	Description	Approx. Weight	
		kg	lb
RM1860	Tool hanger	0.95	2.09
RM4660	One tool rack	3.70	8.16
RM4660-E1	Two tool racks	7.40	16.32

UNIVERSAL TOOLS

The universal tool series in this section has been carefully selected for interventions in energized installations using the universal insulating pole.

These tools are equipped with “toothed” universal heads for their perfect coupling with a universal pole, for hot-stick operations with absolute precision.

Each universal tool has its own properties and its main purpose is to replace manual operation, even if the work angles or positions are unfavorable.

RC403-0005



Cotter pin remover

It is used in disc insulator decoupling to displace the cotter pin when its eye is in the opposite direction of the structure.

Approx. weight: 0.38 kg (0.84 lb)

RC403-0006



Cotter positioner

It is used in disc insulator couplings to insert the cotter pin in its locking position when its eye is in the opposite direction of the structure.

Approx. weight: 0.35 kg (0.77 lb)

RC403-0011



Knocker

Due to the impact caused by its coil spring, this tool is designed for easy extraction of cotter pins when used in with cotter pullers, especially in tight spaces and adverse conditions.

Approx. weight: 0.27 kg (0.60 lb)

RM4455-87



Ball socket adjuster

Designed to position the insulator ball socket during installation or removal. It is also used as an auxiliary tool during cradle installation in “V” chains and when installing tensioner poles.

Approx. weight: 0.30 kg (0.66 lb)

RC403-0126



Ball socket adjuster

Similar to the RM4455-87 ball socket adjuster, this tool is designed to handle objects up to Ø 69 mm.

Approx. weight: 0.32 kg (0.71 lb)

RC403-0175



Ball socket adjuster (plastic coated)

The plastic coating prevents damage to disc insulators or poles during handling.

Approx. weight: 0.35 kg (0.77 lb)

RC403-0177**All-angle pliers**

Designed to hold nuts, fittings, or any other moving parts during intervention. Its wing nut allows pre-adjustment of the best desired angle.

Approx. weight: 0.88 kg (1.94 lb)

ATR10994-1**Multi-angled tong with double jaw**

It has the same application as RC403-0177, but it has a double jaw.

Approx. weight: 1.00 kg (2.20 lb)

FLV30755-1**Pliers for insulator**

Its main application is to hold, guide and move the insulator chain during its installation or removal. Through the lifting eye, the pliers can be used to lift the chain from the ground to the installation site or the reverse operation (taking the chain from the job site and taking it to the ground).

Approx. weight: 1.00 kg (2.20 lb)

RC403-0314**Conductor sander**

Designed to clean the live conductor surfaces before installing grounding connectors or clamps, especially in oxidized copper conductors where cleaning by other methods is difficult

Approx. weight: 0.29 kg (0.64 lb)

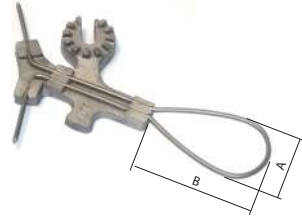
RC403-0834**RC403-1071****Preform wire applicator**

Specially developed for installation or removal of preform wire or lace on live conductors offering rotation control, which is difficult with other tools.

Due to its small size, the RC403-0834 is recommended for top lacing work.

Approx. weight: 0.10 kg (0.22 lb)

Catalog Reference	Ø A (mm)	Ø B (mm)
RC403-0834	27	44.5
RC403-1071	35	76

RC403-1416**Tie wire claw**

Hand-shaped, acts as tweezers to manipulate wires or preformed wires during their installation on the conductor.

Approx. weight: 0.22 kg (0.49 lb)

RC403-1417**Utility-head**

Designed for different interruptions in energized installations, such as: installing or removing blocks, nylon straps, switches, etc.

Approx. weight: 0.24 kg (0.53 lb)

RM4455-2



Pin holder

Designed for the placement and removal of pins in insulator chains through its blade, which holds the pin holder head firmly up to Ø 15 mm during handling.

Approx. weight: 0.21 kg (0.46 lb)

RM4455-5



Cut-Out Tool

Designed for handling the corona ring through its vice-type shape with plasticized hooks.

Max. aperture 75 mm | Ø max. 45 mm

Approx. weight: 0.78 kg (1.72 lb)

RM4455-6



Ratchet wrench

Designed for the handling of bolts and nuts in energized installations through interchangeable sockets. Equipped with a universal rotating screw at its end, it can be used with universal poles.

Approx. weight: 0.69 kg (1.52 lb)

RM4455-9



Disconnect

Special head designed for opening or closing disconnect or fuse switches. Made of aluminum alloy (RM4455-9) and bronze alloy (VMR01479-2).

Approx. weight: 0.06 kg (1.46 lb)

0.17 kg (0.37 lb)

VMR01479-2

RM4455-10



Chuck Blank

Designed to allow the installation of various tools through their welded fixings, making them universal for various interventions in energized installations.

Approx. weight: 0.12 kg (0.26 lb)

RM4455-12



Snapout Cotter Key Remover

Spring-action tool designed to remove cotter pins from insulators in energized installations when its head is directed towards the structure.

Approx. weight: 0.17 kg (0.37 lb)

RM4455-13



Snapout Disconnect

Spring-loaded action tool designed to open stuck disconnect or fuse switches.

Approx. weight: 0.20 kg (0.44 lb)

RM4455-15



Locating Pin

It is used for easy introduction of pins and screws into metal structure fittings and insulator chains when the holes in these fittings need to be aligned.

Approx. weight: 0.32 kg (0.71 lb)

RM4455-17



Fixed Prong Tie Stick Head

Designed for safe operations while performing wire lacings, preventing the end of the wire loop from coming loose and contacting the crossarm.

Approx. weight: 0.18 kg (0.40 lb)

RM4455-18



Cotter Key Installing Tool

Designed for pin or hardware replacement through its clamps, which hold them tightly when they are out of reach of the electrician.

Approx. weight: 0.12 kg (0.26 lb)

RM4455-19



Cotter Key Pusher

Designed to couple and uncouple insulators.

The straight end allows the cotter pin to move from the inner shell housing, while the curved portion is used to push the cotter pin back into the housing.

Approx. weight: 0.33 kg (0.73 lb)

RM4455-22



Ball Socket Adjuster

Shaped like a hook, it is designed to manipulate the socket position during the cotter pin installation or removal.

Approx. weight: 0.34 kg (0.75 lb)

RM4455-23



Hack Saw

Designed to cut components close to the live conductor, even at unfavorable angles.

Approx. weight: 0.42 kg (0.93 lb)

RM4455-26A



Pruning Saws

Designed to saw tree branches near energized installations.

Approx. weight: 0.36 kg (0.79 lb)

RM4455-66



Saw handle

This tool acts as a handle for the pruning saw RM4455- 26A, for rubber glove work.

Approx. weight: 0.20 kg (0.44 lb)

RM4455-28



Screwdriver

Designed for the installation and removal of slotted head screws in energized installations.

Approx. weight: 0.12 kg (0.26 lb)

RM4455-29B



Head for clamps up to 152 mm

Designed for the installation and removal of eyescrew clamps in energized or non-energized installations.

Approx. weight: 0.30 kg (0.66 lb)



RM4455-36**Link Stick Head**

It is designed to hold light components or conductors during interventions in energized installations. It has an aperture capacity of 6 to 19 mm. Body edges are rounded to prevent damage to conductors.

Approx. weight: 0.36 kg (0.79 lb)

RM4455-37**Chuck Blank**

Designed for the coupling of various tools. with a firm attachment through a wing nut. making them a universal tool for the different energized interventions.

Approx. weight: 0.14 kg (0.31 lb)

RM4455-38**Mirror**

Designed for inspections in energized installations not directly visible. The angle of the concave mirror can be preset. to give the electrician a better working position.

Approx. weight: 0.37 kg (0.82 lb)

RM4455-39**Shepherd Hook**

For handling and lifting insulator chains. Its articulation is designed to maintain alignment with the insulator at all times.

It is also used as a support during interventions in energized installations. such as: pole or yoke installations.

Approx. weight: 0.30 kg (0.66 lb)

RM4455-40**Fixed Blade Tie Stick Head.**

It has a blade with a 60° tilt in relation to the pole. for lace wire handling.

Provided with deep V-shaped for easy wire extraction. even in hard to reach places.

Approx. weight: 0.20 kg (0.44 lb)

RM4455-46**Flexible Wrench Head**

Designed for fitting to 1/2" standard sockets when installing or removing bolts or nuts.

Approx. weight: 0.42 kg (0.93 lb)

RM4455-50**Skinning Knife**

Allows cutting objects or removing conductor insulation in energized installations.

Approx. weight: 0.11 kg (0.24 lb)

RM4455-63**RM1889****Conductor Cleaning Brush**

It has steel bristles for excellent pressure around the conductor during cleaning. Available in models RM4455-63. with a universal socket for coupling to a universal stick. and RM1889. with a grip for manual use (when used with rubber insulating gloves). Steel bristles may be purchased for replacement in packages with 10 units: (RM1899).

Approx. weight: 0.17 kg (0.37 lb)

0.36 kg (0.79 lb)

RM4455-64



Extension with drip skirts
This tool is designed for coupling on insulating poles for use in emergency situations under rain.
Approx. weight: 1.10 kg (2.42 lb)

RM4455-71



Pointed Disconnect
A head used for circuit breaker switch operation.
Approx. weight: 0.09 kg (0.20 lb)

RM4455-67

RT403-1101



Insulator Forks
Designed to hold the insulator during its installation or removal.
With a pre-set angle on the wing nut, and by turning the screw, the fiber jaws are adjusted from 76 to 108 mm (3" to 4-1/4") on model RM4455-67, and 57 to 89 mm (2 1/4" to 3-1/2") on model RT403-1101.
Approx. weight: 1.06 kg (2.34 lb)

RM4455-72



Conductor Gauge
It is designed for fast and accurate gauge measurement of ACSR, solid or multi-stranded copper conductors, for 4 Cu up to 4/0 ACSR.
Approx. weight: 0.08 kg (0.18 lb)

RM4455-69



Rotary Prong Tie Stick Head
It has free rotary prong at its ends to do and undo laces.
Approx. weight: 0.30 kg (0.66 lb)

RM4455-77



Fuse Puller
With universal fit, it is designed to install, mobilize, or remove Ø 13 to 38 mm fuse switch cartridges in energized installations by rotating the universal pole. The cartridge puller angle can be pre-set using the wing nut.
Approx. weight: 0.97 kg (2.14 lb)

RM4455-70



Rotary Blade Tie Stick Head
A tool with a V-shaped steel blade and free swivel on its axis.
It is used to undo laces without eye at its end.
Approx. weight: 0.26 kg (0.57 lb)

RM4455-78



Fuse Puller
Similar in application to model RM4455-77, this tool has an aperture capacity of 25 to 64 mm.
Approx. weight: 1.0 kg (2.20 lb)



FLV03811-3



Fuse Puller

Designed to install mobilize. or remove Ø 30 to 90 mm fuse switch cartridges in energized installations by rotating the universal pole.

Approx. weight: 1.40 kg (3.09 lb)

RC403-2270



Aerosol can holder

Intended for safe application of paint and lubricant to energized equipment in hard-to-reach places or insecticide to bee and wasp nests. on poles and crossarms.

Optional: CPR-30485 - Protective Cover for Aerosol Applicator.

Approx. weight: 0.21 kg (0.46 lb)

RM4455-79



Spiral Disconnect

It is designed for several tasks. such as:

- opening yoke locks to release trunnions or adjustable sleeves on tensioning poles;
- assisting in installing energized side yokes;
- cable tensioner mounting and removal.

Approx. weight: 0.18 kg (0.40 lb)

RM4455-80



Tree and Rope Hook

Designed for pushing/pulling tree branches out of the work area near energized installations or to untangle ropes.

Approx. weight: 0.15 kg (0.33 lb)

RM4455-82



All Purposes Cotter Key Tool

Specially designed for installing and extracting cotter pins in insulator anchor chains.

It has guiding slots for the cotter pin during mounting.

Approx. weight: 0.09 kg (0.20 lb)

RM4455-84



Universal adapter

It is provided with a thumbscrew to couple to a universal head. allowing the change of the installation angle of a tool.

Approx. weight: 0.11 kg (0.24 lb)

RM4455-85



Hammer

Designed for you to strike hard in energized installations to move them.

Approx. weight: 0.42 kg (0.93 lb)

RM4455-86



Vise Grips Holder

Designed to be a temporary anchor for the ends of cut conductors during maintenance to prevent them from becoming loose.

Approx. weight:0.13 kg (0.29 lb)

RM4455-88



Bolt Head Wrench

It acts as a fixed wrench for Ø 3/4" and 5/8" bolts, preventing them from turning when the nut is moved with the RM4455-89 ratchet wrench and RC403-1085 and RC403-1085M multi-angle sockets.

Approx. weight:0.42 kg (0.93 lb)

RM4455-89



Ratchet Wrench

Designed to tighten 5/8" square nuts on energized installations hardware, regardless of thread length.

Approx. weight:1.19 kg (2.62 lb)

FLV16165-1



Universal Extension Device

This tool is designed for the extension, in certain cases, of other universal tools in hard to reach places.

Approx. weight:0.15 kg (0.33 lb)

RM4455-92



Conductor Cleaning Brush

It has a semitubular shape with Ø 64 mm external length and a swivel head with universal fit for use for coupling to universal poles. Designed to clean the whole circumference of an energized conductor.

Approx. weight:0.53 kg (1.17 lb)

RM4455-93



Conductor Cleaning Brush

Similar to model RM4455-92 (Ø 64 mm), for manual use with the aid of insulating gloves for increased safety.

Approx. weight:0.30 kg (0.66 lb)

RC403-0320

(Ø 64 mm external)

RC403-0450

(Ø 76 mm external)



Conductor Cleaning Brush

Also similar to the RM4455-92 model, it has a plastic coated steel handle for better grip for electricians, who should wear insulating gloves during handling.

Approx. weight:0.22 kg (0.49 lb)

0.45 kg (0.99 lb)

RM4455-96



Cotter key Puller

It is designed for easy partial extraction of the cotter pin through its "petal" shape that, by moving the lever, gently extracts the cotter pin that is perpendicular to the structure.

Approx. weight:0.28 kg (0.62 lb)

RM4455-97



Tool for "W" keys

Designed for replacement of W-type cotter pins (commonly used in Europe and Japan) using its slot.

Approx. weight:0.22 kg (0.49 lb)

RM4455-100



Flexible Universal Adapter

This tool is designed to rotate another universal tool in series with it, even at an angle when coupled to a universal pole or hot stick.

Approx. weight:0.72 kg (1.59 lb)

RM4455-102



Pin Installer

This tool allows the placement of pins in insulator chains through its three tightly grasping clamps.

Approx. weight:0.40 kg (0.88 lb)

RM4455-103



Cotter Key Installing Tool

This tool is designed for the installation of angled cotter pins in the insulator chains through its multi-snap device.

Approx. weight:0.26 kg (0.57 lb)

FLV16148-1



Universal Hook

This tool is designed for handling objects up to Ø 64 mm.

Approx. weight:0.34 kg (0.75 lb)

FLV16159-1



Rubber Coated Hammer

Designed to strike equipment in energized installations to move them.

Approx. weight:0.40 kg (0.88 lb)

FLV11042-1



Boat-hook Tool

Used by firefighters to break glass, roofs, etc. to clear places that need to be accessed, such as buildings, homes, sheds after a fire, reducing accidents.

Approx. weight:0.85 kg (1.87 lb)

B

FLV29611-1

Spacer mounting head

A tool with a toothed universal head designed for hot-stick work with absolute precision. It has cast aluminum body with a red plastisol coated section. in order to improve distance visibility of the tool.

Approx. weight: 0.20 kg (0.44 lb)



LEVER TYPE WIRE CUTTERS

Designed to cut ACSR, ASC, and copper aluminum cables, made with RITZGLAS® insulating tube.

The hinged handle cutter (FLV02818-1) is only used for lower effort cuts and is exclusive for rubber glove work interventions.

Lever models have reinforced fiberglass poles that drive the blades.

The lever is plastic coated and driving it gives the electrician additional mechanical force when cutting conductors in the sizes indicated in the table.

HINGED-TYPE LEVER CUTTER

Catalog Reference	Maximum Conductor Size	Dimensions		Approx. Weight	
		Ø (mm)	Total Length (m)	kg	lb
FLV02818-1	1/0 CAA Ø 10.11 mm	32	0.76	2.50	5.51



FLV02818-1

SIMPLE HANDLE CUTTER

Catalog Reference	Maximum Conductor Size	Dimensions		Approx. Weight	
		Ø (mm)	Total Length (m)	kg	lb
FLV19245-1	556 MCM CAA (ACSR) Ø 23.5 mm	38	0.81	2.60	5.70



FLV19245-1

LEVER TYPE WIRE CUTTERS

Catalog Reference	Maximum Conductor Size	Pole Dimensions			Approx. Weight	
		Ø (mm)	Insulating Length (m)	Total Length (m)	kg	lb
RH1871-4	1/0 CAA (ACSR) Ø 10.11 mm	32	0.71	1.45	3.45	7.50
RH1871-6	1/0 CAA Ø 10.11 mm	32	1.16	2.00	4.00	8.82
RH1873-4	4/0 CAA Ø 14.31 mm	38	0.71	1.45	5.40	11.90
RH1873-6	4/0 CAA (ACSR) Ø 14.31 mm	38	1.16	2.00	6.00	13.20
RH1875-4	336,8 MCM CAA Ø 18.83 mm	38	0.71	1.45	6.00	13.20
RH1875-6	336,8 MCM CAA Ø 18.83 mm	38	1.16	2.00	6.80	15.00

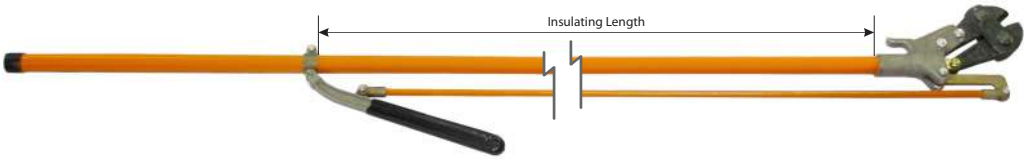

B

RATCHET CABLE CUTTERS

Catalog Reference	Maximum Conductor Size	Pole Dimensions			Approx. Weight	
		Ø (mm)	Insulating Length (m)	Total Length (m)	kg	lb
RC403-1382	556 MCM CAA Ø 23.5 mm	38	0.79	1.97	5.20	11.46
RC403-1384	556 MCM CAA Ø 23.5 mm	38	1.40	2.58	5.50	12.13

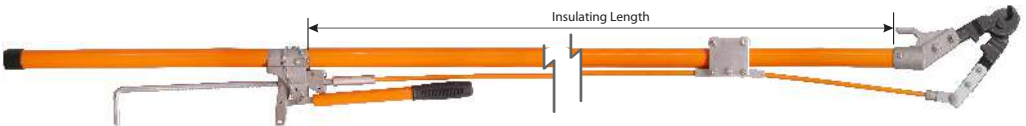

The construction of these cutters, with plastic caster system, provides a smooth sliding mechanism over the RITZGLAS® tube and reinforced fiberglass rods.

TREE TRIMMERS

It is designed to cut tree branches, especially in the vicinity of electrical installations, when branches obstruct interventions or compromise operation and safety.

The fixed and movable blade is made of forged steel and is sharp. The pulley system, giving the operator a 3 x 1 mechanical advantage (for example: a 4.5 daN (10 lb) force on the rope) will represent a 13.5 daN (30 lb) force on the blades.

Pulleys were adopted to reduce operating effort.

The handle (\varnothing 1/4") of the tree trimmer is 7.60 m long.

The RH2106-4 is designed to be coupled to complementary poles using a universal head.

The tree trimming also has a universal slot close to the blade for mounting a branch pruning saw.

Catalog Reference	Pole with	Dimensions		Approx. Weight	
		\varnothing (mm)	Working length (m)	kg	lb
RH2106-4	Branch pruner with universal head	32	0.66	1.70	3.75



ACESSÓRIO

Catalog Reference	Description	Approx. Weight	
		kg	lb
RM4455-26A	Branch pruning saw	0.36	0.80



RM4455-26A

UNIVERSAL TOOL HEAD FOR CUTTING WIRES

It is used to shut off power of consumers in default when the power meter is not accessible. It can also be attached to the hot stick without requiring ladders.

This head has a 15 mm opening, to cut conductors up to 35 mm² (2 AWG).

Catalog Reference	Description	Approx. Weight	
		kg	lb
FLV17844-1	Universal tool head for cutting wires	0.30	0.66



KITE BUSTER TOOL

Practical for the removal of kites and intertwined wires in the electric networks, especially in urban areas, situations that cause serious risks to system operation and negatively affects the visual aspect.

This tool is used at the end of the hot stick through by connecting it to the universal head.

It was built with Ø 25 mm x 300 mm RITZGLAS® tube in total length and has steel cross pins in its body to tie the wires attached to the power grid.

The upper end of this tool can be coupled with other head models for cutting and removing objects from electrical networks.



FLV13907-1

Catalog Reference	Description	Approx. Weight	
		kg	lb
FLV13907-1	Kite buster tool	0.31	0.68



FLV09311-1

The sharp blade head (FLV09311-1) has universal fitting for hot stick operation, an accessory for Kite buster tool where could be attached to the top end of this tool. There is a sharp cutting blade. Upper side blade and downside blade for enhanced performance.

The universal sharp blade head (FLV30173-1) has its own characteristics for cutting and removing objects from the network. Made with universal aluminum alloy head and "U" shaped blade, the blade edge internal for easy cutting.



FLV30173-1

ACCESSORY

Catalog Reference	Description	Approx. Weight	
		kg	lb
FLV09311-1	Flange Universal Head	0.16	0.35
FLV30173-1	Universal Head with blade	0.11	0.24

CONDUCTOR STRIPPER

FVR BXQ-Z-40A

Tool used to remove the polymeric protective cover on protected copper and/or aluminum conductors, used in electricity distribution networks, without damaging the conductors. Suitable for shielded conductors with a diameter ranging from 14 to 40 mm, with a coating thickness of up to 6 mm.

The cutting blade is made of alloy steel, where it is sharpened after being ground and heat treated. It is an easy-to-remove component (for replacement or sharpening) and its positioning in the tool facilitates the operation of stripping the conductor, allowing the operation to be visualized.

The stripping operation can be carried out at the ends and in the middle of the conductor, simply positioning the tool in the desired location. It is an easy-to-use tool and guarantees an excellent quality of finish.

Approx. weight: 1.00 kg (2.20 lb)



POLE HANDLING TOOLS

It is made with RITZGLAS® tube (Ø 51 mm) and designed to rotate poles or other cross-sections (hexagonal, square) made of wood, metal or concrete for mounting positioning.

RC305-0021

It has a 48 mm wide and 1.83 m long nylon strap and has a capacity of up to 3402 daN (7500) lbf tensile strength, firmly gripping the posts up to Ø 480 mm, including smooth surfaces.

Insulate length: 1.22 m;

Approx. weight: 2.90 kg (6.39 lb)



RC305-0021

RC305-0008

It has an articulated galvanized steel hook at its fixing end which is also adjustable. So it can grab wooden posts of different diameters.

Insulate length: 0.91 m;

Approx. weight: 3.40 kg (7.50 lb)



RC305-0008

RC200T

It has jaws to grab poles from Ø 180 to 406 mm.

Insulate length: 0.85 m;

Approx. weight: 6.00 kg (13.22 lb)



RC200T

B

AUXILIARY STICK FOR POSITIONING ON UTILITY POLES INSTALLATION



A tool to aid in the movement of utility poles composed of rotary drive stem, made of Ø 32 mm RITZGLAS® insulation tube, with non-slip grooving, fixed threaded head, mobile head and support shoe. It also has polyester strap with protector, triggered by ratchet, which enables the attachment of the tool to the utility pole.

Stick to assist in the movement of utility poles, during their installation and removal, with the purpose of maintaining the electrician safe, avoiding the risk of electric shock due to accidental utility pole contact with the energized network. The insulation stem holds the electrician away from the utility pole and allows through rotary movements, the repositioning of the tool.



Catalog Reference	Insulating Length (mm)	Total Length (mm)	(A) Utility Pole Work Diameter (mm)	Approx. Weight	
				kg	lb
FLV30841-1	650	1710	250 a 300	7.65	16.86

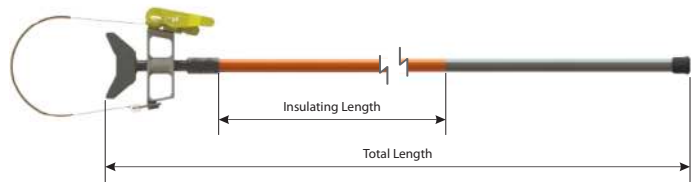

RESCUE HOOK

Designed for electrical accident rescue in installations up to 34.5 kV, this pole with anatomically designed hooks ensures the required safety clearance and insulation, making emergency and adverse interventions practical, quick, and safe..

It is built with a RITZGLAS® tube, the same used in hot line maintenance tools. It has decreased weight, high mechanical strength, and excellent dielectric strength, essential characteristics for easy handling and total safety.

The RITZGLAS® Rescue Stick should only be used to move the victim away from energized points. Removing the victim should be sufficient for safe first aid.

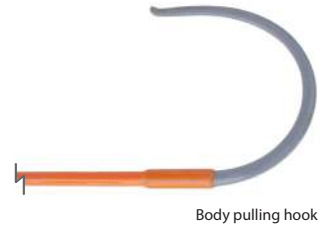
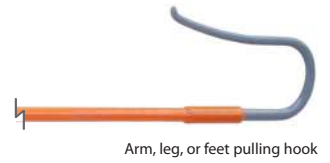

Catalog Reference	Ø (mm)	Rated Work Capacity		Length (m)	Approx. Weight	
		daN	lb	Total	kg	lb
FLV09429-1	32	200	440	2.25	2.70	5.95

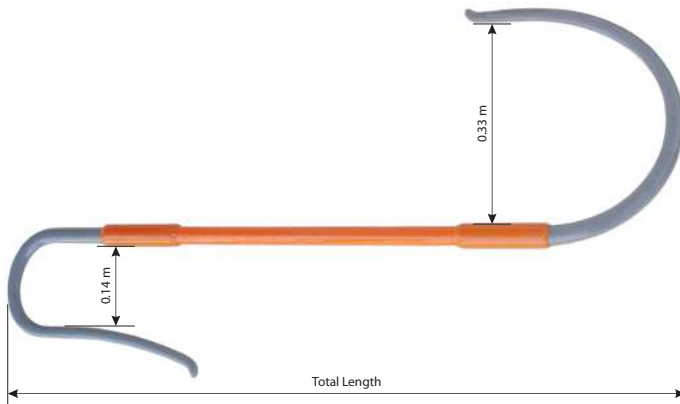

B

MEASURING STICK AND EXTENSION

Designed to measure lengths and gaps up to 3 m in energized systems when minimum recommended safety distances cannot be maintained.

It comprises of RITZGLAS® insulating poles with alternating 10 cm markings, in orange and black colors, hooks, and universal connections made of aluminum and bronze alloy.

It has a versatile design, enabling measurements at angles.

Easy to handle, it can be used with the rubber glove method or with a hot stick connected to its universal head.

For measurements of lengths over 3 m, the FLV16146-1 extension must be coupled to the set.

Catalog Reference	Description	Ø (mm)	Total Length (m)	Approx. Weight	
				kg	lb
FLV16140-1	Measuring stick	9.50	3.00	0.80	1.76
FLV16146-1	Extension	16.00	2.00	1.00	2.20



FLV16140-1



FLV16146-1



Access our site.

COVER-UP AND INSULATING RUBBER



Application, Handling and Conservation ...	115	Compact System Cover.....	124
Pole Covers	117	Transformer Bushing Cover.....	124
Round Covers	118	Insulating Covers for Maintenance Works on Energized Substations	125
Crossarm Covers	119	Permanent Covers.....	127
Pole Top Cover	120	Insulated Rubber Blanket.....	129
Fuse-Switch and Switch Cover	120	Flexible Cover for Conductors	130
Conductor, Pin and Disc Insulator Covers.....	121	Rubber Insulating Gloves and Sleeves	132
Secondary Conductor Cover (LV)	123	Removable Protective Cover.....	135

COVER-UP AND INSULATING RUBBER



APPLICATION, HANDLING AND CONSERVATION

Hot line protective covers are one of the main protective equipment for interventions in low and medium voltage energized installations.

They are designed to electrically protect the entire work area in order to prevent accidental phase-to-phase or phase-to-ground contacts during service.

They are used in rubber glove work in energized lines and must be installed with rubber insulating gloves or with from a distance, as they have metallic brackets (eyebolts) for hot sticks.

They should only be used by suitably trained electricians for hot line work and requires the following basic rules to be observed:

1. Under no circumstances should the electrician touch the covers except with rubber gloves. Therefore, the electrician should always be aware of his/her position in relation to them to avoid accidentally touching them..

This rule is valid for any other Cover used to protect energized parts.

2. Protective covers for poles, crossbars, horizontal supports, C-support, and round covers are designed to prevent accidental contact of energized conductors or cable ties with grounded surfaces of the structure.
3. Protective covers should be handled with care to avoid breaking, cracking, or scratching and should always be kept clean and dry.
4. Each protective cover should be carefully inspected prior to use for cracks, deep scratches, deformation, or other damage, and to check that they are clean and dry.

If necessary, it must be cleaned only with cotton fabrics. If dirt cannot be completely removed, use mild soap and water.

5. Unlike permanent protective covers, which will be addressed at the end of this group, protective covers are designed for temporary use to perform a variety of hot line maintenance tasks, and must be removed after the service.



CAUTION

Hot line protective covers are designed for a wide variety of power system maintenance situations, and we provide appropriate covers for each type of equipment for increased efficiency and safety.

The electrician must carefully select the most suitable covers and in the necessary amounts, to avoid dangerous improvisations before any task.

A visual inspection of the covers for cracks, deep scratches, dirt, deformations, etc. is imperative for all hot line teams, because user safety depends on perfect equipment maintenance. When in doubt, the covers must not be used and sent for electrical testing.



TECHNICAL CHARACTERISTICS

Hot line protective covers are made of high dielectric, UV, and ozone resistant thermoplastic.

Its orange color allows excellent visualization of the area under intervention.

Protective covers for hot stick work have metallic brackets for stick operation.

POLE COVERS

It is used for insulating protection for pole mounting or changing operations.

They have internal ribs, an important detail to prevent surface abrasions during handling, decisively extending their useful life, with polypropylene rope handles for easy mounting and removal with insulating gloves.

Models with 1200 and 1800 mm lengths have a nylon button to couple two or more units to protect a longer pole length.



COVER FOR POLES UP TO Ø 150 mm

Catalog Reference	Dimensions (mm)			Approx. Weight	
	A	B	C	kg	lb
RC406-0548	300	150	~115	0.70	1.54
RC406-0549	600			1.20	2.65

Rated voltage 36.6 kV (phase/phase)

COVER FOR POLES UP TO Ø 230 mm

Catalog Reference	Dimensions (mm)			Approx. Weight	
	A	B	C	kg	lb
RM4937-1	300	230	~195	1.00	2.20
RM4937-2	600			1.95	4.30
RM4937-4	1200			3.95	8.71
RM4937-6	1800			5.95	13.12

Rated voltage 36.6 kV (phase/phase)

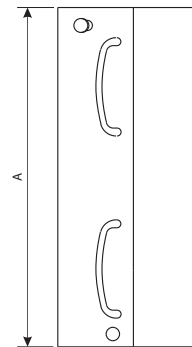

C

COVER FOR POLES UP TO Ø 300 mm

Catalog Reference	Dimensions (mm)			Approx. Weight	
	A	B	C	kg	lb
RC406-0028	300	300	~115	1.15	2.54
RC406-0029	600			2.35	5.18
RC406-0030	1200			4.85	10.69
RC406-0000	1800			7.20	15.87

Rated voltage 36.6 kV (phase/phase)

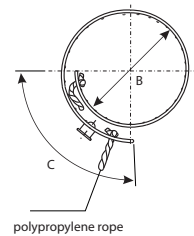

ROUND COVERS

Due to their versatility, these covers are used to protect pole ends, braces, crossarm, lightning arresters, etc.

As its application is not specific, each use deserves special care in order to ascertain the real protection that the cover offers.

It has a polypropylene rope strap for easy installation and removal with insulating gloves.

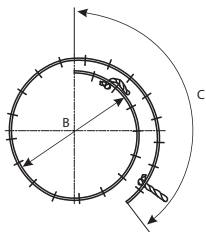
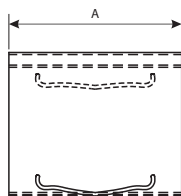

ROUND COVER TO Ø 100 AND 150 mm

Catalog Reference	Dimensions (mm)			Approx. Weight	
	A	B	C	kg	lb
COB11176-1	300	100	~196	0.40	0.88
COB11176-2	600			0.80	1.76
COB11176-3	900			1.20	2.65
COB11176-4	1200			1.60	3.53
COB04487-1	300	150	~135	0.50	1.10
COB04487-2	600			0.90	1.98
COB04487-3	900			1.30	2.87
COB04487-4	1200			1.80	3.97

Rated voltage 26.4 kV (phase/phase)

CROSSARM COVERS

Its main application is to prevent the contact of cable ties with the crossarm in pin insulator or post insulator replacement operations.

They can also be used to hold the temporary jumper or conductor over the crossarm. Conductors must be protected with an appropriate covers.

Three models are available, one for crossarms with pin insulator and others for crossarms with post insulator.

Catalog Reference	Description	Length (mm)	Approx. Weight	
			kg	lb
RM4933	With pin insulator	610	1.45	3.20
COB11173-1	With post insulator	570	1.50	3.31
COB11173-2	Short type, with post insulator	430	1.10	2.43

Rated voltage 36.6 kV (phase/phase)



Crossarm End Cover

It is used to protect crossarm ends against accidental contact with the cable tie during mounting or removal.

With the rubber glove method this cover also helps to prevent the electrician from contacting the earth potential.

The RC406-0102 can be used on crossarms with pin or post insulators as it has a bolt groove for double crossarm mounting.

Catalog Reference	Description	Approx. Weight	
		kg	lb
RC406-0102	Crossarm end cover	1.25	2.75
COB14780-1	Crossarm end cover	0.71	1.57
COB10765-1	Cover for disconnect switch housing	0.68	1.50

Rated voltage 36.6 kV (phase/phase)



POLE TOP COVER



Rated voltage 36.6 kV (phase/phase)

RC406-0097

It is used to protect pole tops during cable tie installation and removal operations.

It adapts to poles up to Ø 254 mm. It has an elastic rope for better mounting.

Approx. Weight: 2.10 kg (4.63 lb)

FUSE-SWITCH AND SWITCH COVERS



RC406-0009

It is used as protection in structures with fuse or disconnect switches, and can be installed using rubber glove and hot-stick methods.

The RC406-0009 cover is secured by a pin that locks it behind the insulator and rests on the metal switch bracket.

Model COB28494-1 is wrapped around the two insulator shrouds, which are compressed in place.



COB28494-1

The COB13345-1 cover is used for insulating protection between the disconnect switch housing and live parts during jump installation and removal operations or other work on the switch. Designed for 15 and 23 kV networks, it consists of two flat plates, which, when half-open, can be wrapped around the base of the insulators and locked by insulating nuts.



COB13345-1

Catalog Reference	Description	Rated Voltage kV (phase/phase)	Approx. Weight	
			kg	lb
RC406-0009	Protective cover for fuse switch	26.4	2.80	6.17
COB28494-1	Protective cover for disconnect switch	36.6	2.90	6.39
COB13345-1	Protective cover for disconnect switch housing (365 x 880 mm)	26.4	2.00	4.41

CONDUCTOR, PIN AND DISC INSULATOR COVERS

Conductor Cover

It provides a greater protection area in energized parts and therefore the most commonly used in hot line work

Available in many models to suit various types of electrical installations with rated voltages up to 48.3 kV.

Their ends are provided with a male/female fitting, for firm connections with two or more units or other models, such as pin insulator covers and disc insulator covers.

Specifically, RP406-0184/RC406-0181GA/RC406-0514GA also allow connections with rubber conductor covers.

The metal eye ring clips are designed to mount the covers on the network with a hot-stick.

Specifically for covers RP406-0184 and COB03335-1, this is an option for users who wish to mount them using the rubber glove method.

With a universal head mounted at the end of this stick, the mounting angle of the cover can be pre-adjusted.

Pin Insulator Cover

They are designed to protect an energized conductor next to a pin or post insulator, and are normally used with conductor covers to which they can be coupled through standard fittings.

One of its sides can be adjusted for better a fit in many crossarm widths.

There are several models available, which vary according to application and operating voltage.

Some have metallic brackets for hot-stick work, and others have no metallic brackets for rubber glove work.

Disc Insulator Cover

It establishes protection of live parts near disc insulators in anchor chains.

They have fittings on both ends, one to couple to the insulator and the other to couple to the conductor cover. Some are equipped with a metallic bracket for the hot-stick work and an elastic strap for better mounting of the edges.

Applicable for both conventional and polymeric insulators.

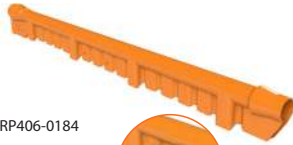

RP406-0184



RC406-0181GA
Metallic bracket for hot-stick



RC406-0182L



RC406-0164

COVER SET CONDUCTOR / PIN INSULATOR / DISC INSULATOR

Catalog Reference	Application	Description	Approx. Weight	
			kg	lb
RP406-0184	Conductor	For rubber glove work For conductors up to Ø 25 mm Approx. length 1.560 mm	1.50	3.31
RC406-0181GA	Conductor	For hot-stick work For conductors up to Ø 25 mm Approx. length 1.560 mm	1.60	3.50
RC406-0182	Pin Insulator	153 mm Height with metallic bracket for hot stick	1.10	2.43
RC406-0182L	Pin Insulator	229 mm Height with metallic bracket for hot stick	1.20	2.65
RC406-0164	Disc Insulator	Protection for discs up to Ø 254 mm	4.30	9.48

Rated voltage 26.4 kV (phase/phase)



RC406-0514GA



RC406-0557L

COVER SET CONDUCTOR / PIN INSULATOR

Catalog Reference	Application	Description	Approx. Weight	
			kg	lb
RC406-0514GA	Conductor	For hot-stick work For conductors up to Ø 25 mm Approx. length 1.530 mm	2.15	4.74
RC406-0557	Pin Insulator	305 mm Height with metallic bracket for hot stick	1.10	2.43
RC406-0557L	Pin Insulator	419 mm Height with metallic bracket for hot stick	1.40	3.09

Rated voltage 36.6 kV (phase/phase)



COB03335-1



RM4946
Metallic bracket for hot-stick



RM4947



COB11400-1

COVER SET CONDUCTOR / PIN INSULATOR / DISC INSULATOR

Catalog Reference	Application	Description	Approx. Weight	
			kg	lb
COB03335-1	Conductor	For rubber glove work For conductors up to Ø 25 mm Approx. length 1.560 mm	0.90	1.98
RM4946	Conductor	For hot-stick work For conductors up to Ø 25 mm Approx. length 1.560 mm	1.25	2.76
RM4947	Pin Insulator	With Metallic bracket	0.70	1.54
COB11400-1	Pin Insulator	Dead end, polymer, porcelain rigid and disc insulators up to Ø 160 mm	1.30	2.87

Rated voltage 26.4 kV (phase/phase)

COVER SET CONDUCTOR / PIN INSULATOR

Catalog Reference	Application	Description	Approx. Weight	
			kg	lb
COB08835-1	Conductor	For rubber glove work For conductors up to Ø 25 mm. Approx. length 1.460 mm	2.50	5.51
RM4948	Disc insulator	With metallic bracket for hot stick	2.95	6.50

Rated voltage 36.6 kV (phase/phase)



COVER SET CONDUCTOR / PIN INSULATOR

Catalog Reference	Application	Description	Approx. Weight	
			kg	lb
RM4931	Conductor	For hot stick work For conductors up to Ø 45 mm. Approx. length 1.525 mm	4.20	9.26
RC406-0046	Pin insulator	With metallic bracket for hot stick work	3.90	8.60

Rated voltage 48.3 kV (phase/phase)



SECONDARY CONDUCTOR COVER (LV)

Rated voltage 14.6 kV (phase/phase)

COB03333-1

It was designed for temporary mounting in secondary networks up to Ø 25 mm, in order to avoid accidental human or tool contacts with low voltage conductors during maintenance around the pole or even in medium voltage work.

One of its great advantages is that it is lightweight and can be coupled with other units of the same type through its male-female system, to insulate long extensions.

This cover has no metallic brackets, so it must be mounted in the network with the rubber glove method.

Approx. length 1.320 mm

Approx. Weight: 0.45 kg (0.99 lb)

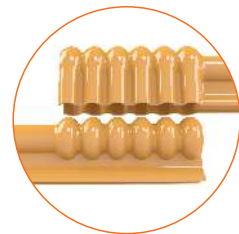

COMPACT SYSTEM COVERS



COB11147-1

Rated voltage 36.6 kV (phase/phase)

COB11147-1

For spacer cable system conductors up to \varnothing 25 mm.

Approx. length 880 mm

Approx. Weight: 0.90 kg (1.98 lb)



COB11047-1

Rated voltage 26.4 kV (phase/phase)

COB11047-1

Protective cover for horizontal support when changing pin insulators.

Composed of two parts, which are installed overlap, providing full protection of the supports.

Approx. Weight: 1.25 kg (2.76 lb)



COB11170-1

COB11170-1

Protective cover for protection of the supports when changing pin insulators. Applied in type "C" support. Each model is composed of two parts, which are overlaid, providing full protection of the supports.

Approx. Weight: 1.10 kg (2.43 lb)



COB11170-2

COB11170-2

Protective cover for protection of the supports when changing post insulators. Applied in type "C" support. Each model is composed of two parts, which are overlaid, providing full protection of the supports.

Approx. Weight: 1.25 kg (2.76 lb)

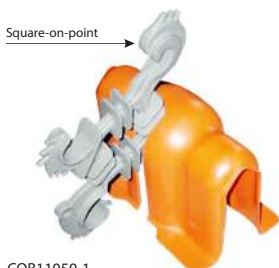

COB11050-1

COB11050-1

Protective cover for lozenge-shaped spacers, its main function to protect the conductor near the lozenge-shaped spacers.

Approx. Weight: 0.70 kg (1.54 lb)



COB11051-1

COB11051-1

Protective cover for pin insulator. It has clip and rope for fixing the set thus avoiding its accidental displacement.

Approx. Weight: 0.80 kg (1.76 lb)



COB30064-1

Rated voltage 26.4 kV (phase/phase)

COB30064-1

It is designed for insulating protection of the transformer bushing assembly and temporary jumper for transformer bushings. A protective cover made of rigid polyethylene with high dielectric strength, resistant to ozone and UV.

Approx. Weight: 0.78 kg (1.70 lb)

TRANSFORMER BUSHING COVER

INSULATING COVERS FOR MAINTENANCE WORKS ON ENERGIZED SUBSTATIONS

The insulating cover set consists of:

- Side Guard;
- Cover for fixed contact of the disconnect switch;
- Straight cover for buses;
- Adapter and mounting head protect adjacent circuits, fixed disconnect contacts and buses, providing a safe working condition and preventing accidental contacts with energized parts.

The versatility of this set offers protection for disconnect switches of: 630 A and 1250 A - one-pole and 1250 A - three-pole, and others.

Quick mounting and unmounting with conventional hot stick.

Side Guard

Mounted on adjacent bays closest to the gantry to be insulated, providing full protection to the operator and the work area. Mounted to the structure by removable fiberglass hooks, for different installation positions.

Catalog Reference	Description	Dimensions (mm)		Approx. Weight	
		A	B	kg	lb
COB11612-1	Substation Side Guard with vertical Installation	1430	730	7,05	15,54
COB22404-1	Substation Side Guard with vertical Installation	1800	740	9,45	20,83
COB26095-1	Substation Side Guard with horizontal Installation	1800	740	9,45	20,83

Rated voltage 26.4 kV (phase/phase)

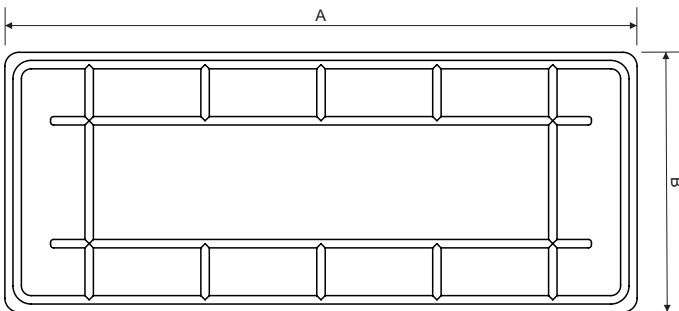

COB11612-1



C



vertical installation



horizontal installation

Cover for Disconnect Switch Fixed Contact

It is designed to insulate the fixed contact of the disconnect switch Ø 250 mm. It has removable and adjustable mounting hooks for different types of switches, as well as different truss dimensions.



COB11617-1

Catalog Reference	Rated Voltage (phase/phase)	Dimensions (mm)		Approx. Weight	
		Length	Height	kg	lb
COB11617-1	14.6 kV	620	500	2.65	5.84
COB20663-1	26.4 kV	660	660	5.98	13.18

Straight Cover for Buses

Similar to the conductor cover for hot line work. It offers a wide protection range when insulating energized buses up to Ø 58 mm near the work area.



COB11622-1

Catalog Reference	Rated Voltage (phase/phase)	Dimensions (mm)		Approx. Weight	
		Length	Height	kg	lb
COB11622-1	14.6 kV	750	200	0.70	1.54
COB20664-1	26.4 kV	750	250	1.30	2.87

C



RM4455-84

RM4455-84

Universal Adapter

It is provided with a thumbscrew to couple to a universal head, allowing the change of the installation angle of a tool.

Approx. Weight: 0.11 kg (0.24 lb)



FLV11623-1

FLV11623-1

Installation Head

An aluminum mounting head, with fiberglass poles, is used with universal adapter for mounting and removal of covers and insulating guards.

Approx. Weight: 0.15 kg (0.33 lb)

PERMANENT COVERS

They are made in rigid black thermoplastic and are resistant to ultraviolet rays and electrical tracking and are suitable for hot-stick and rubber glove hot line use.

Covers for Stirrup Connector

Rated voltage 25 kV (phase/phase)

COB14959-1

For protected distribution line stirrup connectors and clamps.

Approx. Weight: 0.95 kg (2.09 lb)



COB14959-1

Shunt Connector Cover

Rated voltage 14.6 kV (phase/phase)

COB13559-1

For wedge tap connectors on protected distribution lines. Rubber glove work only.

Approx. Weight: 0.10 kg (0.22 lb)



COB13559-1

Transformer Bushing Covers

The bushing cover are used for protection of the transformer terminals on distribution systems, preventing short-circuiting, mainly related to birds and other small animals.

Rated voltage 14.6 kV (phase/phase)

COB11721-1

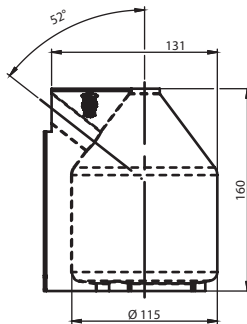

It can be easily installed with specific plastic fasteners, available in one single model for several brands and models of transformers.

Approx. Weight: 0.13 kg (0.29 lb)

COB18644-1

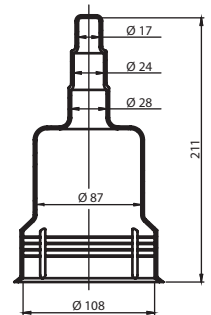

It can be installed on several sizes of cables.

Approx. Weight: 0.11 kg (0.24 lb)

Rated voltage 1 kV (phase/phase)

COB24885-1

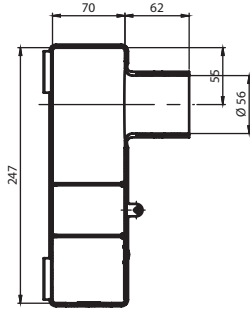

It has a staggered perpendicular output for distribution cables up to \varnothing 21mm, simple installation by predisposed pins.

Approx. Weight: 0.17 kg (0.37 lb)

COB24891-1

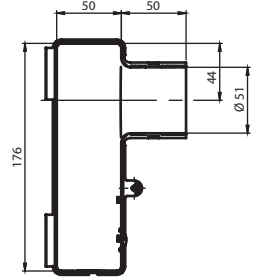

It has a staggered perpendicular output for distribution cables up to \varnothing 18mm, simple installation by predisposed pins.

Approx. Weight: 0.10 kg (0.22 lb)

Rated voltage 25 kV (phase/phase)

COB24863-1

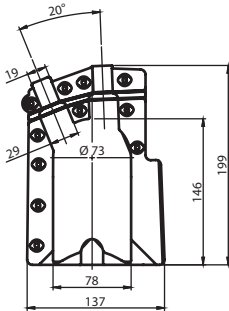

For cables \varnothing 25 mm and \varnothing 15 mm. simple installation by predisposed pins.

Approx. Weight: 0.13 kg (0.29 lb)

Cover for Structure-Mounted Disconnect Base

Rated voltage 14.6 kV (phase/ground)

COB19874-1



It is designed for protection between the disconnect switch housing and energized parts. Permanent use avoids short circuit caused mainly by the contact of birds and other animals.

Approx. Weight: 4.80 kg (10.60 lb)

INSULATED RUBBER BLANKET

Intended for the protection of electricians against accidents by contact at energized points of the structure during maintenance in electrical networks. Due to its flexibility, it allows the covering of irregularly shaped parts such as disconnecting switch, secondary racks, pin insulators, anchor chains, crossings, etc.

Made from special ozone and corona resistant rubber material, orange color, type II (resistant to ozone effects).

Nominal work voltage (phase/phase): 36kV
(Class 4 / Type II / Construction Style A)

Catalog Reference	Description	Approx. Dimensions (mm)	Approx. Thickness (mm)	Approx. Weight	
				kg	lb
LR-4/II	Solid	900 x 900	4.00	4.40	9.70
LR-SP-4/II	Slotted	900 x 900		4.50	9.92
LR-SP-4/II-30396	Slotted	1000 x 1400		4.50	9.92
LR-TP-4/II	Three slot	900 x 1100		5.70	12.60

The Slotted Type has eyelets along its borders, allowing special applications in quite diverse situations through fixing by p lastic button (LIR BLR).

PLASTIC BUTTON*

Catalog Reference	Description
LIR-BLR	Plastic button to fix rubber blankets

* Plastic buttons are not supplied with the blanket, so they must be ordered separately

Cover Pegs

The cover pegs without steel eyes (FLV16886-1) is designed for rubber glove work on blankets and covers.

The cover pegs with steel eyes (FLV16886-2) is designed for hot-stick work on blankets and covers.

Catalog Reference	Description	Length (mm)	Approx. Weight	
			kg	lb
FLV16886-1	Manual plastic peg for rubber glove work	240	0.12	0.26
FLV16886-2	Plastic peg with ring for hot stick work	240	0.16	0.35



LR-4/II



LR-SP-4/II



LR-SP-4 II-30396



LR-TP-4/II

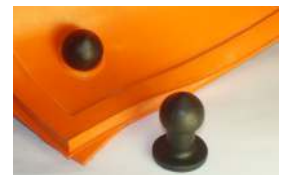

LIR-BLR



FLV16886-1



FLV16886-2

FLEXIBLE COVER FOR CONDUCTORS

Cover for conductors manufactured in orange insulating flexible rubber and in accordance with ASTM D1050 standard requirements. Used as a portable safety device designed to cover exposed energized power lines and to protect electricians from accidental touching and closing circuits during distribution network maintenance.

This cover line has ozone and ultraviolet rays exposure-resistant material (TYPE II), developed for several voltage classes, conductor diameters and lengths.

The cover assembly enjoys the rubber's natural tendency of grabbing and squeezing through compression. The angled end grooves facilitate sliding between covers for installation, but prevent separation during operation. In order to disengage, the operator should only squeeze the rubber on each side.



STYLE A (without nozzle)

Has grooves on its ends for placing and securing nozzles from Style B covers, which aid and ensure the required adherence to prevent sliding during interventions.



STYLE B (with nozzle)

Has grooves on one of its ends and a nozzle on the other for placing and securing, which aid and ensure the required adherence to prevent sliding during interventions.



FLEXIBLE COVER FOR CONDUCTORS - Type II – Style A (without nozzle)

Cat. No.	Type	Nominal Voltage Class	Tension Test Applied	Style	Ø (in)	Length (ft)	Approx. Weight (lb)
FLX30500-1	II	2 (17 kV)	20 kV	A	1"	3	2.27
FLX30500-2	II	2 (17 kV)	20 kV	A	1"	3.5	2.65
FLX30500-3	II	2 (17 kV)	20 kV	A	1"	4.5	3.40
FLX30500-4	II	2 (17 kV)	20 kV	A	1"	5	3.79
FLX30500-5	II	2 (17 kV)	20 kV	A	1"	6	4.54
FLX30500-6	II	2 (17 kV)	20 kV	A	1"	6.5	4.92
FLX30502-1	II	2 (17 kV)	20 kV	A	1.25"	3	2.89
FLX30502-2	II	2 (17 kV)	20 kV	A	1.25"	3.5	4.28
FLX30504-1	II	3 (26.5 kV)	30 kV	A	1.5"	3	3.24
FLX30504-2	II	3 (26.5 kV)	30 kV	A	1.5"	3.5	4.87
FLX30504-3	II	3 (26.5 kV)	30 kV	A	1.5"	5	5.42
FLX30504-4	II	3 (26.5 kV)	30 kV	A	1.5"	6	6.50
FLX30504-5	II	3 (26.5 kV)	30 kV	A	1.5"	6.2	6.72

FLEXIBLE COVER FOR CONDUCTORS - Type II – Style B (with nozzle)

Cat. No.	Type	Nominal Voltage Class	Tension Test Applied	Style	Ø (in)	Length (ft)	Approx. Weight (lb)
FLX30501-1	II	2 (17 kV)	20 kV	B	1"	3	2.93
FLX30501-2	II	2 (17 kV)	20 kV	B	1"	3.5	3.33
FLX30501-3	II	2 (17 kV)	20 kV	B	1"	4.5	4.79
FLX30501-4	II	2 (17 kV)	20 kV	B	1"	5	4.45
FLX30501-5	II	2 (17 kV)	20 kV	B	1"	6	5.23
FLX30501-6	II	2 (17 kV)	20 kV	B	1"	6.5	5.60
FLX30505-1	II	3 (26.5 kV)	30 kV	B	1.5"	3	4.37
FLX30505-2	II	3 (26.5 kV)	30 kV	B	1.5"	4.5	6.0
FLX30505-3	II	3 (26.5 kV)	30 kV	B	1.5"	5	6.55
FLX30505-4	II	3 (26.5 kV)	30 kV	B	1.5"	6	7.63
FLX30505-5	II	3 (26.5 kV)	30 kV	B	1.5"	6.5	7.85

RUBBER INSULATING GLOVES AND SLEEVES

Rubber Insulating Glove

Insulating glove made of natural and synthetic rubber which brings better flexibility in the glove. Type II glove, resistant to ozone and halogenated, thus avoiding the use of talc in its use.

The gloves are designed to protect the electrician's hand, wrist, and forearm against electrical discharges, allowing free movement of the fingers.

RUBBER INSULATING GLOVE

Catalog Reference	Size		Length		Class	Voltage Class (kV)	Adhesive Color	Approval Certificate
	Pol.	mm	Pol.	mm				
RTZ-14-00-8	8	203	14	356	00	0.5	Beige	2.178
RTZ-14-00-8,5	8.5	216						
RTZ-14-00-9	9	229						
RTZ-14-00-9,5	9.5	241						
RTZ-14-00-10	10	254						
RTZ-14-00-10,5	10.5	267						
RTZ-14-00-11	11	279						
RTZ-14-00-11,5	11.5	292						
RTZ-14-00-12	12	303						
RTZ-14-0-8	8	203						
RTZ-14-0-8,5	8.5	216						
RTZ-14-0-9	9	229						
RTZ-14-0-9,5	9.5	241						
RTZ-14-0-10	10	254						
RTZ-14-0-10,5	10.5	267						
RTZ-14-0-11	11	279						
RTZ-14-0-11,5	11.5	292						
RTZ-14-0-12	12	303						
RTZ-14-1-8	8	203	14	356	1	7.5	White	29.774
RTZ-14-1-8,5	8.5	216						
RTZ-14-1-9	9	229						
RTZ-14-1-9,5	9.5	241						
RTZ-14-1-10	10	254						
RTZ-14-1-10,5	10.5	267						
RTZ-14-1-11	11	279						
RTZ-14-1-11,5	11.5	292						
RTZ-14-1-12	12	303						



C

RUBBER INSULATING GLOVE

Catalog Reference	Size		Length		Class	Voltage Class (kV)	Adhesive Color	Approval Certificate
	Pol.	mm	Pol.	mm				
RTZ-14-2-8	8	203	14	356	2	17	Yellow	29.773
RTZ-14-2-8,5	8,5	216						
RTZ-14-2-9	9	229						
RTZ-14-2-9,5	9,5	241						
RTZ-14-2-10	10	254						
RTZ-14-2-10,5	10,5	267						
RTZ-14-2-11	11	279						
RTZ-14-2-11,5	11,5	292						
RTZ-14-2-12	12	303						
RTZ-16-3-8	8	203	16	406	3	26,5	Green	29.772
RTZ-16-3-8,5	8,5	216						
RTZ-16-3-9	9	229						
RTZ-16-3-9,5	9,5	241						
RTZ-16-3-10	10	254						
RTZ-16-3-10,5	10,5	267						
RTZ-16-3-11	11	279						
RTZ-16-3-11,5	11,5	292						
RTZ-16-3-12	12	303						
RTZ-16-4-8	8	203	16	406	4	36	Orange	29.771
RTZ-16-4-8,5	8,5	216						
RTZ-16-4-9	9	229						
RTZ-16-4-9,5	9,5	241						
RTZ-16-4-10	10	254						
RTZ-16-4-10,5	10,5	267						
RTZ-16-4-11	11	279						
RTZ-16-4-11,5	11,5	292						
RTZ-16-4-12	12	303						

C

Rubber Insulating Sleeve

Rubber insulating sleeves are specially produced as electrical insulators for workers in the electrical sector, aiming to protect the arms and forearms.

The sleeves are made of high quality elastomeric compound and mee ASTM D1051/NBR 10623 Standard. They have straps and buttons and are sold in medium and large sizes. Available in black and orange colors.

RUBBER INSULATING SLEEVE

Catalog Reference	Size	Class	Tension Class kV	Adhesive Color	Approval Certificate
RTZ-PR-0-M	Medium	0	1	Black	29.588
RTZ-LA-0-M	Medium	0	1	Orange	37.748
RTZ-PR-1-M	Medium	1	7.5	Black	29.578
RTZ-LA-1-M	Medium	1	7.5	Orange	37.754
RTZ-PR-2-M	Medium	2	17	Black	1.505
RTZ-LA-2-M	Medium	2	17	Orange	25.589
RTZ-PR-2-G	Large	2	17	Black	1.505
RTZ-LA-2-G	Large	2	17	Orange	25.589
RTZ-PR-3-M	Medium	3	26.5	Black	25.589
RTZ-LA-3-M	Medium	3	26.5	Orange	29.573
RTZ-PR-3-G	Large	3	26.5	Black	29.589
RTZ-LA-3-G	Large	3	26.5	Orange	29.573
RTZ-PR-4-M	Medium	4	36	Black	33.400
RTZ-LA-4-M	Medium	4	36	Orange	35.724
RTZ-PR-4-G	Large	4	36	Black	33.400
RTZ-LA-4-G	Large	4	36	Orange	35.724



REMOVABLE PROTECTIVE COVER

Designed to protect energized circuits up to 38 kV phase/phase, avoiding phase-to-phase or phase-to-ground contact, which can be accidentally caused by animals, generating possible shutdowns.

They are made of flexible plastic and specially molded on demand for the most different types and application conditions, such as: connector, splice, bus, and bushing in medium voltage structures. It can be quickly installed on these components and fastened with nylon clips.

These covers are fully reusable and can be removed and reinstalled for inspections in structural components.



C

GROUP D



Access our site.



TOOL REPAIR AND STORAGE



Repair Sets and Lubricants.....	139
Storage	141
Tool Trailer	146

TOOL REPAIR AND STORAGE



REPAIR SETS AND LUBRICANTS

Before purchasing these restorers and lubricants, we recommend that you obtain from our sales department basic information on their applications and export policy for chemical products.

These products can be easily applied by the user.

RT400-0803

Gloss Restorer

Is a colorless resin specially prepared for surface restorations in RITZGLAS® poles when they present surface wear and loss of gloss.

These types of damage on insulated poles compromise their dielectric strength, caused by moisture and impurity contamination.

Supplied with ten 100 ml bottles, being five units of component A and five of component B, packed in a plastic case

Approx. Weight: 2.60 kg (5.37 lb)



RT400-0803



RM1909

RM1909

Tool Lubricant

Made of non-toxic and non-corrosive materials. It has high lubricating power, preventing oxidation through a durable film, avoiding friction and wear of metal tools.

Approx. Weight: 2.10 kg (4.63 lb)



RH1917

RH1917

Bond Patching

Set is an orange resin and hardener set recommended only for recovering from minor cracks or other surface damage such as tears or splits caused by accidental or improper use of the equipment, and to reposition metal heads in poles.

Supplied in two 100 ml bottles, components A and B

Approx. Weight: 0.32 kg (0.71 lb)



RM1904

RM1904

Silicone-soaked hot stick wiping cloth for surface treatment

Cloth measuring 500 x 500 mm. Soaked with silicone and designed for surface applications on the pole for preventive protection, leaving a protective layer in its surface.

Approx. Weight: 0.08 kg (0.18 lb)

STORAGE

Bucket Tote Bag

Tote bag made of durable and waterproof canvas with bottom reinforced by thermoplastic material. Strap of polypropylene rope, fixed at its edge through metal eyelets, which accompanies carabiner to enable its removal. Excellent stitching and finishing.

FLV16364-1

The bag is used for transportation and storage of ropes used in hot line interventions, to avoid contamination and easy handling.

Ø 300 mm x 400 mm deep

Approx. Weight: 1,90 kg (4,19 lb)

Useful in packaging, transport and especially in the hoisting of live line tools in the work structure, providing protection and safety in moving them.

RC417-0144

Ø 305 mm x 380 mm deep

Approx. Weight: 0,49 kg (1,10 lb)

RC417-0146

Ø 180 mm x 255 mm deep

Approx. Weight: 0,27 kg (0,60 lb)



FLV16364-1



RC417-0144

Transportation Bags

Due to their small weight, waterproof bags become practical and safe when transporting the grounding sets. Reinforced material, with fiberglass bottom, suitable for cable and hardware storage.



ATR09962-1

ATR09962-1

Dimensions: 290 mm (A) x 240 mm (L) x 645 mm (C)

Volume: 0.04 m³



ATR14484-2

ATR14484-1

Dimensions: 330 mm (A) x 240 mm (L) x 300 mm (C)

Volume: 0.02 m³

ATR14484-2

Dimensions: 420 mm (A) x 270 mm (L) x 400 mm (C)

Volume: 0.04 m³

Bag Type

Made of reinforced material, suitable for cables and fittings.



ATR16843

Catalog Reference	Dimensions (mm)			Volume (m ³)
	A	L	C	
ATR16843-1*	250	340	1350	0.11
ATR16843-2*	250	340	1550	0.13
ATR16843-3*	180	210	1550	0.06
ATR16843-4*	280	240	1100	0.07
ATR16843-5	200	240	900	0.04
ATR16843-6	150	200	800	0.03
ATR16843-7	150	200	550	0.02

* They have an internal division to store the grounding rod

Bag for Telescopic Hot Sticks (VTT)

Useful in packing and transporting the telescopic hot sticks, according to their appropriate size, providing protection and safety of tools.

Made of water-resistant green canvas. Reinforced synthetic leather strap with double layer. Has a pocket for carrying the heads. Excellent stitching and finishing.

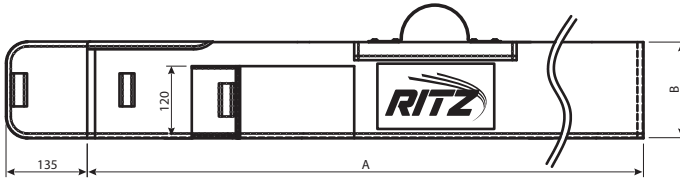

Catalog Reference	Dimensions (m)	
	A	B
SLT-2/3	1.55	0.12
SLT-4/5	1.66	0.14
SLT-6/7	1.75	0.16
SLT-8/9	1.86	0.18
VTT17182-5	1.97	0.20
VTT17182-6	2.08	0.22
VTT17182-7	2.19	0.22

Bag for Sectional Hot Sticks (VMR)

Has reinforced edges, internal dividers for the proper storage of hot stick sections, a carrying handle, and an additional pocket for a tool head.

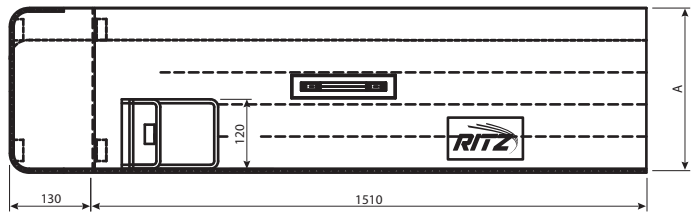

Catalog Reference	Rod	Internal Dividers		Dimensions (m)	
		Rod	VMR	Length	Width (A)
VMR10484-1	ATR00137-1	1	3	1.51	0.38
VMR10484-2	ATR00137-2	1	3	1.51	0.38
VMR10484-3	-	-	3	1.51	0.26
VMR16824-1	-	-	1	1.51	0.11
VMR16824-2	-	-	2	1.51	0.19
VMR16825-1	-	-	4	1.51	0.34
VMR16825-2	ATR00137-2	1	4	1.51	0.42
VMR16826-1	-	-	5	1.51	0.42

Bag for Sticks

Useful in packing and transporting various types of sticks, according to their appropriate size, providing protection and safety of tools.

Made of water-resistant green canvas. Reinforced synthetic leather strap with double layer. Excellent stitching and finishing.

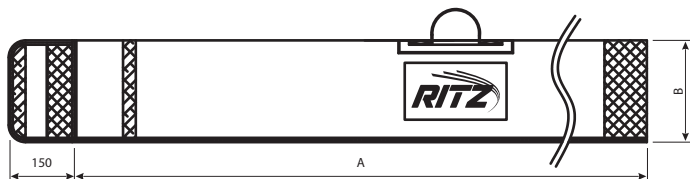

Catalog Reference	Dimensions (m)	
	A	B
FLV18339-1	1.49	0.17
FLV18339-2	2.10	0.17
FLV18339-3	2.71	0.17
FLV18339-4	3.32	0.17
FLV18339-5	4.00	0.17
FLV18339-6	1.20	0.34
FLV18339-7	1.50	0.34
FLV18339-8	1.75	0.34
FLV18339-9	2.10	0.34
FLV18339-10	2.40	0.34
FLV18339-11	2.70	0.34
FLV18339-12	1.70	0.17
FLV18339-13	2.40	0.17
FLV18339-14	4.60	0.17
FLV18339-15	1.00	0.17
FLV18339-16	5.10	0.17
FLV18339-17	6.10	0.17

TOOL TRAILER



FLV03102-1

Hot line tool storage and transport trailer

Rated Work Capacity: 1500 kg (3306 lb)

Approx. Weight: 1420 kg (3130 lb)



TECHNICAL CHARACTERISTICS

- Chassis structure in steel profiles;
- Wheel set: 16" rim (215 x 80 x16 tires);
- Suspension type;
Leaf spring assembly and telescopic shock absorbers;
- Tandem axle suspension and lubricated balance system;
- Rear cover lifting system;
Pantograph type, crank screw drive;
- 4 ton overrun brake assembly;
- Jockey wheel suspension for 120 kg (265 lb);
- Supplied with wheel wrench and spare wheel;
- Ball-and-shell trailer coupling;
- Electrical supply between tow truck and trailer; electric harness with a 7-pole 12V outlet;
- Internal heating system;
Bi-volt cooler with selector switch (110 or 220 Volts);
Cooler is powered by a harness (when parked)
- Rubber lined ladder holders mounted on the rear cover.



Tool storage rack



Jockey wheel



Electric whip



Power plug



Climatizer

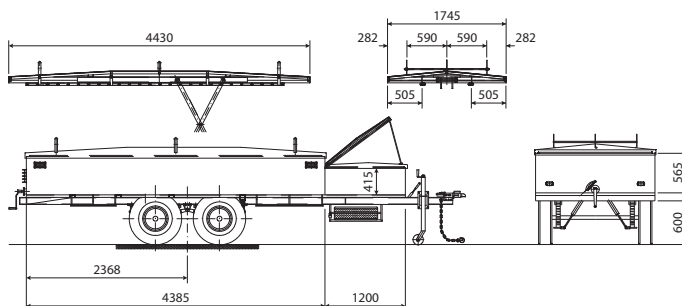

NOTE

Adapt the trailer to a vehicle with a towing capacity of at least 3 ton.

GROUP E



Access our site.



LADDERS, PLATFORMS AND INSULATING SCAFFOLD



“U”- Shape Side-rails.....	149	Ladder with Double siderail	161
Oblong-Shape Side-rails.....	151	Insulating Spacer for Ladders.....	162
“A” Shape Ladders	152	Platform	163
Mobile Tower Type Ladder.....	153	Insulating Stool	165
Hot Line Ladder	154	Insulating Modular Scaffold	166
Accessories for Ladder Support.....	158	Insulating Scaffold Equalization and Grounding Kit	175
Adjustable Ladder Hooks	160		

GROUP E

LADDERS, PLATFORMS AND INSULATING SCAFFOLD



Ritz ladders are extremely sturdy and durable. They can be used indefinitely (as long as the care and conservation procedures in the manual are observed) and are portable, allowing manual transport.

Their type and size are suitable for the tasks at hand and are in good use and conservation conditions for safe and highly productive work.

“U”- SHAPE SIDE-RAILS

Single and extension ladder with U-shape fiberglass side-rails, round aluminum rungs, non-slip grooves with nylon strap and rubber shoe, meeting category IA of ANSI A14.5.

Resistant to weather and ultraviolet, it has safety strips in yellow and black.

These ladders are intended for maintenance in de-energized structures or up to 15 kV by the distance work method (using insulating poles).

Nominal Working Capacity: 136 daN (300 lb)



“U”- shape

E



SINGLE LADDER

Catalog Reference	Nominal Length (m)		Qty. of Rungs	Approx. Weight	
	kg	lb		kg	lb
ES/PU-29-CN-SB	3.09		9	9.20	20.28
ES/PU-32-CN-SB	3.39		10	10.10	22.27
ES/PU-35-CN-SB	3.69		11	11.00	24.25
ES/PU-38-CN-SB	4.00		12	11.90	26.24
ES/PU-41-CN-SB	4.29		13	12.80	28.22
ES/PU-44-CN-SB	4.59		14	13.70	30.20
ES/PU-47-CN-SB	4.89		15	14.60	32.19
ES/PU-50-CN-SB	5.20		16	15.50	34.17
ES/PU-53-CN-SB	5.49		17	16.40	36.16
ES/PU-56-CN-SB	5.80		18	17.30	38.14
ES/PU-59-CN-SB	6.10		19	18.20	40.12
ES/PU-62-CN-SB	6.40		20	19.10	42.11
ES/PU-65-CN-SB	6.69		21	20.00	44.09

Inner width between siderails: 320 mm

Distance between rungs: 300 mm



EXTENSION LADDER

Catalog Reference	Nominal Length (m)		Qty. of Rungs	Approx. Weight	
	Retracted	Extended		kg	lb
EE/PU-35-CN-SB	2,68	3,67	11	16,00	35,27
EE/PU-41-CN-SB	2,96	4,27	13	17,70	39,02
EE/PU-47-CN-SB	3,28	4,87	15	18,50	40,79
EE/PU-53-CN-SB	3,68	5,47	17	21,20	46,74
EE/PU-59-CN-SB	3,99	6,08	19	23,00	50,71
EE/PU-65-CN-SB	4,28	6,68	21	24,80	54,67
EE/PU-71-CN-SB	4,58	7,27	23	26,50	58,42
EE/PU-77-CN-SB	4,87	7,87	25	28,30	62,39
EE/PU-84-CN-SB	5,17	8,46	27	30,00	66,14
EE/PU-90-CN-SB	5,40	9,07	29	31,70	69,89
EE/PU-97-CN-SB	6,09	9,97	33	34,00	74,96

Width between side rails: Top Section - 293 mm

Bottom Section - 320 mm

Distance between rungs: 300 mm

OBLONG-SHAPE SIDE-RAILS

Single and extension ladders, with side-rails (oblong shape) and rungs (round, non-slip), made of RITZGLAS® tubes. They are finished in polyurethane painting and equipped with a rubber-coated nylon support band, movable or fixed shoes with non-slip rubber, meeting category IA of ANSI A14.5.

Extendable models feature nylon pulleys (for smooth sliding of its parts), metal rings on base rungs, steel ratchets and plastic-coated side guides.

These ladders are intended for maintenance in de-energized structures, or up to 15 kV, using the distance work method (using insulated poles).

For maintenance up to 15 kV (using the contact method) we recommend the Double Stringer Ladders with Insulated Ladder Spacer FLV14717-1 (see specific page).

Nominal Working Capacity: 136 daN (300 lb)



Oblong-shape



SINGLE LADDER

Catalog Reference	Nominal Length (m)	Qty. of Rungs	Approx. Weight	
			kg	lb
ES/PR-8/27-CN-SM	2.78	8	11.00	24.25
ES/PR-8/40-CN-SM	4.03	12	15.52	34.21
ES/PR-8/46-CN-SM	4.65	14	17.78	39.20
ES/PR-8/58-CN-SM	5.84	18	22.30	49.16

Inner width between siderails: 305 mm

Distance between rungs: 305 mm

EXTENSION LADDER

Catalog Reference	Nominal Length (m)		Qty. of Rungs	Approx. Weight	
	Retracted	Extended		kg	lb
EE/PR-12/58-CN-SM	3.45	5.86	19	30.00	66.13
EE/PR-12/70-CN-SM	4.05	7.08	23	35.50	78.26
EE/PR-12/82-CN-SM	4.64	8.28	27	39.00	86.00
EE/PR-15/95-CN-SM	5.25	9.52	31	50.00	110.23
EE/PR-15/10-CN-SM	6.28	10.76	35	54.00	119.00
EE/PR-15/11-CN-SM	6.88	11.98	39	61.00	134.48
EE/PR-15/14-CN-SM *	7.80	13.84	45	67.00	147.71

* It must be supported when used through eyebolts on the last rung of the fixed part (base).

Width between side rails: Top Section - 365 mm

Bottom Section - 305 mm

Distance between rungs: 305 mm

“A” SHAPE LADDERS

Designed for maintenance on de-energized structures. It consists of hinged segments at the upper end, with opening limiter. It has a top board for tools and other objects.

Nominal Working Capacity: 136 daN (300 lb)

For step ladders (heavy category) supplied with Ø 3/8" fiberglass rods at the center of its rungs, the "TR" suffix must be added to its reference code.

Example: EA/PR-21/PD/TR

Double

With rungs on both sides.



Catalog Reference	Rated Length (m)				Qty. of Rungs on each side	Approx. Weight	
	A	B	C	D		kg	lb
EA/PR-12/PD	1.22	0.55	0.93	0.42 x 0.25	03	15.10	32.29
EA/PR-15/PD	1.51	0.58	1.16	0.42 x 0.25	04	18.60	41.00
EA/PR-21/PD	2.13	0.62	1.30	0.42 x 0.25	06	25.50	56.22
EA/PR-27/PD	2.73	0.71	1.80	0.42 x 0.25	08	32.70	72.09
EA/PR-34/PD	3.35	0.78	2.12	0.42 x 0.25	10	40.30	88.84
EA/PR-40/PD	3.96	0.85	2.37	0.42 x 0.25	12	48.00	105.82
EA/PR-52/PD	5.17	0.97	3.07	0.42 x 0.25	16	64.30	141.76

Distance between rungs 305 mm

MOBILE TOWER TYPE LADDER

It provides a condition of access and positioning of the electrician at necessary heights for carrying out the most diverse types of maintenance work in electrical systems (substations and industries).

Made of RITZGLAS®, with a 600 mm x 600 mm platform and a 200 mm high baseboard. Distance between steps of 210 mm with non-slip tape. It has 6" casters and polyurethane paint finish to ensure external use. Its binding elements are manufactured in thermally treated cast aluminum alloy that allow disassembly for displacement and storage.

Nominal Working Capacity: 136 daN (300 lb)



Catalog Reference	Nominal Length (mm)			Qty of Rungs	Approx. Weight	
	A	B	C		kg	lb
ETM/01	420	1680	832	01	29.10	64.15
ETM/02	630	1890	953	02	33.00	72.75
ETM/03	840	2100	1074	03	36.80	81.10
ETM/04	1050	2310	1195	04	40.70	89.70
ETM/05	1260	2520	1316	05	44.60	98.30
ETM/06	1470	2730	1437	06	48.50	106.90
ETM/07	1680	2940	1558	07	52.40	115.50
ETM/08	1890	3150	1679	08	56.20	123.90
ETM/09	2100	3360	1800	09	60.10	132.50
ETM/10	2310	3570	1921	10	64.00	141.10
ETM/11	2520	3780	2042	11	67.80	149.50
ETM/12	2730	3990	2163	12	71.70	158.10
ETM/13	2940	4200	2284	13	75.60	166.70
ETM/14	3150	4410	2405	14	79.50	175.30

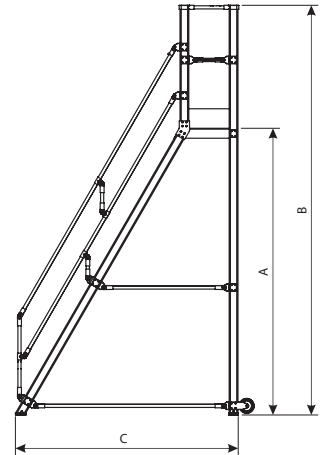

E

HOT LINE LADDER

Hot line ladders have many applications in high voltage energized interventions, as they allow electricians to work in a convenient position and perform line repairs in almost inaccessible locations.

All hooks in these ladders are made of surface-treated steel, with $\varnothing 25.4$ mm (1"), and swivel to adapt to many positions on the structure.

For increased operational safety, the hooks features a surface-treated steel chain and locking device.

The rungs in these ladders are made of $\varnothing 32$ mm RITZGLAS® tubes with non-slip coating.

Besides the excellent bonding process between rails and rungs, the ladder have steel rods installed near the ends.

Single Ladders with Hook

RH4903-8 to RH4903-12 series ladders are made of $\varnothing 38$ mm RITZGLAS® tubes. RH4904-8 to RH4904-16 series ladders are built with $\varnothing 51$ mm RITZGLAS® tubes, which make up their rails. All of them are used exclusively for vertical work.

The ladders (RH4905-8 to RH4905-20 series) are made of $\varnothing 64$ mm RITZGLAS® poles, which make up their rails, preferably used for horizontal work.



LADDERS WITH Ø 38 mm SIDERAILS

Catalog Reference (8" Hook)	Insulation Length (m)	Distance between Rungs (m)	Storage (optional)	Approx. Weight	
				kg	lb
RH4903-8	2.39	0.30	FLV22117-1	11.00	24.25
RH4903-10	3.00		FLV22117-2	12.90	28.44
RH4903-12	3.61		FLV22117-3	14.90	32.85

LADDERS WITH Ø 51 mm SIDERAILS

Catalog Reference (8" Hook)	Insulation Length (m)	Distance between Rungs (m)	Storage (optional)	Approx. Weight	
				kg	lb
RH4904-8	2.39	0.30	FLV22117-1	20.80	45.86
RH4904-10	3.00		FLV22117-2	22.90	50.49
RH4904-12	3.61		FLV22117-3	24.40	53.79
RH4904-14	4.22		FLV22117-4	26.20	57.76
RH4904-16	4.83		FLV22117-5	28.60	63.05

LADDERS WITH Ø 64 mm SIDERAILS

Catalog Reference (8" Hook)	Insulation Length (m)	Distance between Rungs (m)	Storage (optional)	Approx. Weight	
				kg	lb
RH4905-8	2.39	0.30	FLV22117-1	28.60	63.05
RH4905-10	3.00		FLV22117-2	31.00	68.34
RH4905-12	3.61		FLV22117-3	33.00	72.75
RH4905-14	4.22		FLV22117-4	37.20	82.01
RH4905-16	4.83		FLV22117-5	38.70	85.32
RH4905-18	5.44		FLV22117-6	42.00	92.59
RH4905-20	6.05		FLV22117-7	43.40	95.68

Rated working capacity:

Ladders with 8" hooks (0.20 m): 567 daN (1250) lb.



E

Sectional Ladders with Hooks



They are made with Ø 64 mm RITZGLAS® tubes, which make up their siderails and allow length combinations up to 9.76 m.

All sections are interchangeable to reach different heights with a few sections. Their lengths are suitable for transportation.

The top sections have steel hooks, and sections are connected with steel sleeves (with surface treatment and copper alloy cotter pins) for perfect locking.

Designed and manufactured in accordance with the IEC 61478 standard.

TOP SECTION Ø 64 mm

Catalog Reference (8" Hook)	Insulating Length (m)	Storage (optional)	Approx. Weight	
			kg	lb
RC402-0482	3.00	FLV22117-2	30.60	67.46
RC402-0402	3.61	FLV22117-3	33.00	72.75
RC402-0404	4.22	FLV22117-4	35.40	78.04
RC402-0407	4.83	FLV22117-5	37.80	83.33
RC402-0411	6.05	FLV22117-7	42.60	93.92

MIDDLE SECTION Ø 64 mm

Catalog Reference (8" Hook)	Insulating Length (m)	Storage (optional)	Approx. Weight	
			kg	lb
RT402-0423	2.96	FLV22117-2	22.00	48.50

BOTTOM SECTION Ø 64 mm

Catalog Reference (8" Hook)	Insulating Length (m)	Storage (optional)	Approx. Weight	
			kg	lb
RC402-0418	2.39	FLV22117-8	19.60	43.21
RC402-0421	3.00	FLV22117-2	22.00	48.50
RC402-0422	3.61	FLV22117-3	24.40	53.79

One-Siderail Sectional Ladder

It is designed for vertical work so electricians can access conductors in de-energized suspension chains without the need to support the chain itself. This avoids possible insulator breakage accidents.

It is made with a Ø 51 mm RITZGLAS® tube, which makes up its center rail, and Ø 32 mm RITZGLAS® tube rungs.

All sections are interchangeable so different heights can be reached with the 3 sections. Their lengths are suitable for transportation.

The upper section has 14" rotating steel hooks and sections are connected with steel sleeves (with surface treatment and bronze cotter pins) for perfect locking.

All sections have a storage and transportation bag.

Catalog Reference	Insulating Length (m)	Section	Storage Bag	Capacity Rated Approx.		Approx. Weight	
				daN	lb	kg	lb
FLV18198-1	1.45	Upper	FLV18232-1			9.30	20.50
FLV18199-1	2.32	Intermediary	FLV18232-2	120	265	8.60	18.96
FLV18200-1	2.24	Base	FVL18232-2			8.75	19.29

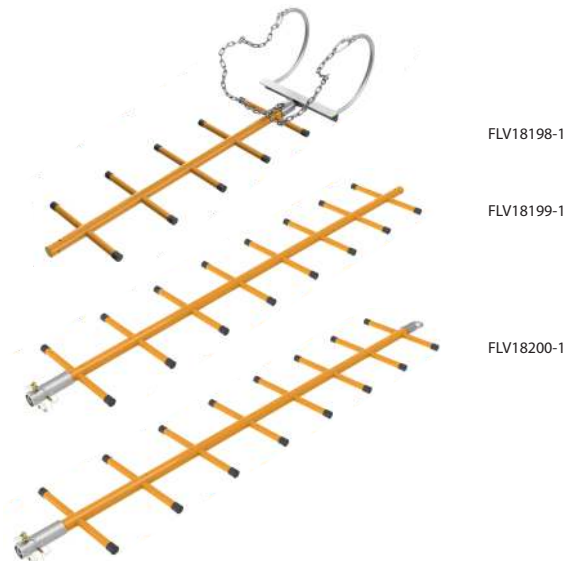

ACCESSORIES FOR LADDER SUPPORT

The ladder support set is designed for quick, easy, and safe mounting of an energized work ladder in almost every type of structure.

They are designed to be coupled to metal, wood, or concrete structures, in vertical or horizontal positions, with Ø 64 mm rail or higher.

Components can be purchased separately or as replacement parts.

The diagram below shows a typical installation and workloads with different anchor points.

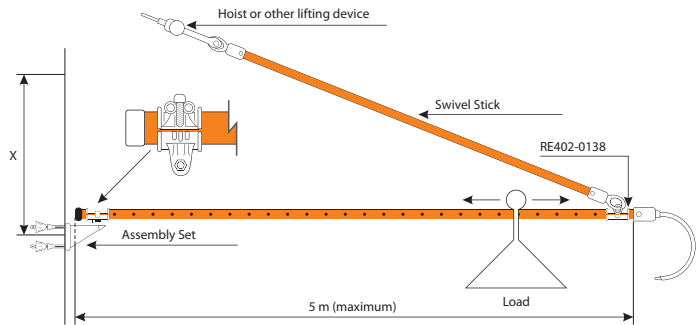

"X" = Distance between mounting points (m)	Maximum total workload		Ladder Total Length (m)
	kg	lb	
2.44	227	500	4.88
3.66	182	400	7.32
4.88	132	290	9.75

NOTE

For assemblies requiring ladders higher than 5 m, an additional support set must be installed.

SET FOR VERTICAL ASSEMBLY ON METALLIC STRUCTURE

Catalog Reference	Composition of the Set						Approx. Weight	
	RE402-0525	RE402-0092*	RE402-0099	RE402-0138	RE402-0141*	RE402-0568	kg	lb
	RC402-0139	1	1	1	2	2	1	27.64

* See other models.



RE402-0525



RE402-0087



RE402-0526

SET FOR HORIZONTAL ASSEMBLY ON METALLIC STRUCTURE

Catalog Reference	Composition of the Set						Approx. Weight	
	RE402-0087	RE402-0092*	RE402-0099	RE402-0138	RE402-0141*	RE402-0568	kg	lb
	RC402-0140	1	1	1	2	2	1	27.89

* See other models.

COMPONENTS TO SUPPORT THE LADDERS

Catalog Reference	Description	Approx. Weight	
		kg	lb
RE402-0525	Saddle for vertical attachment on metallic structure	11.25	24.80
RE402-0087	Saddle for horizontal attachment on metallic structure	11.50	25.35
RE402-0526	Base of the vertical pole attachment saddle	11.09	26.21
FLV31089-1	Saddle for fixing on double T concrete pole	5.60	12.34
RE402-0099	Spreader Bar	3.80	8.38
RE402-0138	Ø 64 mm clamp for rod	0.79	1.74
RE402-0568	Ladder support with 64 mm clamp	6.60	14.55
RE402-0569	Ladder support with 51 mm clamp	6.50	14.33

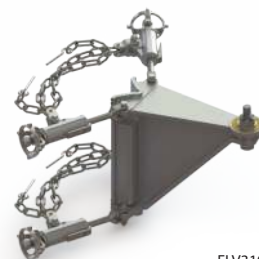

FLV31089-1



RE402-0099



RE402-0138



RE402-0568



DOUBLE CLAMP

Catalog Reference	Ø (mm)	Approx. Weight	
		kg	lb
RE402-0092	64 / 38	1.30	2.87
FLV03550-2	64 / 32	1.20	2.65
FLV03550-6	64 / 76	1.50	3.31
FLV03550-7	38 / 51	1.35	2.98



Ø 32 mm SWIVEL STICK

Catalog Reference	Insulating Length (mm)	Rated Work Capacity		Approx. Weight	
		daN	lb	kg	lb
RE402-0141	3512	1588	3500	3.90	8.60
RT402-0899	1712			1.90	4.19
RT402-0900	2312			2.50	5.51
RT402-0901	2912			3.20	7.05

ADJUSTABLE LADDER HOOKS

It is easily adapted to the rail of the hot line ladder and platform ladder.

This installation can be used to convert a ladder with Ø 51 or 64 mm rails into a hooked ladder or to mount ladders on tilted structures.

The hooks are easily mounted with their clamps and can freely rotate, allowing them to be placed in the most convenient position on the structure.

Constructed of galvanized steel, with Ø 25.4 mm (1") and mounted on an aluminum collar clamp. Complementary hook steel chains have a safety locking device.



Catalog Reference			Ø Side Rails (mm)	Rated Working Capacity per pair		Approx. Weight	
8" hook (203 mm)	14" hook (356 mm)	18" hook (457 mm)		daN	lb	kg	lb
RH4904-1	-	-	51	567	1250	4.70	10.36
-	RH4924-1	-		454	1000	5.60	12.35
RH4905-1	-	-	64	567	1250	4.80	10.58
-	RH4925-1	-		454	1000	5.70	12.57
-	-	RH4945-1		340	750	6.60	14.55

LADDER WITH DOUBLE SIDERAIL

It made of RITZGLAS® tubes and designs for hot line work, in installations up to 500 kV.

The single and extension ladders are fitted with a rubber-coated nylon strap and fixed rubber shoes.

Trapezoidal ladders are equipped with aluminum terminals and 8" hooks for overhead work. They should not be used horizontally.

All ladders are supplied with transport and storage bags.

NOTES

- Extension ladders must be braced through its eye bolts mounted at the top of the base element.
- Required bending tests must be performed with a maximum length of 8.50 meters.



SINGLE LADDER

Catalog Reference	Rated Length (m)	Qty. of Rungs	Approx. Weight	
			kg	lb
ES/LV-28-CN-SB	2.80	8	11.00	24.25
ES/LV-37-CN-SB	3.70	11	14.00	30.86
ES/LV-46-CN-SB	4.60	14	20.00	44.09
ES/LV-59-CN-SB	5.90	18	21.00	46.30

Width between siderails: 293 mm.
Distance between rungs: 305 mm.

EXTENSION LADDER

Catalog Reference	Rated Length (m)		Qty. of Rungs	Approx. Weight	
	Retracted	Extended		kg	lb
EE/LV-96-CN-SB	5.32	9.14	29	45.50	100.31
EE/LV-108-CN-SB	5.93	10.36	33	49.50	109.13
EE/LV-120-CN-SB	6.84	12.19	39	53.50	117.95

Width between siderails: Base - 93 mm.
Tip - 295 mm.
Distance between rungs: 305 mm.





TRAPEZE LADDER WITH 8" HOOKS TO SUSPENSION

Catalog Reference	Rated Length (m)	No. of Rungs	Approx. Weight	
			kg	lb
ET/LV-28	2.80	9	22.60	49.80
ET/LV-37	3.70	12	25.30	55.70
ET/LV-46	4.60	15	27.00	59.50
ET/LV-59	5.90	19	30.00	66.10

Width between siderails: 365 mm.
Distance between rungs: 305 mm.

INSULATING SPACER FOR LADDERS

FLV30595-1

It is intended to move the insulating ladder away from the posts in live line activities. As an alternative for performing live online activities, where there is no access to vehicles with an aerial basket.

It has a regulating pin allowing the equipment to have a 180 ° rotation of the tip in relation to the body and a bronze "T" screw that ensures the tightness and safety of the equipment at the desired angle. The equipment maintains the distance from the stairs to the pole, bringing a significant gain in safety and ergonomics, when compared to the current methodology of stairs supported directly on the poles.

Lating length: 700 mm

Nominal load capacity: 136 kg (300 lbf)

Approx. Weight: 23.25 kg (51.26 lb)



E

PLATFORM

They are designed with RITZGLAS® tubes to provide the electrician with a safe and convenient base for rubber glove and hot-stick work.

It can be quickly mounted to structures so that the electrician is vertically and horizontally well positioned.

These platforms quickly mount to the structure using two options:

- Fixed mount

For works that do not require frequent platform side position changes. The platform is fixed to the pole with the chain stretcher or to the structure through jaws.

- Pivot type

It allows the electrician to rotate 180° horizontally on the mounted platform and position it at left or right intermediate angles.

The board is 250 mm wide and is made of fiberglass, with non-slip floor surface, preventing accidental slips.

Its handrail and tripod are a support and mounting point for the safety belt fall arrest device.

Designed for pole mounting. To be mounted on metal structures, it must be fitted with its exclusive saddles, as shown in the platform accessory tables.

Insulating Platform

It includes a 0.30 m insulation between the board and the pole-mounted saddle through two Ø 51 mm RITZGLAS® tubes, so the insulating platforms can be used in rubber glove and hot-stick operations in energized lines up to 34.5 kV.

Rated working capacity: 227 daN (500 lb).

Catalog Reference	Description	Approx. Weight	
		kg	lb
FLV17436-1	Insulating platform (1.80 m) with pivot saddle and handrail	39.80	87.74



E

Aerial Platforms

It is designed for work in hot-stick work.

Rated working capacity: 227 daN (500 lb).



Catalog Reference	Description	Approx. Weight	
		kg	lb
RH4964-6W	Aerial platforms (1.80 m) with fixed pole mount and handrail	34.60	76.28

Suspension Platform

It allows 180° rotation in the horizontal plane, so electrician can better position the platform without disassembling for further adjustments. It is commonly used in structures with reduced space where a conventional platform cannot be mounted.

Rated working capacity is 181 daN (400 lb) in aligned position and perpendicular to the structure. Capacity is reduced to 136 daN (300 lb) when positioned at any different angle.



Catalog Reference	Description	Approx. Weight	
		kg	lb
RT402-0030	Suspension platform (1.20 m) with pivot saddle and tripod	28.10	61.95

Platform Saddle

Designed for situations where the electrician needs a footrest on the pole for height-limited ladders.

Made of aluminum alloy and adjusted to the pole with a chain stretcher for final tightening.

Rated working capacity: 340 daN (750 lb).



Catalog Reference	Description	Approx. Weight	
		kg	lb
FLV06423-1	Footrest platform saddle	3.40	7.50

NOTE

Due to their constructive characteristics, the utility platform and the saddle platform are not insulating.

Ladder Platform

It allows the electrician to work from a standing or sitting position, for better positioning on the structure.

It consists of a 1.20 m RITZGLAS® ladder and a fiberglass platform with a 0.25 x 0.51 m non-slip surface. When provided with adjustable hooks, they are used to be mounted to the structure.

This platform can be folded for easy transport and storage.

Rated working capacity: 227 daN (500 lb).

Catalog Reference	Description	Approx. Weight	
		kg	lb
RC402-0277	Platform ladder with suspension hook	28.50	62.83



INSULATING STOOL

An equipment that helps the electrician in insulating from ground potential, as it extends the electrician's work area and safety in interventions in substations, switchgears, electrical panels.

- Made of polyethylene;
- Reduced weight providing greater transportation and handling comfort;
- Non-slip surface floor;
- Rated working capacity: 120 daN (265 lb);
- Orange color.

Catalog Reference	Size (m)		Rated Working Voltage (kV)	Approx. Weight	
	Non-slip Floor	Height		kg	lb
FLV21504-1	0.50 x 0.50	0.32	40	4.05	8.93



E

INSULATING MODULAR SCAFFOLD

Equipment required for interventions in high and extra-high voltage electrical installations, mainly substations.

It provides a condition of access and positioning to the electrician at heights necessary for the most diverse types of bare-hand and hot-stick works. The development of new components has greatly expanded the mounting options for the insulating scaffold. It also allowed compliance with the NR-18 standard requirements (brazilian standard).

Made of lightweight, interchangeable, snap-on parts, assembly is easy, simple, and quick. It can also be performed by only two electricians, without requiring additional tools.

Its structure is made with RITZGLAS® tubes, with electrical and mechanical properties in accordance with the IEC-60855 and ASTM F 711 standards. So it can be used in energized installations up to 800 kV, ensuring full electrical insulation and a rated working capacity of up to 300 daN (660 lb) at the center of the platform.



RITZGLAS® INSULATING SCAFFOLDS - ASSEMBLING OPTIONS

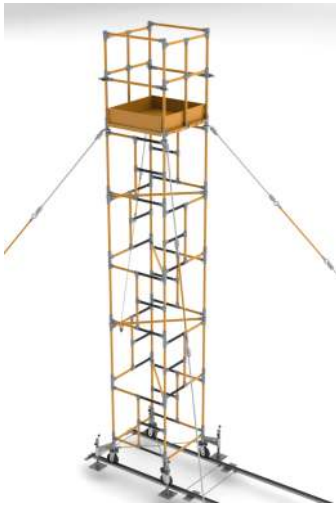

01 Base, Column, and Platform:
1.0 x 1.0 m

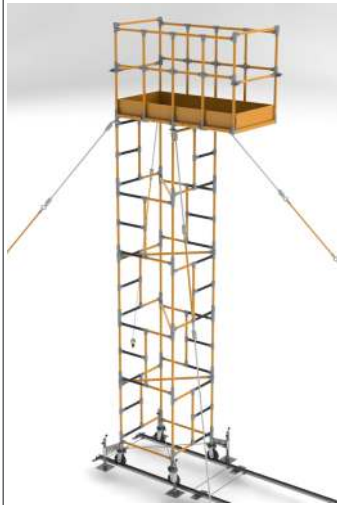

02 Base and Column: 1.0 x 1.0 m
Platform: 2.0 x 1.0 m



03 Base and Column: 1.0 x 1.0 m
Two Platforms: 2.0 x 1.0 m
Side Extension: 1.0 m

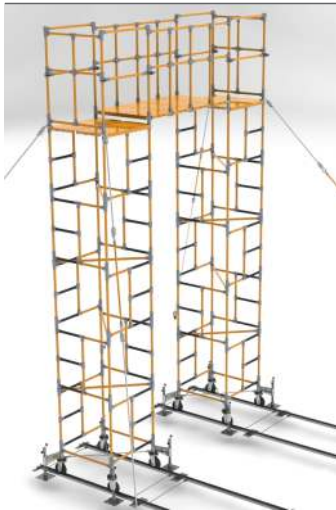

04 Two Columns: 1.0 x 1.0 m
Platform: 4.0 x 1.0 m

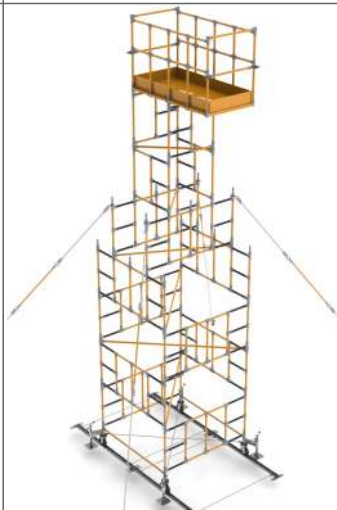

05 Base and Column: 2.0 x 2.0 m
Reduced to: 1.0 x 1.0 m
Platform: 2.0 x 1.0 m
Side Extension: 1.0 m



06 Base, Column, and Platform: 2.0 x 2.0 m

MAIN COMPONENT

Catalog Reference	Description	Approx. Weight	
		kg	lb
FLV06052-1	1.0 x 1.0 m module with cast aluminum connection made of Ø 38 mm RITZGLAS® tubes. It has non-slip rungs and locking cotter pins	7.00	15.43
FLV09091-1	1.0 x 2.0 m module with cast aluminum connection made of Ø 38 mm RITZGLAS® tubes. It has non-slip rungs and locking cotter pins	12.20	26.90
FLV13916-1	1.0 x 2.0 m module with cast aluminum connection made of Ø 38 mm RITZGLAS® tubes. It has non-slip rungs, locking cotter pins and 5 upper pins for mounting in unconventional arrangements.	13.60	29.98
FLV16241-1	Side crosspiece made with RITZGLAS® tube Ø 38 mm x 1.0 m and cast aluminum plug heads for lateral closing and locking of the modules in the 1.0 x 1.0 m base scaffolding assemblies	0.89	1.96
FLV16241-2	Side crosspiece made with RITZGLAS® tube Ø 38 mm x 2.0 m and cast aluminum plug heads for lateral closing and locking of the modules in the 2.0 x 2.0 m base scaffolding assemblies	2.20	4.84
FLV16241-3	Diagonal crosspiece made with Ø 38 mm x 1.4 m RITZGLAS® tube and cast aluminum coupling heads, used for diagonal locking between two modules for 1.0 x 1.0 m base scaffolds	1.50	3.31
FLV16241-4	Diagonal crosspiece made with Ø 38 mm x 2.2 m RITZGLAS® tube and cast aluminum coupling heads, used for diagonal locking between two modules for 2.0 x 1.0 m base scaffolds	2.00	4.41
FLV16241-5	Diagonal crosspiece made with Ø 38 mm x 2.8 m RITZGLAS® tube and cast aluminum coupling heads, used for diagonal locking between two modules for 2.0 x 2.0 m base scaffolds	2.40	5.29



FLV06052-1



FLV09091-1



FLV13916-1



FLV16241-1

E



FLV16241-3

MAIN COMPONENT

Catalog Reference	Description	Approx. Weight	
		kg	lb
FLV17444-1	Platform made of 4 fiberglass planks with non-slip surface, used only for 2.0 x 1.0 m scaffold base assemblies	26.40	58.20
FLV17444-2	Platform made of 8 fiberglass planks with non-slip surface, used only for 2.0 x 2.0 m scaffold base assemblies	110.60	243.83
FLV17444-3	Platform made of 2 fiberglass planks with non-slip surface, used only for 1.0 x 1.0 m scaffold base assemblies	13.20	29.10
FLV04803-3	Rope insulating stick made with RITZGLAS® tube Ø 25 mm x 1.70 m, (1.54 m insulating length). It has an aluminum head and a steel butt-swivels, a tool necessary for scaffolding bracing (using 4 parts for each 4-meter high span is recommended). Its rated working capacity is 800 daN / 1764 lb	1.15	2.54
RM1895-3	White polypropylene multifilament rope, twisted on three legs in 220 m rolls, Ø 1/2". It is used in series with insulating spacer for scaffolding	0.07 (/m)	0.15



FLV17444-1



FLV17444-2

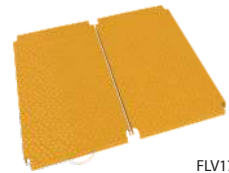

FLV17444-3



FLV04803-3



RM1895-3

MAIN COMPONENT



FLV05992-1



FLV31240



FLV31340

Catalog Reference	Description	Approx. Weight	
		kg	lb
FLV05992-1	Scaffold leveling jack	3.50	7.70
FLV31240-1	Set of 4 scaffolding casters 1.0 x 1.0 m base. Equipped with stabilizing shoes 108.40 238.98 and 2 steel rods for spacing and locking the scaffold base	108.40	238.98
FLV31240-2	A set of 4 casters to move the base scaffolding 2.0 x 1.0 m. Equipped with stabilizing shoes and 2 steel rods for spacing and locking the 108.40 238.98 scaffold base	108.40	238.98
FLV31240-3	Set of 4 scaffolding casters 2.0 x 2.0 m base. Equipped with stabilizing shoes 110.60 243.83 and 2 steel rods for spacing and locking the scaffold base	110.60	243.83
FLV31340-1	Set of rails for scaffold base 1.0 x 1.0 m and 2.0 x 1.0 m Intended to facilitate and align the horizontal locomotion of insulation scaffold assemblies through its caster on irregular floors, mainly in substations, where the presence of such irregularities is common. Connectable to each other through locking pins and against safety pins. It accompanies steel spacers, which have the purpose of aligning the assembly to facilitate the horizontal locomotion of the scaffold. The rails feature a strap for easy transport, assembly and disassembly of the assembly. It consists of three sets of rails, each with 2 meters in length, totaling 6 meters.	103.10	227.30
FLV31340-2	Set of rails for scaffold base 2.0 x 2.0 m	104.30	229.94

E

COMPONENT MEETING NR-18 BRAZILIAN STANDARD

Catalog Reference	Description	Approx. Weight	
		kg	lb
FLV16238-1	1.0 x 1.2 m railing module with cast aluminum connection. It has the same insulating and mechanical characteristics as the other modules, but with a height of 1.2 m. It is used exclusively at the work levels where the platform will be mounted	8.30	18.30
FLV17496-1	2.0 x 1.2 m railing module with cast aluminum connection. It has the same insulating and mechanical characteristics as the other modules, but with a height of 1.2 m. It is used exclusively at the work levels where the platform will be mounted	13.80	30.42
FLV16237-1	Intermediate crossarm made with Ø 38 mm x 1.0 m RITZGLAS® pole and collars at its ends. It is used for lateral closing of the scaffolding railing modules. 2.0 x 1.0 and 1.0 x 1.0 m, mounted 0.7 m high from the platform, providing greater user safety	2.30	5.07
FLV16237-2	Intermediate crossarm made with Ø 38 mm x 2.0 m RITZGLAS® tube and collars at its ends. It is used for side closure of the 2.0 x 2.0 m scaffolding rail modules, mounted 0.7 m high from the platform, providing greater safety for the user.	2.90	6.39
FLV16241-6	Side rail made of Ø 38 mm x 1.0 m RITZGLAS® tube and cast aluminum snap-on heads, responsible for side closing and locking the railing modules in 1.0 x 1.0 and 1.0 x 2.0 m scaffold assemblies	0.89	1.96
FLV16241-7	Side rail made of Ø 38 mm x 2.0 m RITZGLAS® tube and cast aluminum socket heads, responsible for side closing and locking the railing modules in 2.0 x 2.0 m scaffolding assemblies	2.20	4.48



FLV16238-1

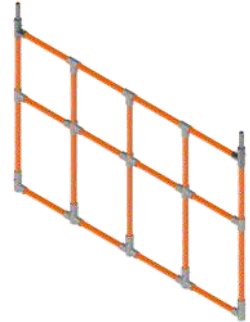

FLV17496-1



FLV16237-1

E



FLV16241-6

COMPONENT MEETING NR-18 BRAZILIAN STANDARD

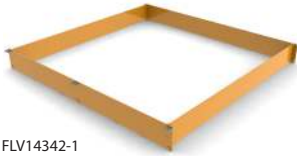

FLV14342-1

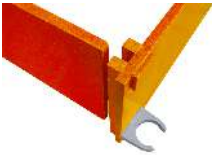

Catalog Reference	Description	Approx. Weight	
		kg	lb
FLV14342-1	Safety baseboard with mounting fittings to the scaffolding modules for installation on the base of the 1.0 x 1.0 m platform as a safety item in order to prevent accidental tool or component drops	8.00	17.64
FLV14342-2	Safety baseboard with mounting fittings to the scaffolding modules for installation on the base of the 2.0 x 1.0 m platform as a safety item in order to prevent accidental tool or component drops	12.30	27.12
FLV14342-3	Safety baseboard with mounting fittings to the scaffolding modules for installation on the base of the 2.0 x 2.0 m platform as a safety item in order to prevent accidental tool or component drops	16.00	35.37

ACCESSORIES



FLV09012-1



ESC15051-1

Catalog Reference	Description	Approx. Weight	
		kg	lb
FLV09012-1	0.50 x 1.0 m module, with the same insulating and mechanical properties as the other modules. However, this module is designed to obtain intermediate heights by providing its user with proper working positioning.	4.90	10.80
ESC15051-1	A scaffolding pole made of Ø 3/8" x 3.0 m RITZGLAS®. It has a fork head at one end and an eye head at the other end (both aluminum) couple two rods. If required, its rated working capacity is 500 daN (1102 lb)	0.70	1.54
ESC15051-2	A scaffolding pole made of Ø 3/8" x 2.0 m RITZGLAS®. It has a fork head at one end and an eye head at the other end (both aluminum) couple two rods. If required, its rated working capacity is 500 daN (1102 lb)	0.55	1.21
ESC15051-3	A scaffolding pole made of Ø 3/8" x 1.0 m RITZGLAS®. It has a fork head at one end and an eye head at the other end (both aluminum) couple two rods. If required, its rated working capacity is 500 daN (1102 lb)	0.40	0.88

ACCESSORIES

Catalog Reference	Description	Approx. Weight	
		kg	lb
FLV17648-1	Bracing strap made of cast bronze alloy. They have an hinged eye to couple the rope insulating stick. It is always installed in the scaffolding connections	0.40	0.88
FLV15444-1	Removable step for side mounting of scaffolding modules as a way to provide side steps where there is only a span	3.70	8.16
FLV18169-1	Heavy component lifting support, mounted on the upper right scaffolding module for easy lifting of heavy components. They have an axial angle of approximately 40 degrees in relation to the module that allows two supports to be mounted simultaneously for lifting larger materials with a maximum load capacity of 60 daN (132 lb)	2.00	4.41
FLV18169-2	Heavy component lifting bracket, installed on top left scaffolding module, with maximum load capacity of 60 daN (132lb)	2.00	4.41
FLV18269-1	Lift support. For easy lifting of its components during assembly and tools. Installed on the top scaffolding module with maximum load capacity of 40 daN (88 lb)	1.10	2.43
FLV18375-1	A tool box made of fiberglass. It has two metal cast aluminum clips for mounting to the scaffolding module. Suitable for safe and convenient tool placement during scaffolding maintenance Main dimensions: 0.62 x 0.22 x 0.20 m	4.90	10.80
FLV23916-1	Galvanized steel rod	1.60	3.50



FLV17648-1



FLV15444-1



FLV18169



FLV18269-1



FLV18375-1



FLV23916-1

ACCESSORIES



RC402-0288



MD800

Catalog Reference	Description	Approx. Weight	
		kg	lb
RC402-0288	Micro tester and micro ammeter used for leakage current measurement in scaffolding electric field tests. It has a scale from 0 to 200 μ A, supplied with clips, connection cable, a metal frame fixing device and a storage box.	3.26	7.19
MD800	Digital microammeter used for leakage current measurement in scaffolding field electric tests. It has a scale from 0 to 800 μ A, supplied with clips, connection cable, a metal frame fixing device and a storage box.	3.12	6.88
ATR30985-1	Temporary jumper for live line operations in substation for connector replacement, consisting of: 2 pç ATR13159-1 - All-around clamp with locking eye screw, in aluminum alloy, connected to the extra flexible copper wire 95mm ² (1.5 m) electrolytic copper conductor through smooth and lean and skirted copper terminal for 95mm (RC600-2633)	5.76	12.70



INSULATING SCAFFOLD EQUALIZATION AND GROUNDING KIT

FLV30722-1

Used for contact, equalization, and measurement of leakage current in tasks with insulating scaffold. It should only be used after testing the scaffolds with Ritz tester family appliances. The Kit is intended to ensure that the scaffold is in full working condition, with no leakage points between the energized potential and ground, for the lineman to enter the potential.



COMPOSIÇÃO

FLV30489-1 - Scaffold equalization device (touch to potential)

It is a device with a manufactured body and a rod (1m rod) made of aluminum, with a tightening and adjustment system in the scaffold tubes, allowing proper adjustment to touch the energized potential.

FLV30490-1 - Scaffold grounding set

Grounding cable composed of an RG3363-1 clamp and an ATR04467-2 clamp and 10m of 25mm² copper cable with smooth aluminum terminals at its ends, allows the grounding of the scaffold set (base) to a bus bar or substation grounding point.

FLV30707-1 - Scaffold base equalization device

Composed of 4 metal clamps, attached to the scaffold base using butterfly screws, joined together by coaxial cables and at one end with its own connector for connection and reading of the leakage current with microammeters RC402-0288 or MD800.



FLV30489-1



FLV30490-1



FLV30707-1



GROUP F



Access our site.



LOAD LIFTING TOOLS AND ACCESSORIES



Manual Hoists	179	Rope Insulating Stick	191
Insulating Pole for Hoists and Blocks	182	Rope Blocks	192
Gin Pole for Load Lifting	182	Snatch Blocks	194
Crossarm Gin	184	Sling	196
Insulated Gin Pole / Cargo Boom	185	Wire Grips	197
Swivel Boom with Mast	186	Tarpaulin for Live Line Tools	198
Rope	190		

LOAD LIFTING TOOLS AND ACCESSORIES

MANUAL HOISTS

Used in services of construction and maintenance of electrical networks for load handling. It has locking device for gradual descent of load which can be handled in two positions, to the right or to the left of the load application axis.

Hoists with Nylon Straps

Made with Ø 38mm RITZGLAS® fiberglass rod, traction mechanism and hooks made of metal, supplied in two handle versions: one with a plastic terminal (at the end for rubber glove work) and the other for hotstick work (via a handle with a rotating eye at the end). Its nylon straps can be purchased as replacement parts.



WARNING

The nylon-strap ratchet hoists are not considered insulation tools. For use in energized networks it is necessary to use insulating sticks compatible with the safety distance of table.



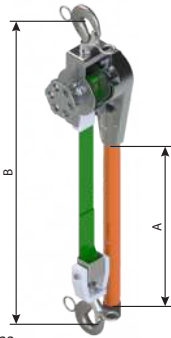

RC309-0323

HOIST WITH NYLON STRAP - 1 TON

Catalog Reference	Description	A Insulating Length (mm)	B Distance Between Hooks (mm)		Approx. Weight.	
			Min.	Max	kg	lb
RC309-0323	With regular handle	420	600	2500	6.30	13.89
RC309-0467	With hot stick handle	420	600	2500	7.20	15.85

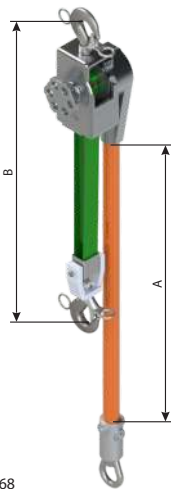

RC309-0468

HOIST WITH NYLON STRAP - 2 TON

Catalog Reference	Description	A Insulating Length (mm)	B Distance Between Hooks (mm)		Approx. Weight.	
			Min.	Max	kg	lb
RC312-0000	With regular handle	770	500	1775	7.80	17.20
RC309-0468	With hot stick handle	770	500	1775	8.80	19.40

CONVERTIBLE STRAP HOISTS (0.75 or 1.5 ton.)

Catalog Reference	Description	A Insulating Length (mm)	B Distance Between Hooks (mm)		Approx. Weight.	
			Min.	Max	kg	lb
RC309-0451	With regular handle	590	546	2740 (0.75 ton.) 1370 (1.5 ton.)	5.30	11.68
RC309-0452	With hot stick handle	650	546	2740 (0.75 ton.) 1370 (1.5 ton.)	5.60	12.34

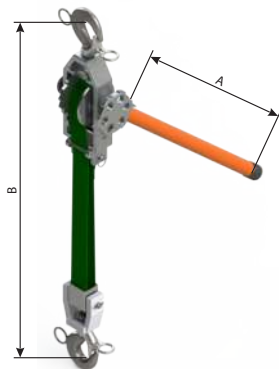

RC309-0451

The convertible nylon strap hoists are lightweight, sturdy, and versatile. Allow conversion of workload capacity of 0.75 ton. or 1.5 tons, simply by arranging the nylon straps.

F

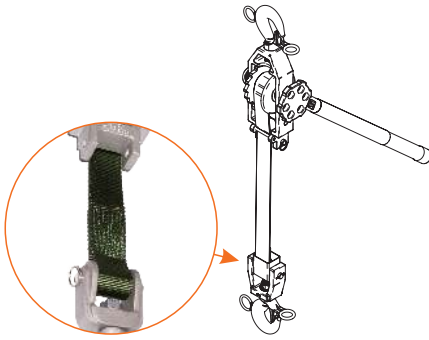

To use the 0.75 ton load capacity, attach the load hook sheave to the free end loop of the strap.

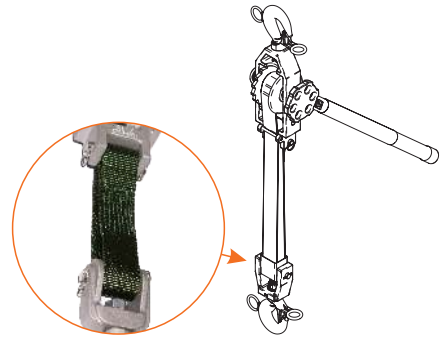

To convert hoist load capacity from 0.75 ton. to 1.5 ton. keep the load hook sheave installed in the middle of the nylon strap when it is folded and with the end of the strap attached to the hoist body.

Chain Ratchet Hoists

Lightweight and quick to operate, it has features for greater operator productivity when working in tight spaces because its drive handle operates on all sides of the load.

For easy coupling and load alignment, it has forged steel hooks with a safety lock and 360° swivel.

For safety reasons, the chains are released for free-form movement only when there is no load.

The hoists have two control levers: the first to change movement direction; the second to activate the movement safety lock.

Control levers are easy to operate even with gloves on.

Catalog Reference	Rated Working Capacity (ton.)	Approx. Weight.	
		kg	lb
750E	0.75	7.30	16.09
1500E	1.50	11.50	25.35
3000E	3.00	17.00	37.48
6000E	6.00	23.00	50.70



1500E

INSULATING POLE FOR HOISTS AND BLOCKS

They can safely transform a nylon strap hoist or block into insulating equipment to use it in energized installations.

It has a steel safety hook at one end and a steel swivel eye at the other. Its eye is mounted to one of the hoist or block hooks to ensure its insulation from the grounded parts of the structure.



RC400-1175

Catalog Reference	Ø (m)	Insulating Length (mm)	Rated Work Capacity		Approx. Weight.	
			daN	lb	kg	lb
RC400-1175	32	407	2000	4409	2.00	4.40
RC400-2399		487			2.40	5.30
RC400-2400		637			3.10	6.80

GIN POLE FOR LOAD LIFTING

They are lightweight, mechanically resistant, and easy to install tools. They have excellent safety and productivity gains in lifting equipment and materials, as well as in the construction and maintenance of medium voltage overhead lines.

They were manufactured with cast aluminum metal parts and RITZGLAS® insulating tube.

NOTES

- Gins are not designed for applications involving hand rope side pulling or misaligned loading. Therefore, force direction must be parallel and aligned with the gin.
- When calculating load capacity, consider a 10% loss due to friction on pull ropes (friction).

Example: Using a double block lift system the maximum load to be lifted will be 635 daN (1400 lb). A snatch blocks must be attached to the base of the frame to pass the hand rope of the block.

Using a simple lifting system the maximum load will be 408 daN (900 lb). Hoist load plus pulling force and frictional force equals gin capacity.

RC400-0090

Only mount in free areas of the pole (without a spacer saddle).



RC400-0090

RC400-0315

It can be coupled to a spacer saddle, which allows it to be mounted next to crossarms. It is coupled to the pole by a chain stretcher and tightened by a handwheel.



RC400-0315

RC400-0578

This gin combines the advantages of a multiple tool in the use of lifting equipment and materials.

They are coupled to the "T" double concrete pole by two galvanized steel bolts with wing nuts using the pole holes.

In circular concrete poles, it is coupled by conventional metal straps. Due to its length, the gin has a platform at its upper part of the pole, helping in handling lifted equipment.

Since this tool has 04 clamping positions, the following rated working capacity must be observed:

- 1° hole: 100 daN (220 lb) at base side
- 2° hole: 150 daN (330 lb)
- 3° hole: 200 daN (440 lb)
- 4° hole: 250 daN (550 lb) at upper side.



RC400-0578

GINS FOR LOAD LIFTING

Catalog Reference	Description	Rated Work Capacity		Ø (mm)	Length (m)		Approx. Weight.	
		daN	lb		Insulating	Total	kg	lb
RC400-0090	With chain-mounted pole saddle of 0.92 m	907	2000	76	0.54	0.68	7.10	15.65
RC400-0315	With 0.13 m spacer saddle for mounting to pole through 0.92 m chain	907	2000	76	0.52	0.68	9.80	21.60
RC400-0578	With direct mounting system to square pole through two screws with wing nut, aid of two conventional straps conventional	110 to 250	250 to 550	64	1.05	1.83	12.20	26.90





CROSSARM GIN

Provided with clevis type saddle to fit over distribution crossarms, allowing the use of blocks or ropes to lift the conductors from the insulators.

RH20 and RT400-0870 can be inverted and have a removable galvanized steel pin for better adjustment on the crossarm.

Catalog Reference	Description	Crossarm Dimensions (mm)	Rated Work Capacity		Insulating Length (m)	Approx. Weight.	
			Max Angle 30°	daN		lb	kg
FLV08257-3	No convertible	75 x 75	340	750	0.71	7.70	16.96
RH20	Convertible	89 x 114 to 21 x 146	340	750	0.71	7.70	16.96
RT400-0870	Convertible		227	500	1.06	8.20	18.00

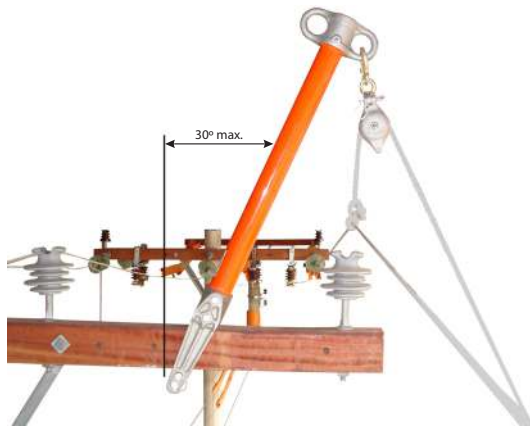

F

INSULATED GIN POLE / CARGO BOOM

The heavy load lifting gin is made with RITZGLAS® square tube and has three chain stretchers, with handwheels for coupling to the structures.

The square head at the top of the pole has two shackles for easy load fixing. By attaching a pole clamp to the coupling on top of this pole, a wire tong can be used for increased stabilization.

The load lift boom has a square pole clamp (RE400-0434) installed near its end. This clamp can be adjusted in three positions for better positioning of the lifting load as well as its retention to the structure.

The lower coupling hinged saddle allows the boom to be moved 90°, i.e. from horizontal to vertical and vice versa, as well as to rotate 180°. Its upper head is similar to that of the gin pole.

NOTE

Rated work loads include pulling force.

GIN POLE

Catalog Reference	Size (mm) □	Insulating Length (m)	Rated Work Capacity		Approx. Weight.	
			daN	lb	kg	lb
RC400-0470	100 x 100	2.28	2268	5000	33.20	73.19
RC400-0472		3.50			40.40	89.07

CARGO BOOM

Catalog Reference	Size (mm) □	Insulating Length (m)	Rated Work Capacity		Mounting	Approx. Weight.	
			daN	lb		kg	lb
RC400-0475	100 x 100	4.72	454	1000	Pole	45.60	100.53
RC400-0483					Tower	45.00	99.21

SPARE PART

Catalog Reference	Description	Approx. Weight.	
		kg	lb
RE400-0434	Square pole clamp for cargo boom	4.00	8.82

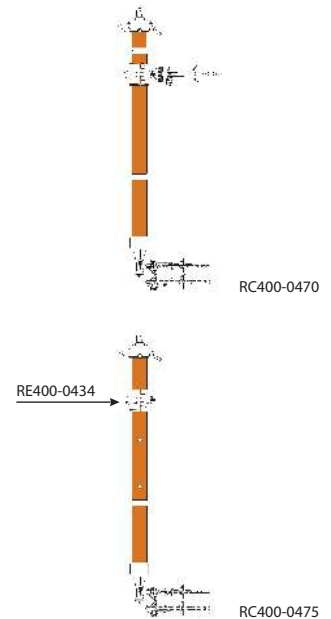

SWIVEL BOOM WITH MAST



R070496



RC400-0602



FLV01644-1



FLV18133-1



RH4721-112

The boom pole with mast is intended for heavy duty high voltage structures, particularly for removing insulator chains with the aid of the cradle.

In the boom poles with mast (RC400-0469 and RH1973/H-10) two saddles (R070496) already included are used to attach the gin to the pole: one at the top and one at the bottom. These saddles have handwheel chain stretchers.

In the boom poles with mast (RC400-0464, RC400-0465 and RH1973-814), designed for tower mounting, two hardware models are used: a saddle (RC400-0602) mounted on the underside, which is attached to the tower, with two sets of screws and angle jaws, and a triple fork (FLV01644-1), already included, installed on the upper side, for coupling the trolley poles.

When the mast is not necessary, the adapter (FLV18133-1) must be used to couple the boom to the saddle (RC400-0602).

The coupling and the formation of the mast stabilization tripod on the metal frame are made by three trolley poles (RH4721-112) and respective metal frame saddles (RM4742-3), both specified separately.

The trolley pole have heat-treated aluminum alloy heads and forged steel swivel eye.

On all models, the mast is held in the mast with a strain link stick (RC400-0816) and a hoist (1500E), both specified separately.

The mobile pole clamp on the square boom (RC400-0464, RC400-0465 and RC400-0469) can be adjusted to three different positions for easy operation of the assembly at different angles of the insulator chain. The boom has at its end an auxiliary head with two shackles for retaining or holding additional loads, tools, etc

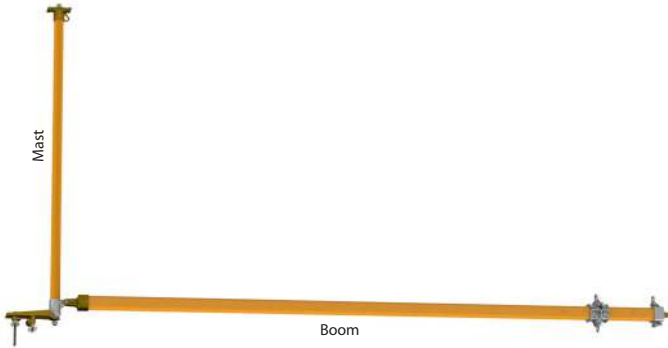

SWIVEL BOOM WITH MAST - HEAVY DUTY

Catalog Reference	Ø 76 mm Mast Insulating Length (m)	Composition of the Set			RC400-0602	FLV01644-1	R070496	Approx. Weight.	
		□ 100 x 100 mm Boom Insulating Length (m)	Rated Work Capacity					kg	lb
			daN	lb					
RC400-0464*	2.30	4.72			01	01	-	58.50	128.97
RC400-0465*	2.91	5.33	454	1000	01	01	-	63.90	140.88
RC400-0469**	2.91	5.33			-	-	02	63.90	140.88

* Metal structure coupling | ** Pole coupling

NOTE



The swivel boom with mast has the rated working capacity above only when mounted with the arm support tripod, consisting of 3 trolley poles, 1 strain link stick, and 1 2-ton hoist (purchased separately).

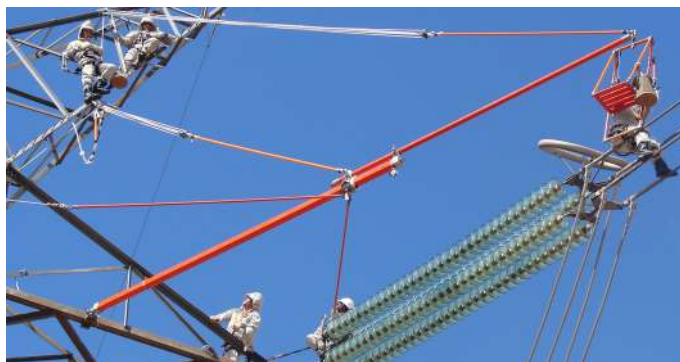

The square swivel boom extension is used to bring the electrician to potential through the potential access chair (FLV12563-1).

It has two Ø 76 mm bronze alloy pole clamp (FLV00196-5) for coupling to the square head and the square pole clamp of the boom pole. It also has a head with two eyes, one for installation of the potential access chair and other for bracing with an insulating pole and block.



FLV18617-1

EXTENSION FOR SQUARE SWIVEL BOOM WITH MAST

Catalog Reference	Ø (mm)	Insulating Length (m)	Rated Work Capacity		Approx. Weight.	
			daN	lb	kg	lb
FLV18617-1	76	4.00	140	309	16.64	36.68

SWIVEL BOOM WITH MAST - MEDIUM DUTY

Catalog Reference	Ø 76 mm Mast Insulating Length (m)	Ø 76 mm Boom Insulation Length (m)	Composition of the Set				Approx. Weight.		
			Rated Work Capacity		RC400-0602	FLV01644-1	R070496	kg	lb
			daN	lb					
RH1973-814*	2.30	4.09	227	500	01	01	-	38.80	85.54
RH1973/H-10**	1.68	2.87	272	600	-	-	02	27.60	60.85

* Metal structure coupling. | ** Pole coupling

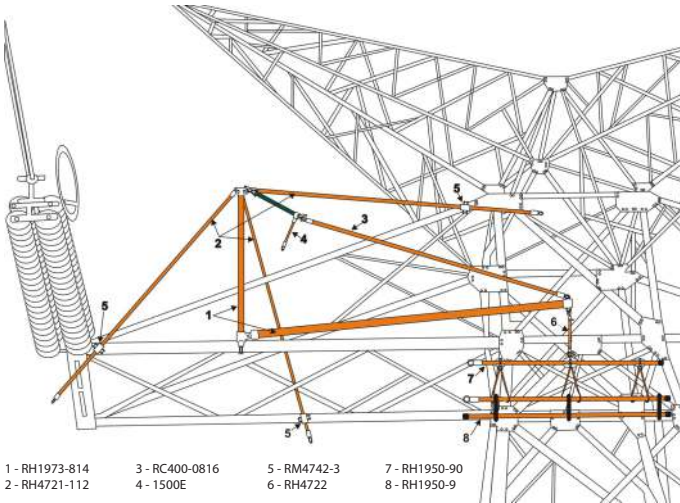

1 - RH1973-814 3 - RC400-0816 5 - RM4742-3 7 - RH1950-90
 2 - RH4721-112 4 - 1500E 6 - RH4722 8 - RH1950-9

(Items 2 through 8: separate specifications)

NOTE

For loads greater than 272 daN (600 lb) we suggest using the metal frame saddle (RM4742) with a 76 mm bronze alloy pole clamp (FLV00196-5) and an identical rear pole clamp to prevent slippage of the trolley pole used on the mast support tripod.

ACCESSORY FOR SWIVEL BOOM WITH MAST

Catalog Reference	Description	Approx. Weight.	
		kg	lb
R070496	Saddle	7.00	15.43
RC400-0602	Saddle for Tower Bracket	10.30	22.70
FLV01644-1	Triple Fork	1.95	4.30
FLV00196-5	Bronze alloy pole clamp Ø 76 mm	2.62	5.78
FLV18133-1	Swivel Boom adapter to the structure	1.00	2.20

ROPE

Polypropylene Rope

The polypropylene rope was selected for its mechanical strength, reduced elongation, and lightness.

This rope, like all other ropes for hot line work, should always be kept clean and stored in a dry place and sheltered from the sun.

Although the polypropylene rope has good dielectric strength when new, it is not insulating for hot line work. Therefore, if it contacts energized parts, an insulating rope spacer must be used with it.

It comes in white color, with three-legged polypropylene multifilament formation and a 220 meter roll.



Catalog Reference	Ø		Rated Working Capacity		Minimum Breaking Strength		Approx. Weight.	
	in.	mm	daN	lb	daN	lb	kg/m	lb/m
RM1895-1	1/4"	6.00	107	236	537	1184	0.02	0.04
RM1895-2	3/8"	9.50	230	507	1153	2542	0.04	0.09
RM1895-3	1/2"	12.50	402	886	2010	4430	0.07	0.15
RM1895-4	5/8"	15.50	582	1283	2910	6415	0.12	0.26
RM1895-5	3/4"	19.00	734	1618	3670	8090	0.17	0.37

* 20% of minimum breaking strength

Polydacron Rope

Three-legged fiber twisted rope combined with excellent service life and high strength-to-weight ratio. The rope is made of high-strength polyester surface yarns wrapped in high tenacity polyolefin fiber. It also offers the durability of polyester, but with greater strength than other ropes due to the combination with polyolefin fiber.

The rope is not considered insulating for hot line work. Therefore, if it contacts energized parts, an insulating rope spacer must be used with it.

It comes in a 183 meter roll.



Catalog Reference	Ø		Rated Working Capacity*		Minimum Breaking Strength		Approx. Weight.	
	in.	mm	daN	lb	daN	lb	kg/m	lb/m
RM1896-2	3/8"	9.50	335	740	1700	3700	0.05	0.11
RM1896-3	1/2"	12.50	560	1240	2800	6200	0.09	0.20
RM1896-4	5/8"	15.50	815	1800	4100	9000	0.14	0.31

* 20% of minimum breaking strength



Safety Rope

Rope woven into three strands of polyester multifilament and central core of polyamide multifilament, lightweight and with good mechanical resistance.

For specific use in hanging chairs and safety guide cable for securing fall arrest and lifeline installation.

This rope is not considered insulating for work on energized installations.

Catalog Reference	Roll Length	Ø	Rated Working Capacity*		Minimum Breaking Strength		Approx. Weight.	
			m	mm	daN	lb	daN	lb
RM1897-50	50	12	460	1012	2300	5060	0.108	0.237
RM1897-100	100							
RM1897-200	200							
RM1897-250	250							

* 20% of minimum breaking strength



ROPE INSULATING STICK

It is used in series with the polypropylene rope when its direct contact with live parts of the installation is likely.

It is made with RITZGLAS® tube, heat treated aluminum alloy heads, and forged steel swivel eyes.



Catalog Reference	Ø (mm)	Insulating Length (m)	Rated Working Capacity		Approx. Weight.	
			daN	lb	kg	lb
FLV04803-1	25.4	0.42	800	1764	0.63	1.39
FLV04803-2		1.04			0.95	2.09
FLV04803-3		1.54			1.15	2.54

ROPE BLOCKS

With thermoplastic housings and sheaves, steel hooks with safety locks (with continuous rotation on their shaft), it provides easier coupling and alignment with the load.

When only blocks are purchased, we note that the pairs are formed with one block unit with rope becket (FLV10893-1) and another unit without this device (RC400-0918).

Common Rope Blocks

Equipped with an eye for hot-stick mounting.

Block dielectric strength: 30 kV

Light Block

Compact and resistant, this tool has been specially developed for use in electrical and telecommunication, lifting loads, cable pulling, gins, etc.

It has 15 meters of rope (RM1895-2).

ROPE BLOCKS

Catalog Reference	Description	Rated Work Capacity		Approx. Weight.	
		daN	lb	kg	lb
RC400-0914	Complete double block mounted with 38 m rope (RM1895-3)	1589	3500	7.20	15.87
RC400-0915	Complete triple block mounted with 45 m rope (RM1895-3)	1589	3500	7.90	17.40
RC400-0925	Triple block with 45m Polydracon rope (RM1896-3)	1589	3500	8.00	17.5
RC400-0916	Single block (1 sheave) without becket	907	2000	0.96	2.10
RC400-0917	Single block (1 sheave) with becket	907	2000	1.05	2.30
RC400-0918	Triple block (3 sheaves) without becket	1589	3500	2.00	4.40
FLV10893-1	Triple block (3 sheaves) with becket	1589	3500	2.00	4.40
RC400-0919	Double block (2 sheaves) without becket	1589	3500	2.00	4.40
FLV16813-1	Block for double block (2 sheaves) with becket	1589	3500	2.00	4.40
FLV07777-1	Complete lightweight double block with 15 m rope (RM1895-2)	400	880	2.10	4.62



SNATCH BLOCKS

Indispensable equipment in cargo handling and lifting operations in construction and maintenance work in electrical and telephone installations.

The two versions of hooks available (drawn or forged steel) are designed for easy mounting of the snatch block to their installation location.

The body and sheave are constructed of heat treated aluminum alloy and have a folding device to allow the introduction of a quick swiveling service rope over the sheave.

The RC417-6067 and R2230-1 have forged steel hooks and safety lock, and the R2230-2 have a cold drawn steel hook without safety lock.

The rope hook is made of stainless steel and is designed for easy lifting of loads or tools. It has two holes to mount the rope and its tip is slightly curved for easy tool introduction.

NOTES

- For safety reasons, hoisted equipment should always be seated on the hook bed when transporting..
- The spool bracket (RM1979) is made with angle bracket, continuously rotating forged steel eye for spool support, bronze claws, two steel bolts and wing nuts for attachment to the metal frame.
- The five holes in the snatch block holder allow them to fit differently sized metal structures.

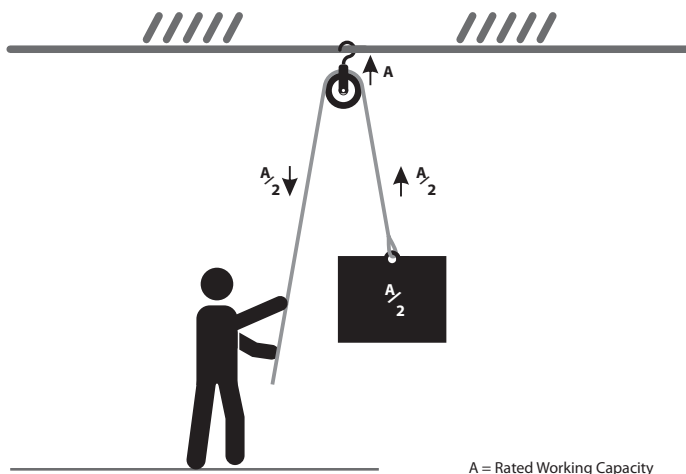

ALUMINUM SNATCH BLOCKS

Catalog Reference	Description	Rated Work Capacity		Approx. Weight.	
		daN	lb	kg	lb
RC417-6067	For ropes up to Ø 5/8"; with forged steel hook and safety lock	1134	2500	2.60	5.70
R2230-1	For ropes up to Ø 5/8"; with forged steel hook and safety lock	567	1250	1.10	2.42
R2230-2	For ropes up to Ø 5/8"; with drawn steel	567	1250	1.0	2.42



RC417-6067



R2230-1



R2230-2

SNATCH BLOCKS ACCESSORY

Catalog Reference	Description	Rated Work Capacity		Approx. Weight.	
		daN	lb	kg	lb
RM1849	Stainless steel alloy rope hook. It has two holes for rope mounting	250	551	0.30	0.67
FLV29635-1	Stainless steel alloy rope hook. It has two holes rope mounting with safety lock	250	551	0.31	0.68
RM1979	Aluminum snatch block support with fitting for metal frame mounting and 76 x 76 mm flaps and total length of 475 mm	567	1250	6.00	13.20



RM1849



FLV29635-1



RM1979

SLING

The webbing slings (non-insulating) have been designed to couple loads to the respective tools or traction equipment and from these to the work structure. They are therefore widely used in cargo handling and traction of electrical and telephone cables. Models made without any metal components are easy to handle and pack due to their flexibility.

They are available in two basic types:



RC417-0133

“Return Eye” Style

One size only. This model was primarily designed for the hanger arrangement, but can also be used with upright hooks and basket.



RC417-0134

“Endless” Model

With five size options. This is the most versatile model of all. It can be used in vertical, hanger or basket arrangements, and adapts well to the shape of the load. It provides greater grip strength and upright support. It's easier to use and longer lasting because it has no eyes that establish wear points.

POLYESTER WEBBING SLINGS

Catalog Reference	Width (mm)	Length (m)	Rated Working Capacity by lifting type										Type
			Basket		Strength		Vertical		up to 45°		from 45° to 60°		
			daN	lb	daN	lb	daN	lb	daN	lb	daN	lb	
RC417-0133	60	1.83	4000	8818	1600	3527	2000	4410	2800	6173	2000	4410	Return Eye
RC417-0134	30	0.92	2000	4410	800	1764	1000	2205	1400	3086	1000	2205	Endless
RC417-0135	30	1.22	2000	4410	800	1764	1000	2205	1400	3086	1000	2205	
RC417-0136	30	1.52	2000	4410	800	1764	1000	2205	1400	3086	1000	2205	
RC417-0137	30	1.83	2000	4410	800	1764	1000	2205	1400	3086	1000	2205	
RC417-0138	30	2.44	2000	4410	800	1764	1000	2205	1400	3086	1000	2205	
RC417-0139	60	0.92	4000	8818	1600	3527	2000	4410	2800	6173	2000	4410	
RC417-0140	60	1.22	4000	8818	1600	3527	2000	4410	2800	6173	2000	4410	
RC417-0141	60	1.52	4000	8818	1600	3527	2000	4410	2800	6173	2000	4410	
RC417-0142	60	1.83	4000	8818	1600	3527	2000	4410	2800	6173	2000	4410	
RC417-0143	60	2.44	4000	8818	1600	3527	2000	4410	2800	6173	2000	4410	

F

Nylon looped slings are made with nylon strap, providing more malleability and grip without damaging the object being handled.

They come in three different lengths with equal load capacity in the three configurations: basket, hanger, and vertical.

They have steel rings at their ends, with surface treatment in D-shape, for easy mounting with a hot stick.

Catalog Reference	Width (mm)	Insulating Length (m)	Rated Work Capacity		Approx. Weight.	
			daN	lb	kg	lb
FLV06619-1	50	0.50	670	1477	0.55	1.21
FLV06619-2		0.80			0.65	1.43
FLV06619-3		1.20			0.75	1.65



FLV06619-2

WIRE GRIPS

Intended for hot line conductor straining.

The movable grip on top provides its installation to the conductor by using an insulating hot stick and also, when loose, it can be used as a locking device, preventing it from falling off accidentally.



Catalog Reference	Conductor Ø (mm)		Rated Capacity				Jaw		Approx. Weight.	
	Minimum	Maximum	Work		Rupture		Type	Material	kg	lb
			daN	lb	daN	lb				
51.E07.D20-CE	5.08	10.16	800	1764	2000	4409	DR	Bronze	1.48	3.26
51.E07.D30-CE	7.87	13.50	800	1764	2000	4409			1.90	4.19
51.E07.D40-CE	13.41	18.80	1700	3748	3600	7937			3.50	7.72
51.E07.D50-CE	18.80	21.80	1700	3748	3600	7937			3.50	7.72

The DR (Double Round) jaw shape is suitable for aluminum and copper cables



DR Jaw

TARPAULIN FOR LIVE LINE TOOLS

It is used as a soil cover for the purpose of placing the selected tools for interventions in installations. In addition to protecting them against contamination, it establishes a place for inspection and selection of equipment to be used.

This tarpaulin is made of double-sided vinyl.



Catalog Reference	Dimensions (m)	Approx. Weight.	
		kg	lb
RT306-0014	4 x 3	9.15	20.17



Access our site.

CONDUCTOR SUPPORT EQUIPMENT



Wire Tongs	201	Strain Pole Clevis-Eye / Clevis-Clevis	226
Wire Tong Band	205	Adjustable Strain Poles	227
Wire Tong Blocks Clamp	206	Sectional Strain Pole (with Splice).....	229
Wire Tong Swivel	207	Light-weight Strain Carrier.....	230
Saddle and Components	207	Distribution Strain Carrier	234
Tower Type Saddles	212	Two-Pole Strain Carrier	236
Dual Auxiliary Arm	213	Auxiliary Strain Carrier.....	238
Auxiliary Crossarms	216	Accessories for Strain Carrier.....	240
Extension Arm	217	Heavy-Duty Suspension Link Stick	242
Auxiliary Crossarm Support for Aerial Device.....	218	Adjustable Hook Assembly	243
Temporary Conductor Support	219	Suspension Pole with Adjustable Hook	243
Hot Stick Tension Puller	221	Yoke	244
Symmetrical Tension Puller	222	Static Ground	249
Strain Link Stick	222	Cradle.....	250
Spiral Link Stick	224	"J"- Hook Assembly	256
Roller Link Stick	225	Trolley Pole.....	257

CONDUCTOR SUPPORT EQUIPMENT



WIRE TONGS

It is generally used to hold and move energized conductors from their original positions. It allows electricians to service crossarms, insulators, removing and placement of poles and hardware, as well as mounting new components, such as lightning arresters, in overhead lines.

This stick is usually operated in pairs or with other complementary tools such as: saddles; clamps; blocks. All are specially designed for quick and safe service.

Constructed with RITZGLAS® tube and aluminum alloy fittings (for better mechanical strength and lightness ratio), the steel swivel eye has a bearing for smooth and perfect rotation.

The varying wire tong jaw opening allows the conductor to be firmly and securely fixed by rotating the bar until the jaw is fully closed.

The diagrams show correct orientation of the use of the wire tongs through the four most used configurations and their workloads.

The electrician must strictly observe the safety distances when using the hot line poles, according to their recommended voltages in the OSHA table.

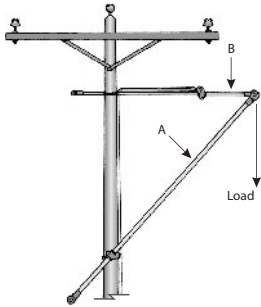

Wire tong with saddle, wire tong blocks clamp, and conductor pulling blocks.

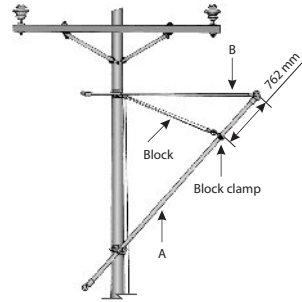

Wire tongs with saddles, wire tong band, and conductor pulling block.

WORKING LOADS*

Figure N°	RITZGLAS® Pole Dimensions Ø (mm) / Length (m)		Support Type	Max. Workload (per Conductor)		Maximum Conductor Size and Span (m)			
	A	B		daN	lb	ACSR		Copper	
						Size	Span	Size	Span
1	51 x 3.55	38 x 2.96	Pole saddle and lift saddle	125	276	4/0	213	4/0	91
	64 x 3.51			215	474		366		152
2	51 x 3.55	38 x 2.96	Pole saddle and lift saddle	125	276	4/0	213	4/0	91
	64 x 3.51			215	474		366		152

* Based on a fully horizontal wire tong. The lower the upper saddle is placed, below the conductor's level, the higher the tension on pole "A" will be, so the load it can support will be lower

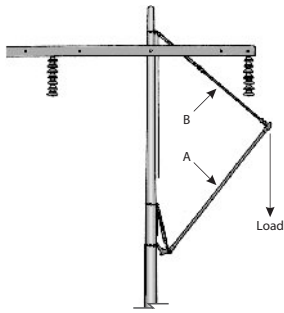

Wire tongs, lift saddle, tourniquet pull pole and block used to pull heavy conductors.

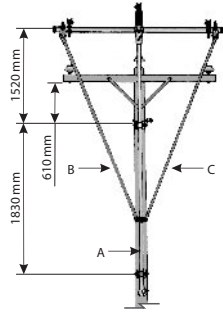

Set for lifting the three phases where all three conductors are raised simultaneously.

WORKING LOADS

Figura N°	RITZGLAS® Pole Dimensions Ø (mm) / Length (m)			Support Type	Max. Workload (per Conductor)		Maximum Conductor Size and Span (m)			
	A	B	C		daN	lb	ACSR		Coppe	
							Size	Span	Size	Span
3	51 x 3.55	38	-	Lift Saddle	160	353	4/0	259	4/0	114
	64 x 3.51						397.5	350	250	259
4	64 x 3.51	51 x 2.33	51 x 2.33	Pole Saddles	102	225*	4/0	168	4/0	70

* With maximum lift of 1.52m above the saddle and maximum unbalance of 102 daN/225 lb on one side.



WARNING

WORKLOADS - For the correct selection of tools, the loading information of the structure must be used. When these values cannot be obtained, the whole work structure must be analyzed before the load is applied.

When calculations are not possible (e.g. when a pole is slightly larger than its adjacent pole) just consider the total weight of the adjacent spans as the maximum workload. This does not apply to structures installed at high points, which requires special analysis for load determination.

If the workload is higher than indicated in the table (for a specified pole), use two wire tongs with double lift saddle or use a larger Ø wire tong.

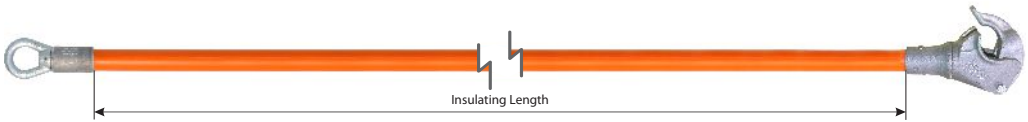

WIRE TONGS

Catalog Reference	Ø (mm)	Insulating Length (m)	Total Length (m)	Conductor Ø (mm)		Rated Work Capacity (traction)		Storage (optional)	Approx. Weight	
				Min.	Max.	daN	lb		kg	lb
RH4645-6	38	1.74	1.99	4.10	57.00	340	750	FLV18339-13	3.30	7.28
RH4645-8	38	2.35	2.60			340	750	FLV18339-3	3.80	8.38
RH4645-10	38	2.95	3.20			340	750	FLV18339-4	4.20	9.26
RH4646-6	51	1.72	1.99			454	1000	FLV18339-13	4.60	10.14
RH4646-8	51	2.31	2.58			454	1000	FLV18339-3	5.30	11.68
RH4646-10	51	2.94	3.20			454	1000	FLV18339-4	6.00	13.23
RH4646-12	51	3.60	3.87			454	1000	FLV18339-5	7.50	16.53
RH4647-8	64	2.29	2.61			567	1250	FLV18339-3	7.30	16.09
RH4647-10	64	2.90	3.21			567	1250	FLV18339-4	8.40	18.52
RH4647-12	64	3.45	3.77			567	1250	FLV18339-5	9.40	20.72
RH4647-14	64	4.12	4.44			567	1250	FLV18339-14	10.40	22.93
RH4647-16*	64	4.74	5.06			567	1250	FLV18339-3	13.90	30.64
RC400-0171	76	3.45	3.78			680	1500	FLV18339-5	12.70	28.00
RC400-0172	76	4.21	4.54			680	1500	FLV18339-14	14.90	32.85

* Spliced wire tong



The RH4647-16 is spliced wire tong, making it easy to carry. The connection between the two parts is made through a metal splice, of galvanized and fixed steel, with steel pin and pin type cotter pin.

WIRE TONG BAND

They are installed in the wire tong to be used as a pulling point in the block, for the articulation of these poles during the removal and subsequent approach of the conductor.

To ensure effective insulation between the block and live conductors, the clamp must be installed on the pole at a minimum distance according to its voltage class or more.

This tool is built in four different diameters, with a ring for direct contact with the pole and in aluminum alloy for the free rotation of the pole, once mounted to it, through two screws. The lifting eye is made of bronze alloy and has a pivot to follow the pull tool to the pole.



Catalog Reference	Ø (mm)	Load Capacity		Approx. Weight	
		daN	lb	kg	lb
RM1729	51	680	1500	0.61	1.34
RM1729-1	64			0.65	1.43
RM1729-2	76			0.70	1.54
RM1729-3	38			0.33	0.73

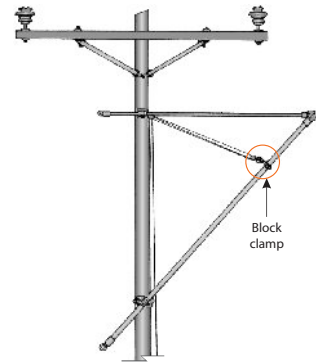

WIRE TONG BLOCKS CLAMP



Designed as a mounting point for wire tong pulling, with the aid of a block, which is connected to the block clamp eye. This arrangement aligns the pulling forces with the wire tong, helping to lift heavy conductors back to their original position.

The clamp is made of aluminum alloy, whose ring is the tightening screw and with a wing nut in bronze alloy.

The inner walls of the clamp are lined with a stainless steel blade, protecting the surface of the pole from mechanical damage.

The clamp consists of two halves, which are open for coupling and mounting to the pole by tightening the wing nut installed on one of the clamp tabs.

The wing nut device has a spring for easy, quick, and safe clamp operation.

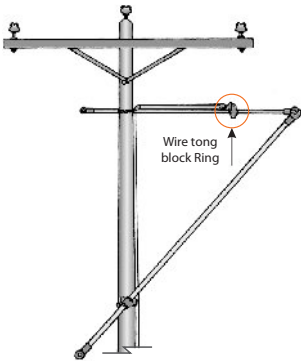

Catalog Reference	Ø (mm)	Rated Work Capacity		Approx. Weight	
		daN	lb	kg	lb
RM4743	38	560	1235	1.10	2.43
RM4743-1	51			1.20	2.65
RM4743-2	64			1.20	2.87

WIRE TONG SWIVEL

Useful tool for a safe movement of conductor through the arrangement of two wire tongs.

The Wire Tong Swivel have four different diameters models. The tool structure is made by a direct contact ring to the pole, a shackle, both made of aluminum alloy, besides the circular handles made of bronze alloy.

The contact ring is installed on the body of the wire tong head, which is coupled to the conductor. The other wire tong is attached to the collar strap, forming a pivoting assembly. Thus, the collar prevents two wire tongs, connected on the same cable, from twisting or event breaking it.

Meets the requirements of the IEC61236 standard.

Catalog Reference	Ø (mm)	Rated Work Capacity		Approx. Weight	
		daN	lb	kg	lb
FLV16599-1	38	270	607	0.85	1.87
RM4745	51	270	607	0.90	1.98
RM4745-1	64	270	607	0.98	2.16
RM4745-2	76	270	607	1.10	2.42



SADDLES AND COMPONENTS

RM1846-W

Saddle of rope lashing for poles is a simple and practical tool, it has six ring where the ropes can be tied, avoid undue embarrassment of them.

It has chain tensioner (RM1848-W) with a length of 915 mm for coupling to the pole with steering wheel to make the final adjustment. Made of heat treated aluminum alloy to meet the demands of work load and lightness in handling.



RM1846-W



RM4744



RM4760-W



RM4760-1W



RC400-1016

FLV4740-3W

FLV4740-4W

FLV4740-5W

FLV4740-9W

FLV4740-10W

FLV4740-15W

FLV4740-16W

FLV4740-17W

FLV4740-18W

FLV4740-19W

FLV4740-20W

Manufactured in according to standard IEC-61236.

This tool is used as a coupling point for poles, blocks, or masts, allowing the hot poles to move away from the utility pole.

Available models include: saddles with clamp; with extension and clamp; with shackle and with extension and shackle.

Base made of heat treated aluminum alloy and stainless steel chain coupling to meet the demands of work load and lightness in handling, shackle and saddle coupling made of cast bronze. It has chain stretcher (FLV00049-3) with length of 915 mm for coupling to the pole with steering wheel to make the final adjustment.

RM4744

Crossarm type saddle, useful for reduced workspace or already mounted with one or more pole saddles. The shackle installed on the saddle body, in turn, provides freedom of movement and allows the wire tong to move freely in either direction. It can be used on 76 x 108 mm and 102 x 203 mm.

RM4760-W (Simple)

RM4760-1W (double)

Lifting saddle intended for coupling point connection of stick, rope blocks or masts for spacing from poles in "H" type frameworks or whenever the working clearance is too limited.

Made with base and shoe of heat treated aluminum alloy to meet the demands of work load and lightness in handling, support strap and chain coupling made of steel, and saddle strap made of cast bronze. It has chain tensioner (RM1848-W) for coupling to the pole with steering wheel to make the final adjustment. It is equipped with strap and pin for connection of the rope block and wire tong respectively, allowing the free movement of both.

RC400-1016

The single lift saddle, belonging to the group of conductor support equipment. Made of RITZGLAS® This saddle is equipped with a handle and pin to connect the block and wire tong, respectively, allowing free movement of both.

Used when the work space on the pole is limited, provides a total conductor lift of up to 915 mm. With the same load capacity as the aluminum lift saddles, but normally used in higher voltage systems where more room is needed to lift the conductors.

SADDLE

Catalog Reference	Description	Rated Work Capacity		Approx. Weight	
		daN	lb	kg	lb
RM1846-W	Rope tie saddle	454	1000	3.40	7.50
FLV4740-3W	Saddle and tightener with 38 mm clamp	454	1000	4.90	10.80
FLV4740-4W	Saddle and tightener with 51 mm clamp	454	1000	5.00	11.02
FLV4740-5W	Saddle and tightener with 64 mm clamp	454	1000	5.10	11.24
FLV4740-9W	Saddle and tightener with 76 mm clamp	454	1000	8.85	12.90
FLV4740-10W	Saddle and tightener less clamp	454	1000	4.10	9.04
FLV4740-15W	Saddle with mounting eye	454	1000	3.40	7.50
FLV4740-16W	Saddle with extension and 38 mm clamp	363	800	5.40	11.90
FLV4740-17W	Saddle with extension and 51 mm clamp	363	800	5.50	12.10
FLV4740-18W	Saddle with extension and 64 mm clamp	363	800	5.60	12.35
FLV4740-19W	Saddle with extension and 76 mm clamp	363	800	5.70	12.57
FLV4740-20W	Saddle with extension and shackle	363	800	4.60	10.15
RM4744	76 x 108 to 102 x 203 mm adjustable opening crossarm saddle	227	500	2.50	5.51
RM4760-W	Simple lift saddle	454	1000*	5.83	12.85
RM4760-1W	Double lift saddle	340	750*	6.40	14.11
RC400-1016	Single lift saddle with RITZGLAS® insulating tube	454*	1000*	8.50	18.70

* For each wire tong.



FLV4740-4W



FLV4740-10W



FLV4740-15W



FLV4740-16W



FLV4740-20W

G

Saddle Components

RC400-0073

RC400-0073



The saddle extension provide additional spacing between the sticks and the post, fixed to each other through the saddle. It has at one end preparation for coupling in the saddles through tear with appropriate geometry for fitting and drilling for installation of locking screw. At its other end, have a hole for fastening the pole clamp. Tool made of cast aluminum alloy with heat treatment so that the resistance is compatible with the efforts of its application.

RM1848-W

RM1848-W



The chain wheel tightener is a component of different models of saddles, it's responsible fastening the saddle to the pole and the final adjustment is possible by using the tightening wheel. The chain wheel tightener provides easy installation of the saddles, preventing it from sliding down or moving excessively, keeping it firm to its location. Haft manufactured in aluminum alloy, fork in micro-casting steel, stainless steel tightening wheel, welded link chain and safety pin.

RM1847

RM1847-3

RM1847-4

RM1847-6

RM1847



The length of the chain stretcher can be increased by using the chain extension for poles with larger diameters. Coupling made of heat treated aluminum alloy, attached to a chain made of steel and anticorrosive surface treatment. It has a safety pin also made of steel and with anti-corrosion treatment, which allows chain locking by the saddle.

RM4740

RM4740



The concrete pole saddle screw is simple and practical to install, this tool is inserted into one of the holes in the pole and fastened with a wing nut. Tool belonging to the wire tong saddles and components assembly. Constructed of galvanized steel, coupling and steel butterfly nut, it has a total length of 295 mm.

RM4740-14

RM4740-14



Wire tong saddle clevis is used to attach the wire tong butt-ring to a wire tong saddle, when used as an arm for the dual auxiliary arm, allowing the wire tong to rotate for attachment to the stirrup of the dual auxiliary arm. The piece structure consists primarily of a heat-treated aluminum alloy head, bronze alloy eye-screw, galvanized screws and lock washers, and a nylon-coated stainless-steel cable.

RM4741-1

RM4741-2

RM4741-3

RM4741-5

RM4741-3



The Pole Clamps are versatile and of great use, either in the distribution or transmission works, as they allow the fixing of rods in arrangements with other tools previously installed in the structure.

Constructed of cast aluminum, the pole clamp and microfused butterfly nut tightening to the tubes, plus a spring-loaded locking device that prevents spontaneous opening of the collar, providing firmness and safety. It has a smooth stainless steel internal coating to provide necessary adhesion without damaging the insulated tube.

RM4760-2

RM4760-2



The adapter, which converts a single saddle and single lift saddle into a double lift saddle for the mounting of two poles.

SADDLE COMPONENTS

Catalog Reference	Description	Rated Work Capacity		Approx. Weight	
		daN	lb	kg	lb
RC400-0073	Saddle extension	363	800	0,50	1,10
RM1848-W	915 mm chain stretcher	1134	2500	2,45	5,40
RM1847	457 mm chain extension	1134	2500	0,80	1,76
RM1847-3	915 mm chain extension	1134	2500	1,15	2,54
RM1847-4	1220 mm chain extension	1134	2500	1,40	3,09
RM1847-6	1830 mm chain extension	1134	2500	2.15	4.74
RM4740	290 mm long concrete pole saddle screw	-	-	0,82	1,81
RM4740-14	Wire tong saddle clevis	-	-	0,35	0,77
RM4741-1	38 mm clamp	-	-	0,80	1,76
RM4741-2	51 mm clamp	-	-	0,90	1,98
RM4741-3	64 mm clamp	-	-	1,00	2,20
RM4741-5	76 mm clamp	-	-	1,08	2,38
RM4760-2	Dual lift adapter	-	-	0,55	1,21

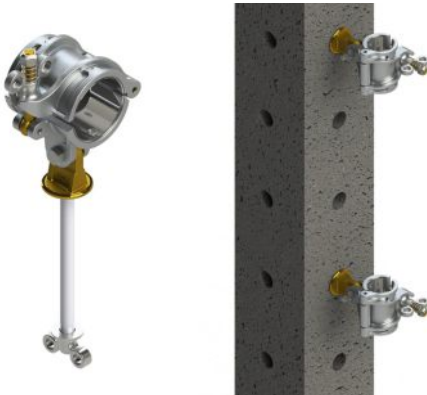

Saddle bolt for use on double-T concrete post with clamp

TOWER TYPE SADDLES

They are used to support the wire tong, boom, mast, block, or hoist to move insulator strings in the metal structure.

They are firmly coupled to the flanges of the metal structure angles by bolts and claws with wing nut.

Common Saddles

The RM4742 has a bronze shackle installed on the saddle body, which, through a swivel coupling, allows block anchorage.

The RM4742-1 to RM4742-4 models have clamps with varying diameters for safe and favorable coupling to the poles at any angle.

The RT400-1413 is similar to the RM4742, only differing in claw size, which were designed for larger corner flaps on larger metal structures.

Light Saddles

They have the same characteristics as the common saddle. However, they are made of aluminum alloy, which makes them more practical and easier to install.

Common saddles can be completely replaced by light saddles.



RM4742



RT400-1413

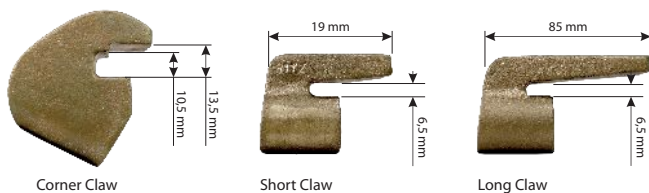

TOWER TYPE SADDLES

Catalog Reference	Description	Material	Connection Capacity	Rated Work Capacity		Approx. Weight	
				daN	lb	kg	lb
RM4742	Saddle without clamp	bronze	3" x 3" to 7" x 7"	454	1000	5.50	12.13
RM4742-1	Saddle with 38mm clamp	bronze				6.25	13.78
RM4742-2	Saddle with 51 mm clamp	bronze				6.30	13.89
RM4742-3	Saddle with 64 mm clamp	bronze				6.50	14.33
RT400-1413	Saddle without clamp, with 2 small and 2 big clamping jaws	bronze				5.80	12.79

DUAL AUXILIARY ARM

RC400-0075

Designed for replacement of utility poles, crossarms, or insulators. Like all RITZGLAS® tools it is lightweight and easy to assemble. In normal constructions or eccentric crossarms this tool can be used as a side arm.

The wireholders with 1" can be moved to minimize the transposition distance of the conductors from the insulators to this assembly as this tool is sufficiently sized to use as a lift arm using three wire tongs.

Insulating Length: 2.96 m

Approx. Weight: 17.50 kg (38.58 lb)



NOTE

When using the dual auxiliary arm (with voltages greater than 15 kV) or when supporting energized conductors in the rain or chance of rain, installing insulators (RM4805-7) to the dual auxiliary arm under the mounting wireholders is recommended to increase flow distance.

Wiping the insulating pole surface with treatment fabric (RM1904) on the dual auxiliary arm pole is recommended when it is installed at night or chance of rain conditions.

The dual auxiliary arm consists of the following tools:

- 01 Ø 64 mm RITZGLAS® pole combined with a saddle for utility pole mounting by a chain binder;
- 03 pcs fork-type wireholder of 25.4 mm (1") opening without insulator (RM4805-17);
- 02 wire tong stirrup (RC400-0331);
- 01 dual auxiliary arm "T" with insulator (RC400-0562)

Tools required for these types of assemblies:

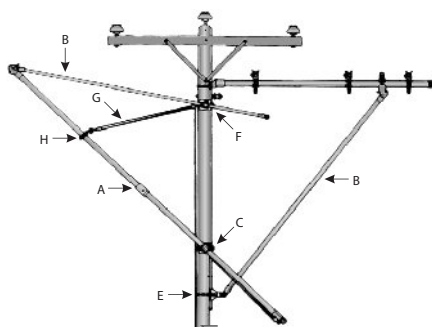

SIDE ARM

- (A) 01 wire tong RH4647-12;
- (B) 02 wire tongs RH4646-8;
- (C) 01 saddle with ext. and clamp 64 mm FLV4740-18W;
- (E) 01 saddle with mounting eye FLV4740-15W;
- (F) 01 saddle with ext. and 51mm clamp FLV4740-17W;
- (G) 01 double block RC400-0914;
- (H) 01 clamp for block RM1729-1.

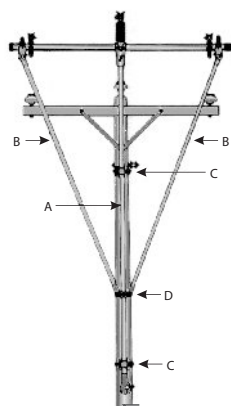

SIMULTANEOUS LIFT OF ASSEMBLY

- (A) 01 wire tong RH4647-12;
- (B) 02 wire tongs RH4646-8;
- (C) 02 saddles with extension and clamp, Ø 64 mm FLV4740-18W;
- (D) 01 64mm brace strap RM1728-5.

TOOL APPLICATION

RE400-0008 (1-1/2" without insulator) | **RM4805-15** (1" without insulator)

RE400-0009 (1-1/2" with insulator) | **RM4805-17** (1" with insulator)

These wireholders have 25.4 and 38 mm (1" and 1-1/2") openings and a counterbalanced device that automatically closes with conductor insertion and must be reversed to release the conductor.

These tools, with or without insulator, also have a Ø 64 mm clamp for coupling to the dual auxiliary arm crossarm.

RC400-0331 (Ø 64 mm)

An equipment that can be purchased separately as a replacement part or to be added to existing equipment. It is designed as a coupling point for the wire tongs used as braces of the dual auxiliary arm through its clamp. Besides being easy to install, it is made of aluminum alloy.

RM1728-5

It is used to attach the wire tong (which stands vertically as the mast supporting the dual auxiliary arm) to the wire tong eyes, which act as the braces of the set.

Made of aluminum alloy, the two halves of the strap form one piece, joined by two eye bolts.

Rated Work Capacity: 454 daN (1000 daN)

RC400-0562

FLV00714-2

It is specifically designed for use in the simultaneous lifting arrangement of the lifting assembly.



RM4805-17



RE400-0008



RC400-0331



RM1728-5



FLV00714-2



RC400-0562

PARTS AND COMPONENTS

Catalog Reference	Description	Approx. Weight	
		kg	lb
RM4805-15	1" fork-type wireholder with insulator	1.35	2.98
RM4805-17	1" fork-type wireholder without insulator	0.90	1.98
RE400-0008	1-1/2" fork-type wireholder without insulator	1.30	2.87
RE400-0009	1-1/2" fork-type wireholder with insulator	1.75	3.86
RC400-0331	Stirrup for brace (Ø 64 mm)	0.94	2.09
RM1728-5	64mm brace strap	1.50	3.31
FLV00714-2	Eye head without insulator	1.95	4.30
RC400-0562	Eye head with insulator	2.40	5.29

AUXILIARY CROSSARMS

The RH4862-6, RH4862-8, and RH4862-51 Auxiliary crossarms are used for operations to replace medium voltage overhead short span insulators or utility poles up to 15 kV phase/phase. It must be complemented with two saddles (FLV4740-5W) to install the auxiliary crossarm mast to the pole. Saddles must be purchased separately.

It has a load capacity of 272 daN (600 lb), with four conductors in balance and 68 daN (150 lb), in each wireholder, at unbalanced condition.



RH4862-6



FLV05613-1



RM4805-16

RH4862-6 - AUXILIARY CROSSARMS

Item	Quant.	Catalog Reference	Description	Approx. Weight	
				kg	lb
01	01	FLV21310-1	Ø 64 mm x 1.78 m Crossarm pole insulating length	5.10	11.24
02	01	FLV17928-1	Ø 64 mm x 1.35 m Mast pole insulating length	2.82	6.22
03	01	FLV05613-1	Auxiliary arm "T"	1.30	2.87
04	04	RM4805-16	C-type wireholder without insulator	1.08	2.38

RH4862-8 - AUXILIARY CROSSARMS

Item	Quant.	Catalog Reference	Description	Approx. Weight	
				kg	lb
01	01	FLV21310-2	Ø 64 mm x 2.39 m Crossarm pole insulating length	5.10	11.24
02	01	FLV17928-1	Ø 64 mm x 1.35 m Mast pole insulating length	2.82	6.22
03	01	FLV05613-1	Auxiliary arm "T"	1.30	2.87
04	04	RM4805-16	C-type wireholder without insulator	1.08	2.38

RH4862-51 - MAST & BRACES

Item	Quant.	Catalog Reference	Description	Approx. Weight	
				kg	lb
01	01	FLV17928-2	Ø 64 mm x 2.83 m Mast pole insulating length	2.82	6.22
02	02	FLV03457-13	Ø 38 mm x 2.03 m Support insulating length	6.86	15.12
03	02	RM4741-3	Ø 64 mm clamp	1.00	2.20
04	01	RM1728-5	Ø 64 mm for Brace Strap	1.50	3.31
05	01	FLV05613-1	Auxiliary arm "T"	1.30	2.87

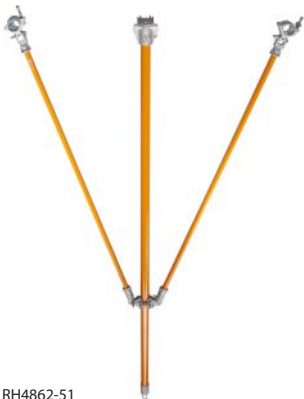

RH4862-51

ACCESSORY

Catalog Reference	Description	Approx. Weight	
		kg	lb
RC400-0268	Roller wireholder for mounting on the auxiliary crossarm of truck cranes or similar vehicle, 1-3/4" opening	1.90	4.19
RC400-0269	Roller wireholder for installation on auxiliary crossarm with insulator RM4805-7, 2" opening	2.50	5.51



RC400-0268



RC400-0269

EXTENSION ARM

They are designed for voltages up to 15 kV and are typically used for switching conductors or insulators. However, they can also be used at voltages up to 34.5 kV provided insulators (RM4805-7) are installed in the wireholders.

It is a tool attached under the crossarm so that approximately 3/4 of its length exceeds that crossarm to allow the conductors to be transposed into their wireholders.



Catalog Reference	Ø (mm)	Insulating Length (m)	Number of Wireholders per Product	For Crossarm with Maximum Dimension (mm)	Maximum Vertical Capacity per Wireholder		Approx. Weight	
					daN	lb	kg	lb
RH4800-60	64	1.43	1	95 x 120	68	150	5.80	12.79
RH4800-72	64	1.74	2	95 x 120	68	150	7.40	16.31
RT403-2417	64	1.74	2	95 x 120 e 152 x 152	68	150	6.30	13.90
RC400-1310	76	1.74	2	95 x 120 e 152 x 152	136	230	10.90	24.00

AUXILIARY CROSSARM SUPPORT FOR AERIAL DEVICE



It is designed for fast and safe operation, with the aid of an aerial device, to replace crossarms, insulators or poles in short spans of live overhead networks up to 34.5kV.

It has clamps for fitting and adjusting auxiliary \varnothing 64mm pipe crossarms. It is also adaptable in various square or rectangular sections of aerial device.

Its installation and removal is simple and the tool can be easily stored and transported as it is a compact and lightweight solution for the type of operation it is intended for.



Catalog Reference	Rated load capacity (kgf/lbf)*	Man basket minimum section (mm)	Max. perimeter of man basket section (mm)	Approx. Weight	
				kg	lb
FLV30045-1	280 / 617	128 width 183 height	910	8.70	19.20

* Attention should be paid to air basket capacity and restricted to it if it is lower.

TEMPORARY CONDUCTOR SUPPORT

RC400-0517

The conductor support can be attached to crossarms, with sizes 82 x 102 mm to 152 x 152 mm. The C-shaped clamp as well as the wireholder is made of heat-treated aluminum alloy and fixed to the RITZGLAS® tube. It can be installed with the hot stick.



RC400-0517

FLV30058-1

The conductor support pole (used for lifting conductor cables through its upper head by its lifting wireholder) is adaptable to metal post straps through support with a lower blade.



FLV30058-1

RC400-1509

RH4809-W

They are used to support energized distribution conductors during pole replacement, repair, or pin or top insulators replacement.

They are equipped with a pole chain stretcher, over \varnothing 356 mm, and lifting wireholders for conductors up to \varnothing 25.4 mm (for RC400-1509 with two units and RH4809-W with one unit).

When using temporary support with voltages greater than 15 kV or when supporting energized conductors in the rain (or chance to rain), mounting insulators (RM4805-7) is recommended as additional protection.



RC400-1509

RT400-1939

RT400-1940

These two temporary support models have the same functions as RC400-1509 and RH4809-W. The difference is the pole mounting system, which in this case coma nylon tie tensioner. (RT400-2007)

The same recommendations for using the insulator (RM4805-7) and the rated workload also prevail for these two models.



RH4809-W



RT400-1940

RT400-2272

The insulator change support is designed for special applications for distribution insulator change, whose conductors are angled.

Used in combination with a nylon strap hoist, it sustains the conductor under mechanical stress during the insulator change and assists the conductor back to its original location.

With this tool there is no need to use round covers or blankets on the pole to insulate the hoist.

To insulate the hoist with a nylon tie, two insulating rods (RC400-1175 or RC400-2399 or RC400-2400) are used, connecting their hooks to the wire grips and their eyes to the hooks of the hoist.

This equipment was made with \varnothing 64 mm RITZGLAS® tube, insulating length 0.15 m and working length 0.40 m.



RT400-2272

RT400-2007

It is coupled to the pole using the nylon tie tensioner (RT400-2007).



RT400-2007

TYPICAL APPLICATIONS

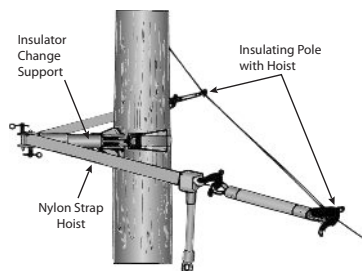

In this arrangement, the insulator change bracket is installed on the opposite side of the conductor and is used when a short distance from the conductor in relation to the post is required.

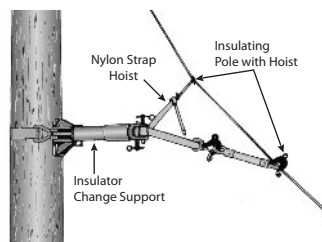

In this other arrangement, the insulator change bracket is installed on the conductor side in order to obtain a greater distance from it.

TEMPORARY SUPPORT

Catalog Reference	Description	Rated Work Capacity		Approx. Weight	
		daN	lb	kg	lb
RC400-0517	Conductor bracket, with crossarm mounting and \varnothing 32 mm x 200 mm insulating length	68	150	2.20	4.85
FLV30058-1	Conductor support pole, adaptable to the post through the support with a blade and \varnothing 38 mm x 250 mm insulating length	38	83,78	1.96	4.32
RC400-1509	Conductor's bracket, with pole mounting through chain stretcher, mounted to \varnothing 64 mm x 1.11 m insulating length RITZGLAS® tube, with wireholders	68	150	7.70	16.98
RH4809-W	Conductor's bracket, with pole mounting through chain stretcher mounted on \varnothing 64 mm RITZGLAS® tube, with 1 wireholder. Spacing between clamp and pole mounting: 0.76 m	68	150	6.30	13.89
RT400-1939	Pole-mounted conductor's support via nylon tie-pole, mounted on \varnothing 64 mm x 1.11 m insulating length RITZGLAS® tube, with 2 wireholders	68	150	8.10	17.85
RT400-1940	Conductor bracket, with pole mounting using a nylon tie tensioner, mounted on a \varnothing 64 mm RITZGLAS® tube, with 1 wireholder. Spacing between clamp and pole mounting: 0.76 m	68	150	6.40	14.00
RT400-2272	Support for insulator change, with pole mounting system through a nylon tie tensioner. Insulating length: 0.15 m Work length: 0.40 m	907	2000	5.90	13.00
RT400-2007	1.20 m nylon tensioner for replacement of insulator change support RT400-2272	907	2000	1.40	3.00

HOT STICK TENSION PULLER

It is intended for strain and support of energized conductors. The hot tension puller stick can also be used during insulator replacement, conductor splicing work or for a number of works on energized installations.

Its basic construction (combining Ø 38 mm RITZGLAS® tube and single body strain device) makes it a versatile and complete tool.

It has non-rotating forged steel hooks and safety lock and eyebolts, which allow the quick and easy installation of the insulated strain jack manually or by means of an insulating pole.

The safety locks turn 135° to the right and left from the closed position.

The drive lever has an eye for insertion of the stick and allows operation from distance.

Catalog Reference	Voltage (kV)	Max Load Capacity		Work Length Between Hooks (m)	Maximum Tool Displacement (m)	Insulating Length (m)	Approx. Weight	
		daN	lb				kg	lb
RC400-0574	34.5	1814	4000	Minimum: 1.64 Maximum: 1.94	0.30	0.79	6.40	14.11
RC400-0575	69.0			Minimum: 1.84 Maximum: 2.14			6.50	14.33

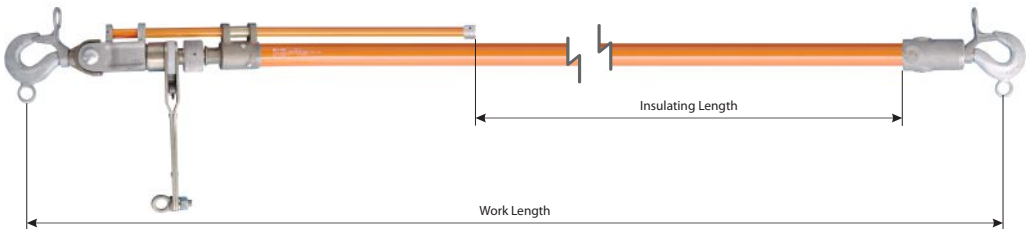



SYMMETRICAL TENSION PULLER

Fitted with a hook, the Symmetrical Tension Puller is a removable suspension device used to take off the mechanical tension of conductors and used to remove 254mm insulator chains. Used in overhead networks in the distance method.

Symmetrical Tension Puller made of Ø32mm RITZGLAS® tube, aluminum hook jaw, central support in white nylon and steel fixing hooks.

Catalog Reference	Insulating Length (m)	Working Length (m)		Rated Work Capacity		Approx. Weight	
		Minimum	Maximum	daN	lb	kg	lb
FLV19769-1	0.90	1.13	1.35	1700	3750	7.00	15.43

STRAIN LINK STICK

It is used in angle anchor structures as insulation between blocks and wire grips. Large-span conductor loads and "H" structures sometimes exceed the safe capacities for the wire tong. To supplement the wire tong, attach the strain link stick to the conductor. This stick is also used to support the center conductor in "H" type structures when changing insulators or crossarms.

Constructed with RITZGLAS® insulating tube and aluminum alloy fittings, for better mechanical strength and lightness ratio, the swivel eye has bearings for smooth and perfect rotation. The jaw edges of this tool are rounded to prevent damage to conductors.

To meet a higher demand for tasks that require loads or varieties of wire size, this tool is built in four head sizes and variations in pipe lengths.

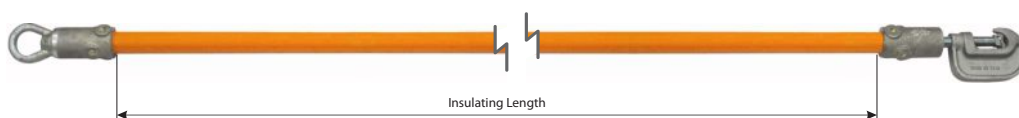

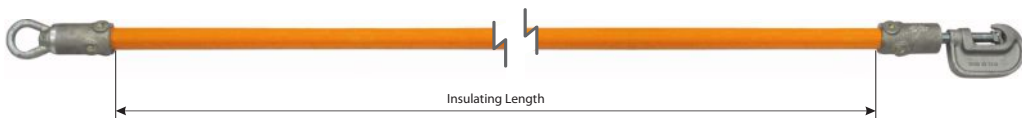

STRAIN LINK STICK

Catalog Reference	Dimensions		Jaw Opening (mm)		Rated Work Capacity		Storage (optional)	Approx. Weight	
	Ø (mm)	Insulating Length (m)	Minimum	Maximum	daN	lb		kg	lb
RC400-0814	32	1.70	5.60	19.00	1588	3500	FLV18339-2	2.30	5.07
RC400-0815	32	2.30	5.60	19.00	1588	3500	FLV18339-3	2.60	5.73
RC400-0816	32	2.90	5.60	19.00	1588	3500	FLV18339-4	2.90	6.39
RC400-0817	32	3.60	5.60	19.00	1588	3500	FLV18339-5	3.20	7.05
RC400-0818	32	4.20	5.60	19.00	1588	3500	FLV18339-14	3.60	7.94
RH4715-1	32	0.50	5.60	19.00	1588	3500	FLV18339-15	1.70	3.75
RH4715-2	32	1.10	5.60	19.00	1588	3500	FLV18339-1	2.00	4.41
RH4716-1	38	0.45	11.20	27.00	2948	6500	FLV18339-15	2.90	6.39
RH4716-2	38	1.05	11.20	27.00	2948	6500	FLV18339-1	3.30	7.28
RH4716-3	38	1.65	11.20	27.00	2948	6500	FLV18339-2	3.70	8.16
RH4716-4	38	2.25	11.20	27.00	2948	6500	FLV18339-3	4.15	9.15
RH4716-5	38	2.85	11.20	27.00	2948	6500	FLV18339-4	4.60	10.14
RH4716-6	38	3.55	11.20	27.00	2948	6500	FLV18339-5	5.00	11.02
RH4717	38	1.05	18.30	38.00	2948	6500	FLV18339-12	3.40	7.50
RH4717-1	38	1.65	18.30	38.00	2948	6500	FLV18339-13	3.80	8.38
RH4718	38	1.05	25.40	63.50	2948	6500	FLV18339-12	4.30	9.48
RH4718-1	38	1.65	25.40	63.50	2948	6500	FLV18339-13	4.70	10.36
RH4718-2	38	2.25	25.40	63.50	2948	6500	FLV18339-4	5.10	11.24
RH4718-3	38	2.85	25.40	63.50	2948	6500	FLV18339-4	5.60	12.35
RH4718-4	38	3.55	25.40	63.50	2948	6500	FLV18339-14	6.00	13.23

SPIRAL LINK STICK

It is used in situations where the work areas in the structure have reduced spaces for the electrician to install the strain link stick safely. An eye near the spiral hook allows the electrician to install the spiral link pole into the conductor with the aid of a hot stick.

It is made with a RITZGLAS® tube, a special, hot-dip galvanized, sturdy, spiral-shaped steel hook suitable for the workloads required for conductors with sizes up to 1510.5 kcmil ACSR (approx. Ø 38 mm) and aluminum alloy heads.

The swivel eye also has bearing for smooth rotation.

Catalog Reference	Dimensions		Rated Work Capacity		Storage (optional)	Approx. Weight	
	Ø (mm)	Insulating Length (m)	daN	lb		kg	lb
RH4722		0.29			FLV18339-15	1.00	2.20
RC400-0812	32	0.96	1588	3500	FLV18339-12	2.30	5.07
RC400-0813		1.57			FLV18339-2	2.60	5.70

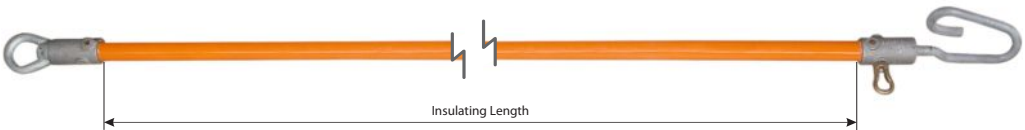

ROLLER LINK STICK

It is used to move and keep the energized conductor in the middle of the span in order to obtain more work space when changing the pole.

When placed on the conductor, it is supported by the pole roller for easy movement along the line with the aid of a rope or block attached to the eye, pulled by the electrician from the ground.

The roller head of this tool allows a maximum conductor size of up to 605 kcmil ACSR (Ø 24 mm approx.).

Constructed with RITZGLAS® tube, its bronze alloy hook and roller is installed on a threaded pin, responsible for its rotation for closing and opening the jaw, where the conductor is secured. It has a heat-treated aluminum alloy heads and a forged steel swivel ring with rolling for smooth rotation.

Catalog Reference	Dimensions		Rated Work Capacity		Storage (optional)	Approx. Weight	
	Ø (mm)	Insulating Length (m)	daN	lb		kg	lb
RH4714-4	32	1.13	454	1000	FLV18339-12	2.48	5.47
RH4714-6		1.74					

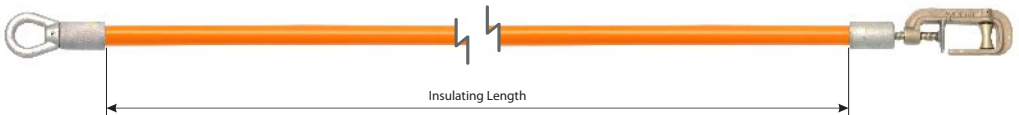

STRAIN POLE CLEVIS-EYE / CLEVIS-CLEVIS

They are designed for use in single or multiple suspension or anchor strings. Also used in V-strings, directly coupled to the yoke plate hole in order to relieve the load of the two strings simultaneously.

Built with RITZGLAS® tubes, they feature non-swiveling aluminum alloy eye heads and adapt to a wide range of aluminum sheet yoke shapes through the bronze alloy clevis heads.

CLEVIS-EYE STRAIN POLE

Catalog Reference	Description	Ø (mm)	Insulating Length (m)	Rated Work Capacity		Approx. Weight	
				daN	lb	kg	lb
RC400-0612	With bronze alloy clevis head, 27 mm internal opening and locking eye pin	51	2.52	2948	6500	6.10	13.45
RC400-0613	With bronze alloy clevis head, 27 mm internal opening and locking eye pin		3.05			6.70	14.77

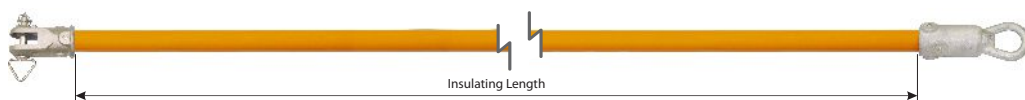

CLEVIS-CLEVIS STRAIN POLE

Catalog Reference	Description	Ø (mm)	Insulating Length (m)	Rated Work Capacity		Approx. Weight	
				daN	lb	kg	lb
FLV29023-1	With bronze alloy clevis head, 27 mm internal opening and locking eye pin	51	3.79	5443	12000	9.30	20.5
FLV29023-2	With bronze alloy clevis head, 27 mm internal opening and locking eye pin		4.09			9.70	21.40
FLV29023-3	With bronze alloy clevis head, 27 mm internal opening and locking eye pin		3.94			9.50	20.90
FLV29023-4	With bronze alloy clevis head, 27 mm internal opening and locking eye pin		1.84			6.90	15.20
FLV29023-5	With bronze alloy clevis head, 27 mm internal opening and locking eye pin.		4.29			9.90	21.80

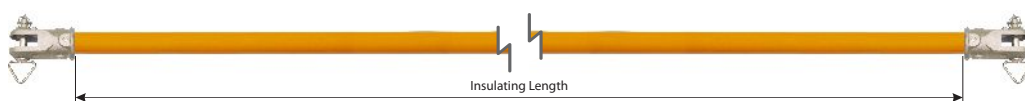

ADJUSTABLE STRAIN POLES

It is made with Ø 51 mm RITZGLAS® tube and has 6 stainless steel cross-pins (5 working and 1 locking), at 152 mm intervals to support the adjustable pole clamp on the live end.

The 5-pin arrangement allows yoke displacement to a maximum length of 608 mm.

The hot-end yokes for suspension or anchor insulator strings are coupled to the Strain Poles through their adjustable pole clamps. The pole clamps can be adjusted manually or with a Hot Stick. The adjustable hook assembly can be used directly on the Strain Pole to lift the conductor, where yoke use is not required.

On the de-energized side, a special 305 mm long steel bolt allows a uniform straining of the assembly through ratchet wrenches and trunnions.

It also has strain jacks of different lengths and the adjustable pole clamp or adjustable hook assembly can be purchased separately or as spare parts.

Trunnions and ratchet wrench can also be purchased separately.

This tool is essential in a wide variety of tasks when servicing high voltage and extra high voltage transmission lines. Adjustable strain poles can be used with adjustable pole clamp (RE401-0138) or adjustable hook assembly (RM4724-1).

COMPOSITION OF THE SET

Adjustable strain poles (RC401-2144 to RC401-2149 series) are supplied with the following components:

- 01 Ø 51 mm Strain Pole with clevis head;
- 01 Adjustable pole clamp RE401-0138;
- 01 Strain Jack RE401-1998 (305 mm length);
- 01 Strain Jack Locking Pin RE401-1510;
- 01 Cotter Pin FLV11384-1;

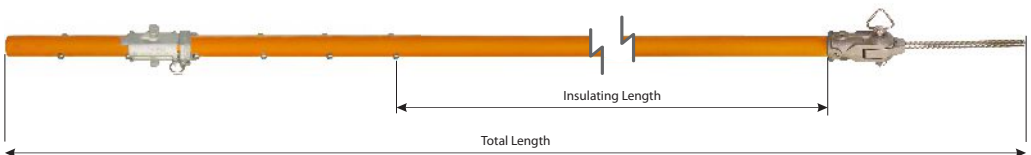
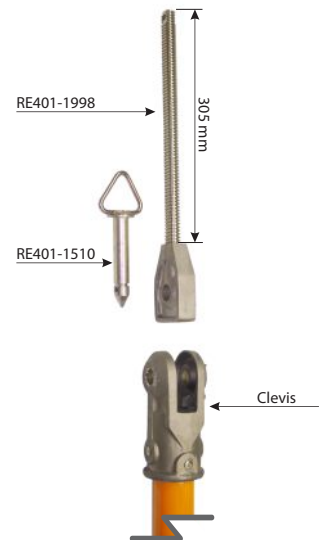

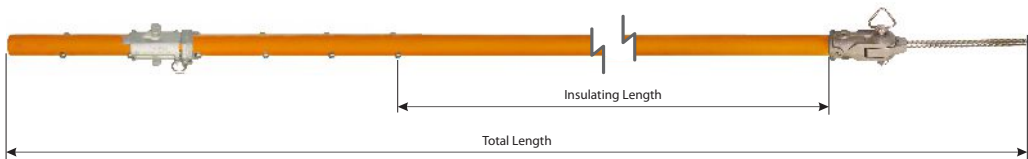

ADJUSTABLE STRAIN POLES

Catalog Reference	Maximum Use Voltage (kV)	Insulating Length (m)	Total Length (m)	Storage (optional)	Approx. Weight	
					kg	lb
RC401-2144	72.5	0.91	2.29	FLV18339-13	8.50	18.74
RC401-2145	169	1.22	2.60	FLV18339-3	8.90	19.62
RC401-2146	242	1.60	2.98	FLV18339-4	9.30	20.50
RC401-2147	302	2.13	3.51	FLV18339-5	10.00	22.05
RC401-2215	362	2.60	3.98	FLV18339-14	11.30	24.91
RC401-2148	552	3.43	4.81	FLV18339-16	11.50	25.35
RC401-2149	765	4.57	5.95	FLV18339-17	13.00	28.66

Rated Work Capacity: 3402 daN (7500 lb).

ACCESSORIES

Catalog Reference	Description	Approx. Weight	
		kg	lb
RE401-0138	Adjustable pole clamp Ø 51 mm	0.70	1.54
RE401-1998	Strain Jack 305 mm long	1.30	2.87
RV401-0157	Strain Jack 610 mm long	1.80	3.97
RV401-0158	Strain Jack 915 mm long	2.30	5.07
RE401-1510	Steel Pin to lock clevis bolt	0.30	0.66

SECTIONAL STRAIN POLE (WITH SPLICE)

RC401-0758

Designed to withstand the mechanical strain of conductor cables while maintaining suspension or anchor insulator strings where their lengths differ from conventional standards.

This pole consists of three parts: hot-end pole (energized), cold-end pole (de-energized), and the fiberglass splice, which is the central tube responsible for joining the live and cold end poles.

Constructed with Ø 51 mm RITZGLAS® tube, each has a clevis-type bronze alloy head for connection to the yokes. The fiberglass splice is manufactured by a special process, with Ø 76 mm exterior reinforced fiberglass, and has equidistant holes every 100 mm, making it possible to assemble the hot-end and cold-end poles, within pre-established lengths.

The poles also allow combinations with strain jacks in lengths 305, 610 and 915 mm for additional gain in overall assembly length.

Hot or cold-end poles, fiberglass splice, strain jack, or cotter pins can be purchased separately as spare parts.

Length: minimum 3.15 m | maximum 3.75 m

Rated Work Capacity: 4536 daN (10000 lb)

Approx. Weight.: 13.90 kg (30.64 lb)

NOTE

Although the splicing fiberglass splice is manufactured to a standard length of 1.12 m, dead and hot-end poles can be purchased with special lengths to suit the types and strains of each company's networks. For such supplies, which will depend on the arrangements of the strings, their design must be sent to our engineering department for technical feasibility analysis.



COMPOSITION OF THE SET

- 01 RITZGLAS® hot-end pole, with clevis-type bronze alloy head and steel pin and cotter pin.
- 01 RITZGLAS® cold-end pole, with clevis-type bronze alloy head and steel pin and cotter pin.
- 01 fiberglass splice, 1.12 m long, and two sets of steel pins and cotter pins.

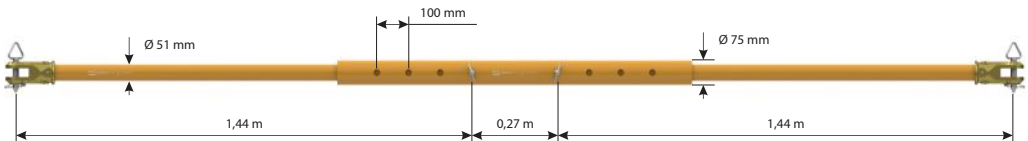

LIGHT-WEIGHT STRAIN CARRIER

FLV17450-1

It is designed for Grosbeak conductors, up to 636 MCM (Ø 25.15 mm), for changes of single strings of 69 to 145 kV anchorage and 110 to 145 kV suspension on live lines.

The excellent mechanical characteristics of the RITZGLAS® tube allow the strain pole diameter to be reduced to just 32 mm (1-1/4"), with consequent proportional reduction of metal parts, making it a light and practical set for easy handling and transport.

Metal tools that work on the de-energized side are used for both anchoring and suspension, providing versatility to the assembly and making it more economical and attractive in terms of cost effectiveness.

Rated Work Capacity: 2948 daN (6500 lb)

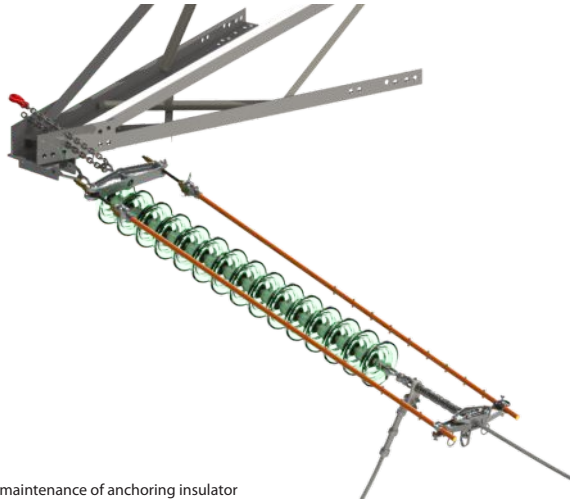

Used in the maintenance of anchoring insulator

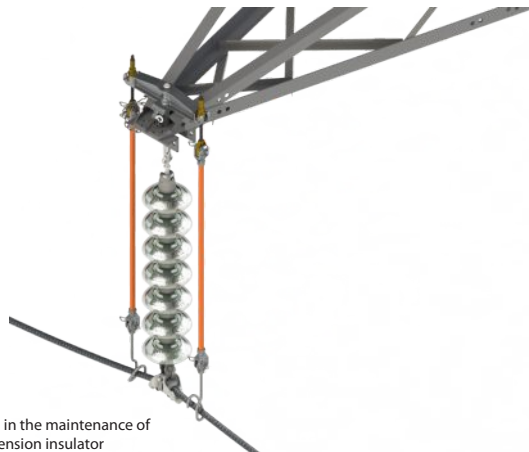

Used in the maintenance of suspension insulator

G

COMPOSITION OF THE ANCHOR SET

Catalog Reference	Description	Quantity	Approx. Weight	
			kg	lb
FLV13352-1	Cold-end yoke with 1400 mm string	01	8.10	17.86
RE401-1998	305 mm long strain jacks with	02	1.30	2.87
RE401-2068	Small trunnion	02	0.83	1.83
FLV13780-1	Ø 32 mm RITZGLAS® Insulating Strain Poles, 2.70 m total length, with cast aluminum clevis for strain jack coupling and 10 pins, 152 mm spacing for hot-end yoke coupling	02	4.10	9.04
FLV12192-1	Cast aluminum alloy hot-end yoke with 2 pairs of ACSR cable clamps, minimum 2 AWG (Ø 6.6 mm) to maximum 636 MCM (Ø 25 mm)	01	5.80	12.79
Total			20.13	44.39

COMPOSITION OF THE SUSPENSION SET

Catalog Reference	Description	Quantity	Approx. Weight	
			kg	lb
FLV13352-1	Cold-end yoke with 1400 mm string	01	8.10	17.86
RE401-1998	305 mm long strain jacks with	02	1.30	2.87
RE401-2068	Small trunnion	02	0.83	1.83
FLV13130-1	Ø 32 mm RITZGLAS® Insulating Strain Poles, total length 1.46 m, with die-cast aluminum clevis at both ends	02	2.60	5.73
FLV13356-1	Cast aluminum alloy support for coupling to the tower crossarm, hook string, and safety lock	01	3.40	7.50
FLV13006-1	Spiral Hook Parts of special heat treated steel, 695 mm length with eye for coupling to the clevis-clevis strain pole	02	2.30	5.07
FLV13006-2	Spiral Hook Parts of special heat treated steel, 615 mm length with eye for coupling to the clevis-clevis strain pole	02	2.00	4.41
FLV13006-3	Spiral Hook Parts of special heat treated steel, 555 mm length with eye for coupling to the clevis-clevis strain pole	02	1.80	3.97
Total			22.30	49.16



FLV13352-1



FLV13356-1



FLV12192-1

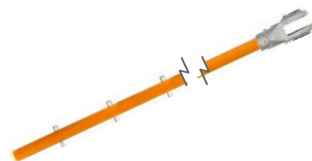

FLV13780-1

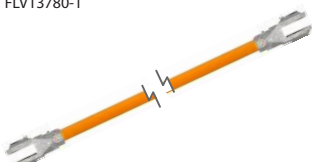

FLV13130-1

APPLICATION OF EACH TOOL

1. FLV13352-1 (cold-end yoke)

It is applied to anchor and suspension strings.

In anchor strings, it is coupled to the tower crossarm, with the string.

In the suspension string it is coupled to the tower crossarm with the aid of the support (FLV13356-1).

2. FLV13356-1 (support)

It is supported and mounted to the end of the tower crossarm to support and couple the cold-end yoke (FLV13352-1) in suspension string changes.

3. FLV12192-1 (hot-end yoke)

It couples directly to the cable, eliminating the use of wire grip when replacing the anchor string.

4. FLV13780-1 (insulating strain pole)

The cold-end yoke is attached to the strain jack. The 10 pairs of hot-end pins support and couple the yoke without requiring an adjustment pole clamp when changing the insulator string in the anchor structure.

5. FLV13130-1 (insulating strain pole)

With the Strain Jack (RE401-1998) coupling at one end and the Spiral Hook (FLV13006-1, FLV13006-2, FLV13006-3) at the other end, this tool is used to support the cable in suspension string exchange.

STRAIN POLE

Catalog Reference	Insulating Length (m)	Working Length (m)	
		Minimum	Maximum
FLV13780-1	1.09	1.16	2.53
FLV13130-1	1.22	1.45	1.45

NOTE

Poles in other lengths can be purchased on request

6. RE401-1998 (strain jack)

Attachable to the strain pole (FLV13780-1) by the eye yoke system and to the dead yoke (FLV13352-1) through the small trunnion (RE401-2068).

NOTE



Bolts in other lengths can be purchased on request.

7. RE401-2068 (small trunnion)

Threaded into the strain jack (RE401-1998) with the aid of the ratchet wrench (RM1948-3) to tension the conductor, transferring the string load to the strain set.

8. FLV13006-1 / FLV13006-2 / FLV13006-3 (spiral hook)

Coupled to the Strain Pole (FLV13130-1), the spiral hook secures the conductor to support it in the suspension string change. Each of the 3 hook sizes is used according to the length of the hot-end hardware of the insulator string.

9. RM1948-3 (ratchet wrench)

Although this tool is not included in the strain set, we recommend purchasing it for single trunnion application (RE401-2068).

10. FLV19286-1 (bag)

Used for storage and transporting of strain pole FLV13780-1.

11. FLV19286-2 (bag)

Used for storage and transporting of strain pole FLV13130-1.

12. ATR09962-1 (multi-purpose handbag)

Used for storage and transport of the other components of the set.



RE401-1998



RE401-2068



FLV13006-1



FLV13006-2



FLV13006-3



RM1948-3

DISTRIBUTION STRAIN CARRIER

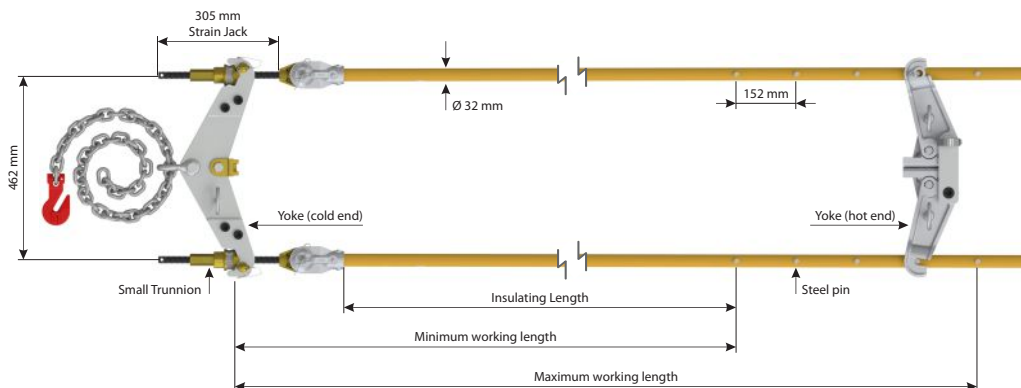

The RC401-0411 and RC401-0410 Distribution Double Strain Carriers relieves the tension of the anchor insulator string to allow it to be removed from the energized line. It has a yoke on the hot-end equipped with jaws that are mounted to the conductor by compression, tightening each time the strain load increases.

These jaws are designed to be mounted to conductors with \varnothing 7.40 to 20.50 mm (2 to 397.5 ACSR). The other end of the assembly is equipped with yoke and hook string for anchoring to the structure. Special 305 mm long steel bolts with small trunnion allow for even strain of the assembly.



FLV12192-1



FLV12239-1



RM1942



COMPOSITION OF THE SET

Distribution Double Strain Carriers are supplied with the following components:

- 02 \varnothing 32 mm RITZGLAS® Poles, for adjustments to the yoke through the 05 steel pins in each pole and adjusting every 152 mm;
- 01 Yoke FLV12192-1 for hot-end mounting;
- 01 Yoke FLV12239-1 for anchoring the assembly to the structure through the chain (RM1942) accompanying the assembly;
- 02 Strain Jacks RE401-1998 (305 mm);
- 02 Small trunnion RE401-2068.

Strain Jacks, trunnions, and yokes can be purchased separately as spare parts.

DISTRIBUTION STRAIN CARRIER

Catalog Reference	Strain Pole	Working Length (m)		Approx. Weight	
		Minimum	Maximum	kg	lb
RC401-0411	FLV12240-2	1.10	1.70	26.70	58.86
RC401-0410	FLV12240-1	1.70	2.32	27.30	60.19

Rated working capacity is 2948 daN (6500 lb) for distribution strings between 69 and 145 kV.

STRAIN POLE

Catalog Reference	Insulating Length (m)	Overall Length (m)	Approx. Weight	
			kg	lb
FLV12240-2	0.97	1.83	6.20	13.67
FLV12240-1	1.59	2.44	5.40	11.90

TWO-POLE STRAIN CARRIER

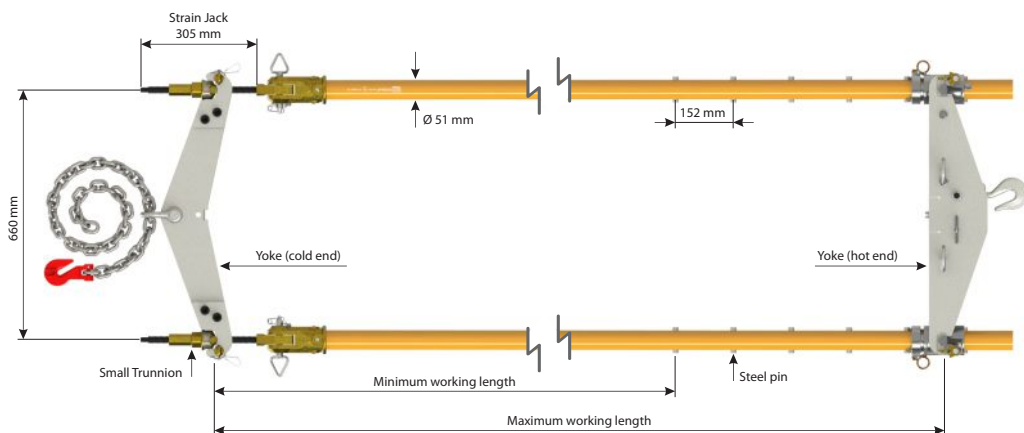

The Two-pole Strain Carrier (RC401-2174 to RC401-2179 series) relieves the mechanical strain of the insulator string so it can be removed from the energized line for to be changed, either in single or multi-insulator string according to the string arrangement hardware.

Strain Poles are used with adjustable pole clamps and yokes, with trunnions and strain jacks.

Through the adjustable pole clamp the energized side suspension or anchor yokes are coupled to the Strain Poles. The pole clamps can be adjusted manually or with a Hot Stick.

The energized side yoke includes a steel hook.

The yokes are constructed of rolled aluminum sheets and include a hook string for anchoring to the structure.

Strain Jacks, adjustable pole clamps, trunnions or yokes can be purchased separately as replacement parts.

COMPOSITION OF THE ASSEMBLY

The above mentioned Double Strain Carriers are supplied with the following components:

- 02 Ø 51 mm RITZGLAS® Strain Poles, with clevis heads and pins and cotter pins;
- 01 Yoke RC401-1721 for anchoring to the structure (including its respective string Rm1942);
- 01 Yoke RC401-1720 for hot-end mounting;
- 02 strain jacks RE401-1998 (305 mm);
- 02 Adjustable pole clamp RE401-0138;
- 02 Small Trunnions RE401-2068;
- 01 Socket for Yoke RC401-1720



RC401-1721



RM1942



RC401-1720

TWO-POLE STRAIN CARRIER

Catalog Reference	Strain Pole	Working Length (m)		Approx. Weight	
		Minimum	Maximum	kg	lb
RC401-2174	RC401-2144	1.09	1.88	33.70	74.30
RC401-2175	RC401-2145	1.40	2.19	34.00	74.96
RC401-2176	RC401-2146	1.78	2.57	34.50	76.06
RC401-2177	RC401-2147	2.32	3.10	35.20	77.60
RC401-2216	RC401-2215	2.78	3.57	36.20	79.81
RC401-2178	RC401-2148	3.61	4.40	36.70	80.91
RC401-2179	RC401-2149	4.75	5.54	38.20	84.22

The rated working capacity is: 6804 daN (15000 lb)

AUXILIARY STRAIN CARRIER

The Auxiliary Strain Carrier is a lightweight, portable tool designed for quick replacement of damaged insulators in **de-energized** suspension strings, especially when the number of damaged insulators does not justify the removal and lowering of the entire string for ground replacement.



SAFETY PROCEDURE

When changing insulators in the de-energized suspension chains, handling the Auxiliary Strain Carrier requires special attention about its installation in the network, in order to avoid accidents

1. This tool is only used in de-energized networks.
2. Prior to the installation of the auxiliary strain pole, the electrician will first need to install a complete strain set (yoke + strain pole) and suitable for the insulator string in order to relieve the mechanical strain of the string and allow insulator decoupling.
3. After that, the nut and the auxiliary strain pole will be mounted on the insulator directly above the one to be replaced (changing one insulator at a time).
4. When coupling, make sure that the insulator cap is resting only on the upper base of the yoke when using model FLV11537-1, or on the upper base of the nuts when using models FLV30577.

FLV11537-1

It has two Yokes made of cast aluminum alloy, in addition to two trunnions and two tensioning screws.

Rated Work Capacity: 600 daN (1322 lb)

Approx. Weight: 8.15 kg (17.95 lb)



FLV11537-1

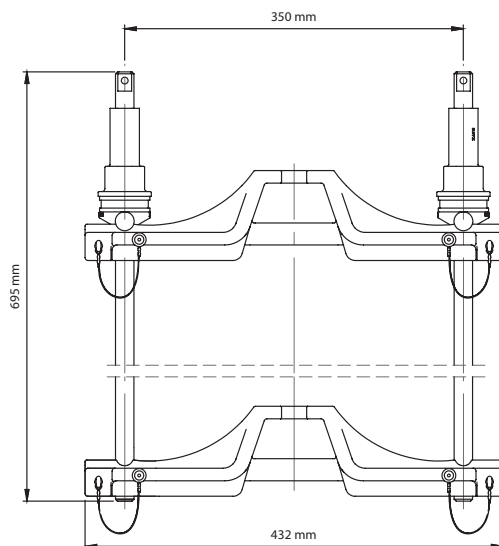

FLV30577-3

It has two Yokes that are coupled to the insulator cap with the help of shoes manufactured according to the insulator model (purchased separately), made of cast aluminum alloy, in addition to two trunnions and two tensioning screws.

Rated Work Capacity: 600 daN (1322 lb)

Approx. Weight: 10.40 kg (22,92 lb)

FLV30577-4

10.20 kg (22.48 lb)

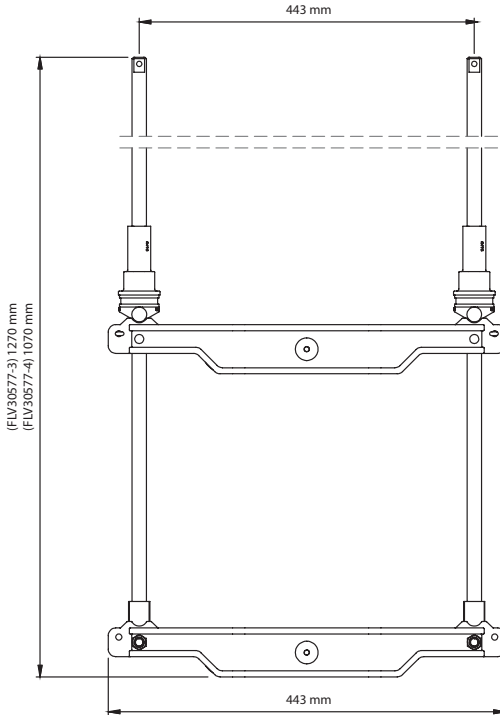

FLV30577



NOTE

Removable shoes (purchased separately) are changed to fit different types of insulators. When the models available in this catalog do not meet the insulator specifications, the insulator drawing must be made available for evaluation by our engineering department for the development of the appropriate shoes.

SHOES

Catalog Reference	Isolator Model	Diameter (mm)	Pitch (mm)
FLV30669-1	F300 PU C 195	300	195
FLV31349-1	ST254 V12 ACCBG	254	146
FLV31351-1	VIFOSA M98 160 KN	280	170



Shoes

ACCESSORIES FOR STRAIN CARRIERS

Catalog Reference	Description	Rated Work Capacity		Approx. Weight	
		daN	lb	kg	lb
RE401-1998	Strain Jack Total length 305 mm The tongue type strain jacks are used in coupling to the strain poles as an adjustment tool in insulator string straining. They are coupled through the eye of the strain pole through the head in one of its ends.	4536	10000	1.30	2.87
RV401-0157	Strain Jack Total length 610 mm	4536	10000	1.80	3.97
RV401-0158	Strain Jack Total length 915 mm	4536	10000	2.30	5.07
RH4785-1	Clevis Type Strain Jack Total length 305 mm Clevis type strain jacks are used in connection with the clevis-eye strain poles (RH1949-113 / RC400-0612 and RC400-0613) as an adjustment tool for straining insulator strings. They are coupled through the eye of the strain pole through the head in one of its ends	4536	10000	1.40	3.09
RH4785-2	Clevis Type Strain Jack Total length 457 mm	4536	10000	1.70	3.75
RH4785-3	Clevis Type Strain Jack Total length 610 mm	4536	10000	2.00	4.41
RT400-0025	Clevis Type Strain Jack Total length 915 mm	4536	10000	2.50	5.51
RE401-2066	Large Trunnion Specially designed for coupling the yokes on the strain poles. They are made of bronze alloy and have bearings to make them light during their rotation on the strain jacks	4536	10000	1.40	3.09
RE401-2068	Simple Trunnion	4536	10000	0.83	1.83
FLV17755-1	Trunnion Gauge Made of steel, this gauge is an essential tool for periodically checking the trunnion threads to check for wear on the trunnion threads. When testing, if the trunnion allows its insertion, even partially, a thread wear of more than 0.5 mm will be identified, thus ensuring that it is unfit for use.	-	-	0.37	0.82



RE401-1998



RH4785-1



RE401-2066



RE401-2068



FLV17755-1

ACCESSORIES FOR STRAIN CARRIERS

Catalog Reference	Description	Rated Work Capacity		Approx. Weight	
		daN	lb	kg	lb
FLV10460-1	Safety steel nut for trunnion support The installation of the locknut is recommended for shortly after placing the trunnions on the strain jacks as additional safety during the strain operation, and acts as a support in the trunnions.	-	-	0.11	0.24
RE401-0138	Ø 51 mm adjustable pole clamp Used for coupling the yokes to the strain pole on the hot end, where allows manually or via stick the adjustment and displacement of the pole clamp for better positioning on the Strain Pole's steel pins.	3402	7500	0.70	1.54
RE401-1510	Steel pin For strain pole clevis	-	-	0.30	0.66
R059738	Click safety cotter pin For yoke steel pin locking	-	-	0.05	0.11
RM1948-3	Ratchet wrench for hex-nuts and trunnions of the strain carrier (255 mm) Used for force application when tightening and loosening hex nuts and trunnions in the maintenance of transmission lines. It has system that allows changing the direction of tightening or loosening during application.	-	-	1.05	2.32
FLV16054-1	Prolonged ratchet wrench for hex-nuts and trunnions of the strain carriers (376 mm)	-	-	1.20	2.65



FLV10460-1



RE401-0138



RE401-1510

R059738



RM1948-3



FLV16054-1

HEAVY-DUTY SUSPENSION LINK STICK

It is designed for suspension of \varnothing 25 to 64 mm conductors and can be used with a number of lifting devices at the structure end.

Constructed with a \varnothing 38 mm RITZGLAS® tube, one end is fitted with a cast aluminum alloy main head with rubber coating to prevent damage to the conductor.

At the other end it is fitted with an aluminum alloy head and non-swivel eye.

Catalog Reference	Conductor Heads (\varnothing)	Dimensions		Rated Work Capacity		Approx. Weight	
		\varnothing (mm)	Insulating Length (m)	daN	lb	kg	lb
RH4719-84	3/4" to 1-3/4"	38	2.00	2948	6500	5.00	11.02
RH4719-96			2.31			5.30	11.68
RH4719-114			2.61			5.70	12.55
RH4720-84	1" to 2-1/2"	38	2.00	2948	6500	5.20	11.45
RH4720-96			2.31			5.50	12.10
RH4720-114			2.61			5.90	13.00

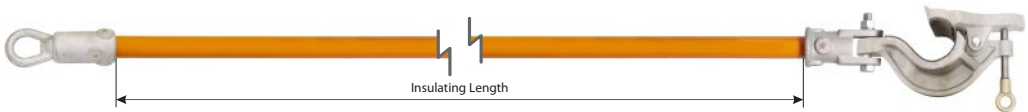

G

ADJUSTABLE HOOK ASSEMBLY

This tool can be used with strain poles RC401-2144 to RC401-2149 and is a simple and fast method of lightening the mechanical load on a suspension string.

It has a circular shape with a movable jaw that is adjusted to the conductor through the eye bolt, which allows a \varnothing 28 to 64 mm (RM4724-1) and \varnothing 14 to 36 mm (FLV16193-1) coupling approximately.

This movable jaw is self-aligning with the conductor as it has a 45° left or right vertical variation.

The hook is adjusted to the steel pole pins every 152 mm.

Catalog Reference	Description	Approx. Weight	
		kg	lb
RM4724-1	Adjustable Hook Assembly (\varnothing 28 to 64 mm)	2.60	5.73
FLV16193-1	Adjustable Hook Assembly (\varnothing 14 to 36 mm)	2.55	5.62

Rated Work Capacity: 1688 daN (3720 lb)



RM4724-1

SUSPENSION POLE WITH ADJUSTABLE HOOK

The position of the conductor hook can be adjusted along the pole according to the length of the insulator string. Tightening the nuts on each side of the adjustable hook clamp ensures their secure connection to the pole.

The hook has wide jaws with rounded corners to prevent crushing or cuts in the conductor.

The swivel eye rotates freely and enables the use of hoists, ropes, or screws. The strain hook and base terminal are made of sturdy, heat-treated aluminum alloy.

Catalog Reference	\varnothing (mm)	Total Length (m)	Insulating Length (m)	Rated Work Capacity		Approx. Weight	
				daN	lb	kg	lb
RH4710-4	64	2.00	1.55	1134	2500	6.50	14.33

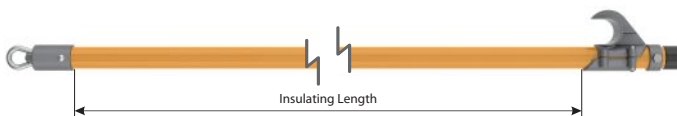

YOKE



They are tools for coupling strain poles to yoke plates, extension links or other support in structures to relieve the mechanical stress of a single or multiple insulator string at anchor or suspension in order to replace damaged insulators.

The yokes are made of heat treated cast aluminum alloy or rolled aluminum plate.

NOTA

Yokes and their components are designed to fit various structure configurations. Where models available in this catalog do not meet a specific structure type, tower arm or support bracket and string arrangement drawings must be submitted for evaluation by our engineering department to design the correct yoke and its components.

Two-pole strain carrier Yokes

For better user information, in some applications, there are matches between the two versions of cast aluminum and rolled aluminum yokes as follows:

RC401-1720

Hot-side double yoke

Double pole strain carrier yoke to suspension or tension double and multiple insulator strings. It is included socket for 7/8" x 1 1/2' extension (RC401-1894). Manufactured in high-strength laminated aluminum plate.

Rated Work Capacity: 6804 daN (15000 lb)

Approx. Weight: 12.90 kg (28.44 lb)

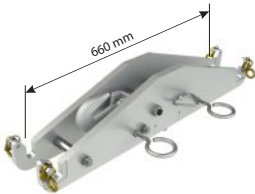

RC401-1720

RM2946-1

Hot-side double yoke or Cold-end

Designed to fit various types of ball clevis and it is used on cold and hot end of the insulator strings. It includes Sockets (RM2945-1, RM2945-3 e RM2945-9). Manufactured in cast aluminum alloy .

Rated Work Capacity: socket 6804 daN (15000 lb)

hook 4000 kg (8818 lb)

Approx. Weight: 9.00 kg (19.85 lb)



RM2946-1

RC401-1720 (rolled) is equivalent to RM2946-1(cast)

RC401-1721

Double yoke with string, cold-end

Double pole strain carrier yoke to suspension or tension double and multiple insulator strings, cold end. Designed to fit various types of yoke plates, and can also be attached to the structure through a chain (RM1942). Manufactured in high-strength laminated aluminum plate.

Rated Work Capacity: 6804 daN (15000 lb)

Approx. Weight: 7.50 kg (16.53 lb)



RM2946-12

Double yoke with string, cold-end

Designed to relieve the mechanical straining from insulator strings, during insulator replacement be attached through a chain (RM1942). Manufactured in cast aluminum alloy.

Rated Work Capacity: 6804 daN (15000 lb)

Approx. Weight: 9.70 kg (21.38 lb)

RC401-1721 (rolled) is equivalent to RM2946-12 (cast)

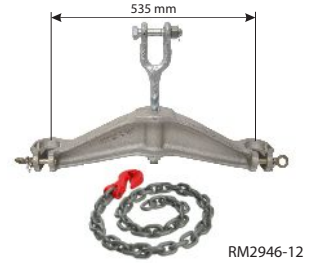

RC401-0095

Two-pole strain carrier yoke

Used for traction of anchor chains during maintenance interventions in transmission line networks. It has a pre-arrangement for fitting adjustable strain poles of Ø51 mm glove at their ends, in addition to glove lock devices made of cast bronze. It does not require the use of wire grips, as it has its own locking system for this function.

It has a quick-fit device that allows remote insertion and closing of the conductor in the shoes. It has lifting and handling eyelets during installation and maintenance.

Manufactured in laminated aluminum alloy.

Rated Work Capacity: 4990 daN (11000 lb)

Approx. Weight: 9.70 kg (21.38 lb)

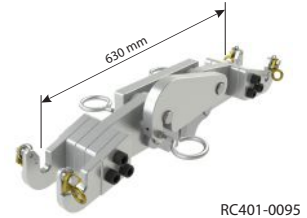

Accompanies 4 sets of shoes with different gauges to fit the tensioning clamps or the conductor of the anchor chains.

- 24 AH for conductors 477 to 556.5 kcmil ACSR Ø 21.7 to 23.4 mm
- 30 AH for conductors 715 to 954 kcmil ACSR Ø 27.4 to 29.6 mm
- 36 AH for conductors 1192.5 to 1351.5 kcmil ACSR Ø 34 to 36.2 mm
- Ø 19.0 to 25.4 mm (3/4" to 1").

RT401-0935

Double yoke, hot end for string "I" suspension (Crate Type)

tool for attachment of 2 sectional strain pole (clevis-clevis) with triple or quadruple bundle yoke plates, side energized, in order to relieve the mechanical load on single or multiple insulator strings, on suspension, for damaged insulator replacement. with high strength laminated aluminum sheets.

Rated Work Capacity: 6804 daN (15000 lb)

Approx. Weight: 17.70 kg (39.02 lb)

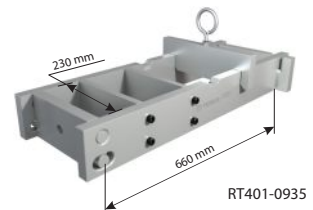

Single Pole Strain Carrier Yokes

They are used with the adjustable strain pole (series RC401-2144 through RC401-2149) to release the mechanical strain during insulator replacement work.

They are designed to adapt to a number of yoke plates in can be used on either the energized or de-energized side of the insulator string.



RC401-1717

RC401-1717

Rectangular-shape yoke plate (maximum thickness: 19 mm | 3/4"), manufactured in high-strength laminated aluminum plate.

Rated Work Capacity: 6804 daN (15000 lb)

Approx. Weight: 13.3 kg (29.32 lb)



RM1947-1

RM1947-1

Rectangular-shape yoke plate (maximum thickness: 19 mm | 3/4"), manufactured in cast aluminum alloy.

Rated Work Capacity: 5443 daN (12000 lb)

Approx. Weight: 14 kg (30.86 lb)

RC401-1717 can replace RM1947-1



RC401-1718

RC401-1718

Triangular-shape yoke plate (maximum thickness: 25,4 mm | 1"), manufactured in high-strength laminated aluminum plate.

Rated Work Capacity: 6804 daN (15000 lb)

Rated Work Capacity: 8.9 kg (19.62 lb)



RC401-0003

RC401-0003

Triangular-shape yoke plate (maximum thickness: 25,4 mm | 1"), manufactured in cast aluminum alloy.

Rated Work Capacity: 3402 daN (7500 lb)

Approx. Weight: 5.20 kg (11.46 lb)

RC401-1718 can replace RC401-0003



RC401-1719

RC401-1719

Triangular-shape yoke plate (maximum thickness: 19 mm | 3/4"), manufactured in high-strength laminated aluminum plate.

Rated Work Capacity: 6804 daN (15000 lb)

Approx. Weight: 9.4 kg (20.72 lb)



RC401-0155

RC401-0155

Triangular-shape yoke plate (maximum thickness: 19 mm | 3/4"), manufactured in cast aluminum alloy.

Rated Work Capacity: 2268 daN (5000 lb)

Approx. Weight: 3.80 kg (8.38 lb)

RC401-1719 can replace RC401-0155



RT401-0573

RT401-0573

Double plate triangular rocker arm hot end yoke, applied in suspension insulators chain, manufactured in laminated aluminum alloy.

Rated Work Capacity: 4990 daN (11000 lb)

Approx. Weight: 4.80 kg (10.58 lb)

Structure Yokes

FLV4783-22

Steel structure yoke

Designed and manufactured in accordance with the IEC61236 standard. It is a practical and extremely versatile tool for the replacement of insulator strings. It simply and quickly fits onto the structure and supports strain poles in order to relieve the mechanical stress of a suspended insulator string in conjunction with hot-end strain poles and yokes.

It allows a 74 to 181 mm adjustment between the support brackets and measures 550 mm from center to center of the swivel brackets for the strain poles.

Rated Work Capacity: 6804 daN (15000 lb)

Approx. Weight: 20,98 kg (46,25 lb)



FLV4783-22

FLV400-0219

Tower yoke

Designed and manufactured in accordance with the IEC61236 standard. It is generally used in "H" crossarms, with similar design and applications to the steel structure yoke (RH4783-22). To adapt to the various crossarm sizes, the fixing screws can be adjusted in three positions from center to center (230, 280, and 330 mm) and 230 to 305 mm from the vertical.

Rated Work Capacity: 6804 daN (15000 lb)

Approx. Weight: 13,99 kg (30,84 lb)



FLV400-0219

RC400-0445

Metal crossarm yoke

It is designed for use at the end of the crossarm, coupled through the RT400-0838 support when necessary. It has its rotary couplings and allows the correct alignment of the strain poles in relation to the yoke on the energized side.

Rated Work Capacity: 6804 daN (15000 lb)
when limited to a 45° angle: 4082 daN (9000 lb)

Approx. Weight: 8.30 kg (18.30 lb)



RC400-0445

RT400-0838

Metal crossarm adapter support

It is used in conjunction with the metal crossarm yoke (RC400-0445) when the metal crossarm does not originally have the yoke attachment bracket. Built in aluminum alloy, it is fixed to the metal crossarm through the chain stretcher.

Rated Work Capacity: 6804 daN (15000 lb)

Approx. Weight: 5.30 kg (11.68 lb)



RT400-0838

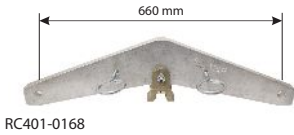

RC401-0168

RC401-0168

Living double side yoke for single "V" suspension string
Attachable to the yoke plate through the sticks with adjustable pole clamp or strain pole clevis-eye. It has a bronze adapter to fit the yoke plate. Used on the energized side. Made of extra strong rolled aluminum plate.

Rated Work Capacity: 6804 daN (15000 lb)

Approx. Weight: 6.50 kg (14.33 lb)



RT401-0689

RT401-0689

V-side double yoke for "V" suspension string and double anchor
Similar to RC401-0168, however, without the bronze adapter. Usually used on the energized side of double-anchored "V" suspension strings, with reduced coupling spaces.

Rated Work Capacity: 6804 daN (15000 lb)

Approx. Weight: 3.50 kg (7.72 lb)



RH4794

RH4794

Suspension hot yoke with 3 1/2" saddle

It is typically used on the hot-end of single "I" suspension strings on 220 to 345 kV twin-cable transmission lines. Constructed of heat-treated cast aluminum alloy, it has a duplicator saddle (RH4794-1) installed at its base.

Rated Work Capacity: 6804 daN (15000 lb)

Approx. Weight: 7.60 kg (16.76 lb)

NOTA

The RH4794-2 duplicator support saddle model (which is also used in conjunction with the Jugo RH4794) can be purchased separately when required.



RC401-1722

RC401-1722

Living double side yoke for single "V" suspension string
Used in conjunction with strain poles (RC401-2144 to RC401-2149 series), it is normally attached to the hot-end yoke plate of the "V" suspension string. Constructed of rolled aluminum plate.

Rated Work Capacity: 6804 daN (15000 lb)

Approx. Weight: 10.30 kg (22.71 lb)

For certain applications, this yoke can be replaced by model RH4794.



RH4794-1

RH4794-1 (3 1/2")

Duplicator support saddle

They are used in conjunction with the RH4794 yoke for coupling to the insulator string yoke plate with continuous 360° rotation.

They have two sizes (89 and 305 mm) for better fit to the yoke plate and both sizes are made of aluminum alloy.

Rated Work Capacity: 6804 daN (15000 lb)

Approx. Weight: 0.69 kg (1.52 lb) 1.00 kg (2.20 lb)



RH4794-2

RH4794-2 (12")

STATIC GROUND

It is designed to eliminate the nuisance of the electrostatic charge during coupling and decoupling of insulator strings when working on energized installations. It also dissipates the static charge through the copper cable (25 mm² size x 2.0 m long) and clamp for connection to structure hardware or conductor cables.

To ground the insulator string on the de-energized side, the grounding clamp must be installed on the structure angle and the pole jaws must be installed on the insulator hardware closest to the structure.

For bare-hand work, the clamp should be installed to the energized hardware and the stick jaws to the second insulator on the energized side.

Constructed with Ø 32 mm RITZGLAS® tube and 0.76 m in total length. Its bronze alloy jaws are designed for Ø 64 to 152 mm insulator hardware.

The clamps for connection to the structure have two installation versions (with T-handle and eyescrew). Both clamps are constructed of bronze alloy, with the clamp body being in aluminum alloy.



Catalog Reference	Description	Insulating Length (m)	Approx. Weight	
			kg	lb
RC600-0000	Static grounding with T-handle connecting clamp	0.43	3.10	6.83
RHG4230-1	Static grounding with connecting eyescrew		3.30	7.27

CRADLE

There are three basic cradle solutions to meet a variety of insulator maintenance and replacement requirements.

All are built with RITZGLAS® tubes for work on 110 to 800 kV anchor or suspension strings.

Single Insulator Cradles

It is generally used in 110 to 230 kV strings, supported by a pair of wire tongs or strain link stick.

Cradle with fittings

It is used in 345 to 500 kV strings and in combination with cradle supports to allow insulators movement.

Cradle with bracket (side opening) for extra high voltage

It is used in anchor strings up to 800 kV to allow single or multiple string removal.

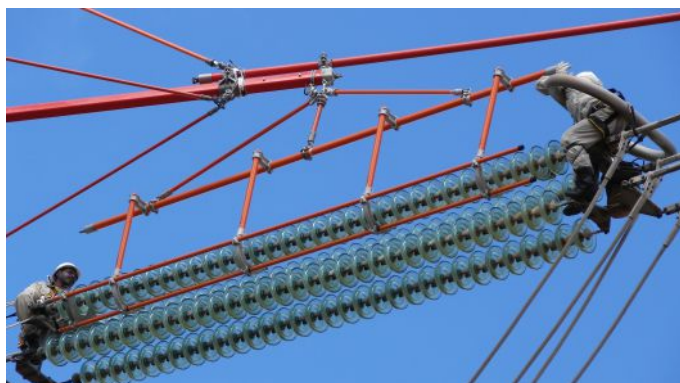

Single Insulator Cradles

It is used to change insulators in the string itself or to lower it to the ground. In anchor strings or angled strings, this cradle is used in conjunction with support rods. As for "I" suspensions, strain poles are used.

Constructed with Ø 38 mm RITZGLAS® tubes, this series of single cradles has two steel pins at their front, which are used to support the insulator string with a pair of wire tongs or strain link stick.

At the rear of the crib there are large eyes and ropes for coupling to the structure as an anchor point. In this way, the insulators can be raised or lowered to a more suitable position for replacement.

When lowering the insulator string is not necessary, the cradles are mounted to the eyes located on the yokes coupled to the strain poles.

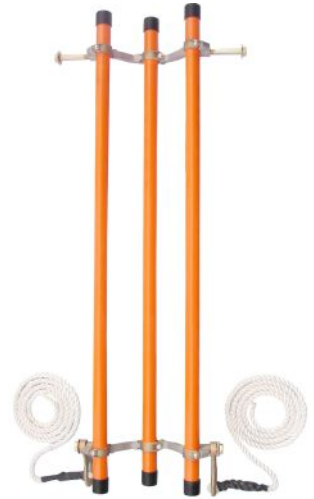

TRANSMISSION INSULATOR CRADLES

Catalog Reference	Maximum Capacity	Insulating Length (m)	Approx. Weight	
			kg	lb
RH1840-4	6 insulators up to Ø 254 mm	1.22	5.80	12.79
RH1840-6	10 insulators up to Ø 254 mm	1.83	7.00	15.43
RH1840-8	14 insulators up to Ø 254 mm	2.44	8.30	18.30
RH1840-10	18 insulators up to Ø 254 mm	3.05	12.20	26.90
RH1840-12	22 insulators up to Ø 254 mm	3.66	14.70	32.41

SPARE PARTS AND COMPONENTS

Catalog Reference	Description	Approx. Weight	
		kg	lb
FLV19067-1	Cradle center spacer	0.80	1.76
FLV17458-1	Metal spacer with side cradle holders	1.00	2.20
FLV17445-1	Metal spacer with side eyes and 2.50 m insulating rope at its cradle ends	1.60	3.53
RH4540	RITZGLAS® tube, Ø 38 mm x 1.22 m, with plastic end fitting	0.90	1.98
RH4540-1	RITZGLAS® tube, Ø 38 mm x 1.83 m, with plastic end fitting	1.30	2.87
RH4540-2	RITZGLAS® tube, Ø 38 mm x 2.44 m, with plastic end fitting	1.70	3.75
RH4540-3	RITZGLAS® tube, Ø 38 mm x 3.05 m, with plastic end fitting	2.10	4.63
RH4540-4	RITZGLAS® tube, Ø 38 mm x 3.65 m, with plastic end fitting	2.50	5.51

Cradle with fittings

It is used to change insulators in strings up to 500 kV. It is also required to lower "V" or anchor insulator strings and to lift "I" suspension insulators.

The deep design of the cradle is a safe way to prevent accidental fall of the insulator string. In addition, it is reinforced by the upper insulator retaining plate, which securely holds it during transport.

The insulator plate has dual use: on one side fits insulators up to Ø 273 mm; and, on the opposite side, it adapts to insulators up to Ø 286 mm.

The cradle can be easily lowered or lifted for insulator change through the forged steel swivel eyes at one end and the other with the aid of the steel handle (R070184) attached to a strain link stick, and it also has an auxiliary hook (R068922).

The steel strap and hook are supplied with the cradle.

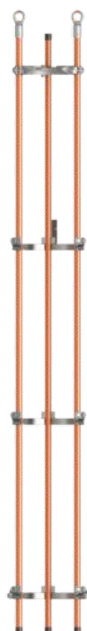

FLV17453-1



FLV17446-1



FLV17447-1



R068922



R070184

EHV THROUGH DESIGN INSULATOR CRADLES

Catalog Reference	Maximum Capacity	Insulating Length (m)	Approx. Weight	
			kg	lb
RC401-0015	25 insulators up to Ø 286 mm	3.40	16.40	36.16
RH1950-9	19 insulators up to Ø 286 mm	2.69	14.90	32.85

SPARE PARTS AND COMPONENTS

Catalog Reference	Description	Approx. Weight	
		kg	lb
FLV17453-1	Cradle center metal spacer	1.60	3.53
FLV17446-1	Aluminum cradle plate	2.60	5.73
FLV17447-1	Metal spacer with side cradle holders	1.60	3.53
R068922	Plastic coated steel hook	0.55	1.21
R070184	Galvanized steel handle	1.10	2.43
FLV18594-4	Ø 38mm RITZGLAS® tube for RC401-0015, with plastic terminal and metal head	3.23	7.12
FLV18593-4	Ø 38mm RITZGLAS® tube for RC401-0015, with plastic terminals	2.60	5.73
FLV18594-3	Ø 38mm RITZGLAS® tube for RH1950-9, with plastic terminal and metal head	2.70	5.95
FLV18593-3	Ø 38mm RITZGLAS® tube for RH1950-9, with plastic terminals	2.07	4.56

Cradle Support

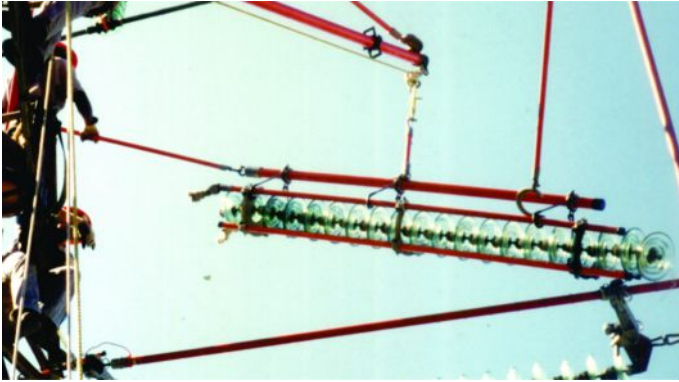

RH1950-90

It is made with Ø 64 mm RITZGLAS® tube and its main structure has a heat-treated aluminum head with forged steel swivel eye and three pairs of hooks, which are coupled to a spiral link pole and act as a support.

Insulating Length: 2.97 m

Rated Work Capacity: 227 daN (500 lb)

Approx. Weight: 13.40 kg (29.54 lb)



Support Cradle

It has been developed for the selective removal of a single insulator string, particularly, in double, triple, or quadruple anchor strings. Using this cradle, it is not necessary to remove the upper strings to extract the lower strings.

Constructed with Ø 64 mm RITZGLAS® tube as its main element, it has three Ø 38 mm pipes.

The tubes has swiveling eyes at its ends.

0.38 m hooks are used in mountings with single or double anchor strings, while with the 0.79 m hook is used to remove quadruple lower anchor strings.

The insulator plate has dual use: on one side fits insulators up to Ø 279 mm; and, on the opposite side, it adapts to insulators up to Ø 324 mm.

In conjunction with the cradle, tie rods are provided for coupling to the boom pole, a plate for retaining the upper insulator, hook arrangements, and metal spacers.

Catalog Reference	Description	Rated Work Capacity		Approx. Weight.	
		daN	lb	kg	lb
RC401-0354	Long insulating cradle of 4.83 m , 4 long support hooks of 0.38 m, 2 metal spacers and 1 plate	454	1000	66.00	136.69
RC401-0355	Long insulating cradle of 4.83 m , 4 long support hooks of 0.79 m, 2 metal spacers and 1 plate			64.00	141.10
RC401-0356	Long insulating cradle of 3.91 m , 4 long support hooks of 0.38 m, 2 metal spacers and 1 plate			58.50	128.97
RC401-0357	Long insulating cradle of 3.91 m , 4 long support hooks of 0.79 m, 2 metal spacers and 1 plate	227	500	60.50	133.38
RC401-0358	Long insulating cradle of 2.69 m , 3 long hooks of 0.38 m and 1 plate			42.60	93.92
RC401-0359	Long insulating cradle of 2.69 m , 3 long hooks of 0.79 m and 1 plate			44.00	97.00

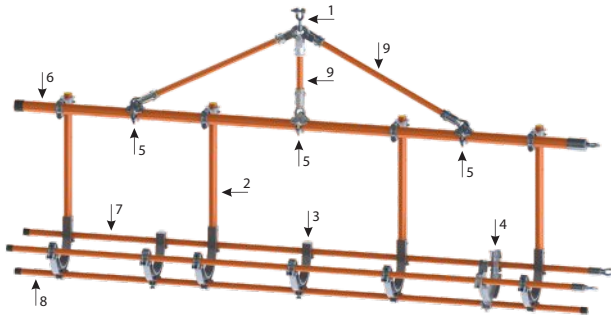

SPARE PARTS AND COMPONENTS

Item	Catalog Reference	Description	Approx. Weight	
			kg	lb
1	FLV01852-1	Cradle tie rod support	1.15	2.54
2	RC401-0361	Cradle support hook with * Ø 51 x 390 mm RITZGLAS®	4.50	9.92
	RC401-0362	Cradle support hook with * Ø 51 x 810 mm RITZGLAS®	5.70	12.55
3	FLV03460-1	Cradle metal spacer	2.60	5.73
4	RC401-0455	Insulator plate	3.15	6.95
5	RE402-0138	Ø 64 mm clamp for rod	0.80	1.75
6	FLV18595-1	Ø 64 X 4830 mm (insulated) RITZGLAS® tube with plastic terminal and eye head	8.80	19.40
	FLV18595-2	Ø 64 X 3890 mm (insulated) RITZGLAS® tube with plastic terminal and eye head	7.45	16.42
	FLV18595-3	Ø 64 X 2675 mm (insulated) RITZGLAS® tube with plastic terminal and eye head	5.40	11.90
7	FLV18594-1	Ø 38 X 4835 mm (insulated) RITZGLAS® tube with plastic terminal and eye head	4.50	9.92
	FLV18594-2	Ø 38 X 3920 mm (insulated) RITZGLAS® tube with plastic terminal and eye head	3.60	7.94
	FLV18594-3	Ø 38 X 2705 mm (insulated) RITZGLAS® tube with plastic terminal and eye head	2.60	5.75
8	FLV18593-1	Ø 38 X 4874 mm RITZGLAS® tube with plastic terminal	3.90	8.60
	FLV18593-2	Ø 38 X 3954 mm RITZGLAS® tube with plastic terminal	2.95	6.50
	FLV18593-3	Ø 38 X 2734 mm RITZGLAS® tube with plastic terminal	2.20	4.85
9	FLV03457-2	Ø 38 x 349 mm (insulated length) RITZGLAS® pole with tie-down head (clevis type) and eye head	2.15	4.74
	FLV03457-3	Ø 38 x 806 mm (insulated length) RITZGLAS® pole with tie-down head (clevis type) and eye head	2.50	5.52
	FLV03457-5	Ø 38 x 1263 mm (insulated length) RITZGLAS® pole with tie-down head (clevis type) and eye head	2.85	6.28
	FLV03457-6	Ø 38 x 1416 mm (insulated length) RITZGLAS® pole with tie-down head (clevis type) and eye head	3.00	6.61



“J” - HOOK ASSEMBLY

It is used as an efficient alternative solution to remove lower insulators in a triple string.

Constructed with RITZGLAS® tube, one end features a freely rotating steel hook for quick and easy string adjustment. To ensure the protection of the insulators, the hook has a plastic coating.

For complete cradle assembly, with the “J” hook assembly, the RC401-0354 to RC401-0359 series cradle main support must be mounted.



RC402-0790

“J”- HOOK ASSEMBLY

Catalog Reference	Ø (mm)	Length (m)	Rated Work Capacity		Approx. Weight	
			daN	lb	kg	lb
RC402-0790	51	0.91	113	250	4.00	8.81

SPARE PARTS AND COMPONENTS

Catalog Reference	Description
FLV03457-2	Small crib tie rod
RC402-0790	“J”- Hook Assembly
FLV18595-1	Ø 64 mm Tube w/ plastic terminal and cradle eye
RE402-0138	Ø 64 mm clamp for rod
FLV03457-6	Cradle tie pole
FLV01852-1	Cradle tie rod support



TROLLEY POLE

It is used to transport the suspension insulator string to the structure.

Constructed with RITZGLAS® tubing and aluminum and steel metal parts, the trolley pole can be installed horizontally under the tower crossarm through the metal structure saddle.

The scoop (RH4723-2), with a socket for Ø 267 to 273 mm insulators, is properly installed on a Ø 64 mm or 76 mm pole, with swivel eye and through the single sheave or double sheave. The latter is used in large strings or heavy insulators, thus forming the trolley pole assembly.

The scoop coupled to the stick is mounted under the first top insulator of the string for removal and horizontal movement for maintenance, and to return it to the original position.



TROLLEY POLE

Catalog Reference	Ø (mm)	Insulating Length (m)	Approx. Weight	
			kg	lb
RH4721-112	64	3.51	9.50	20.94
RC400-0546	76	3.51	13.80	30.42



RH4723-2

COMPONENTS

Catalog Reference	Description	Approx. Weight.	
		kg	lb
RH4723-2	Fork Suspension Tool Attachment for Ø 64 mm pole	6.40	14.11
RH4723-4	Single Trolley Wheel with Ø 64 mm pole clamp	3.60	7.94
RC400-0152	Tandem Trolley Wheel with Ø 64 mm pole clamp	7.30	16.09



RH4723-4

NOTE

SUSPENSION STRING - The fork suspension tool, tandem trolley and trolley pole set is for a rated load of up to 400 daN (880 lb), however the following procedures should be observed in its application:

1. Always use tandem pulleys with 64 mm clamp (RC400-0152).
2. The recommended trolley pole size for this load is Ø 64 mm (RH4721-112).
3. The maximum distance between the trolley pole attachment points on the structure to prevent excessive bending is 2 m.
4. The coupling of the Ø 64 mm Tandem Trolley clamp to the fork suspension tool must be within 500 mm of the scoop center.



RC400-0152

GROUP H



Access our site.



BARE-HAND EQUIPMENT



Conductive Suits	261
Bare-hand Working Chair	263
Inspection Trolley	264
Bare-Hand Stick	265

GROUP H

BARE-HAND EQUIPMENT



CONDUCTIVE SUITS

Conductive suit for work on high voltage transmission lines and substations up to 800kV AC and 600kV DC. It allows the electrician to equalize his/her potential with the electric field of the energized point where the work will be performed.

The conductive suits works based on the Faraday Cage principle, making maintenance work on energized systems safe and comfortable.

Made of high-tech polyamide fabric lined with cotton and silver microfiber and reinforced seams. Its anatomical construction allows the electrician to wear a safety helmet under the hood of the conductive suit without limiting mobility and maintaining the Faraday Cage effect around his/her head.

Available in three sizes: Medium, Large, and Extra Large.

Routine test reports are provided along with the conductive suit. These test data are a parameter of utmost importance for continuous monitoring of conductive suit quality and performance, even after years of use and washing.

The conductive suit meets the requirements of IEC 60895.



H



FLV29842-3 - Face screen for 1000kV AC and 800kV DC suit

CONDUCTIVE SUITS

Catalog Reference	Description	Size	Capacidade
FLV30620-1	Pants, jacket with hood, socks, gloves, and storage bag	Small	800kV Alternating Current / 600kV Direct Current
FLV30620-2	Pants, jacket with hood, socks, gloves, and storage bag	Medium	
FLV30620-3	Pants, jacket with hood, socks, gloves, and storage bag	Large	
FLV30620-4	Pants, jacket with hood, socks, gloves, and storage bag	Extra Large	
FLV30622-1	Conductive socks	Only	
FLV30623-1	Conductive gloves	Only	
FLV29842-4	Pants, jacket with hood, socks, gloves, face screen, and storage bag	Medium	1000kV Alternating Current / 800kV Direct Current
FLV29842-1	Pants, jacket with hood, socks, gloves, face screen, and storage bag	Large	
FLV29842-2	Pants, jacket with hood, socks, gloves, face screen, and storage bag	Extra Large	
FLV29842-3	Face screen mask	Only	

CONDUCTIVE BOOT

Catalog References	Size		
	Brazil	USA	Europe
RC417-0623	37	6	39
RC417-0624	38	7	40
RC417-0624/5	39	7.5	41
RC417-0122/5	40	8.5	42
RC417-0123/5	41	9.5	43
RC417-0124	42	10	44
RC417-0125	43	11	45
RC417-0126	44	12	46
RC417-0126/5	45	12.5	47
RC417-0625/5	46	13.5	48



BARE-HAND WORKING CHAIR

FLV12563-1

Designed for safe, quick, and comfortable transport of the electrician from the ground to the maintenance areas in the structure or close to the power supply.

Its lightweight, sturdy anatomical construction design with RITZGLAS® poles and aluminum fittings allows vertical and horizontal travel operations with absolute precision in approaching the power supply.

It has a device for continuous rotation from the point of connection with the boom, to better position the electrician when transitioning from the chair to the conductor. This device comes with the chair and is optional.

The chair is detachable and has a bag for easy transport, packaging, and storage.

Maximum workload capacity: 120 daN (265 lb)

Approx. Weight: 19.80 kg 43.65 (lb)



INSPECTION TROLLEY

Essential tool for inspection and maintenance of transmission lines.

Through the bare-hand method, the electrician has safe and ergonomical access to the conductors. Its advancing and retreating movements are controlled by a rope from the tower or the ground.

Mostly made of aluminum this equipment is designed for easy handling during transport, installation, and use.



FLV21045-1



FLV21549-1

INSPECTION TROLLEY

Catalog Reference	Description	Work Capacity Rated		Approx. Weight	
		daN	lb	kg	lb
FLV21045-1	for 4 conductors	120	265	38.00	83.75
FLV21549-1	for 3 conductors			55.50	122.36

ACCESSORIES

Item	Quant.	Unit.	Catalog Reference	Description
01	220	m	RM1895-3	Polypropylene rope
02	06	pc	FLV04803-3	Rope insulating stick



BARE-HAND STICK

FLV02544-1

Designed to connect the tap wire of the conductive suit with the energized conductor, in order to establish potential equalization, avoiding discomforts to the electrician during the work.

It is through the bare-hand stick that the first contact of the electrician with the energized conductor is made. Similarly, at the end of the work, it must be disconnected last, thus avoiding electric arcs in the electrician.

Upon returning to ground potential, the stick must first touch the structure to discharge static energy.

Made of a Ø 32 mm RITZGLAS® tube with an insulating length of 340 mm and has a rest strap for the stick and a tap wire for the conductive suit.

Approx. Weight: 1,60 kg (5.53 lb)

CONNECTION TYPE

Detachable clamp.: it is also mounted by twisting the stick, but the electrician can remove the stick, leaving only the mounted clamp. (This clamp has a quick coupling head to hold the clamp eye bolt firmly and securely).

Minimum Opening: 12 mm Maximum Opening: 48 mm



GROUP I



Access our site.



INSTRUMENTS

Phase Tester.....	269
Insulator Tester.....	271
Ritz Tester.....	272
Microammeter.....	273
Hot Line Tester.....	274
Contact Tester.....	275
Contact Tester - CSU.....	276
Contact Tester - Underground System.....	276
Contact Tester - Direct Current.....	277
Multi-Purpose Tester.....	277
Super Tester.....	278
Glove Tester.....	279



INSTRUMENTS



PHASE TESTER

A portable equipment for easy and safe phase sequence determination and comparison, as well as AC, phase-to-phase, or phase-to-ground voltage readings in 1 kV to 80 kV transmission and distribution circuits.

The basic unit is comprised of a 1 kV to 16 Kv direct reading galvanometer and a 6.50 m reel with 6,50 m of 16 kV shielded cable, mounted on two RITZGLAS® sticks, which are high impedance units required for readings on the instrument.

Voltages above 16 kV require extensions (RH1876-4 for 48 kV and RH1876-2 for 80 kV). These extensions are coupled to the threaded end of the instrument stick for indirect reading, that is, x3 full scale for 48 kV and x5 full scale for 80 kV.

A pair of extensions must be used for 48 kV (RH1876-4) and two pairs for 80 kV (RH1876-2). Length of each unit: 630 mm.

The Calibration Device (H1876/B-AFT) is designed to calibrate the phase detector before use, especially after a long inactivity period. It generates a digital signal to the phase detector so that the user can compare the galvanometer reading with the value on the calibration device display.

This Calibration Device must be ordered separately.

Power supply: 9V battery





RH1876-1

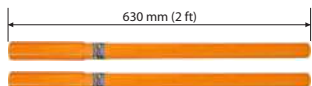

RH1876-4



H1876/B-AFT

PHASE TESTER

Catalog Reference	Description	Aprox. Weight	
		kg	lb
RH1876	Complete phase tester kit for phases up to 16 kV, including detector, case, two universal sticks, bag for universal sticks, and instruction manual	10.90	24.03
RH1876-1	Phase tester and case for 16 kV only	8.35	18.41
RH1876-2	Resistor extension kit for 80 kV Phase Detector	2.84	6.26
RH1876-4	Resistor extension kit for 48 kV Phase Detector	1.42	3.13
H1876/B-AFT	Phase tester calibration device	1.00	2.20



RH1876

ACCESSORY

Catalog Reference	Description	Aprox. weight	
		kg	lb
RH1760-1	Ø 32 mm Universal stick and 1.75 m insulated length	1.30	2.87



INSULATOR TESTER

TILV-16/DT

A portable device designed to quickly locate a faulty isolator in the insulator chain in hot distribution and transmission circuits.

Aprox. Weight: 1.13 kg (2.49 lb)

Its working principle is based on measuring the potential difference in the tested insulator disc. A high impedance galvanometer indicates this potential difference for comparisons with other isolator discs in the same system. Thus, a defective isolator will show a reading considerably lower than the others.

It can be used to evaluate pin insulators, one piece isolators, multipart pin insulators, and disc insulators.

It is made of fiberglass tubing and housing, with quick and multiangular adjustment of contact tips. The insulator tester is designed to test any insulator measurement and to make other adjustments for better viewing.

The instrument has a 3-position switch on its backside to change sensitivity for a better selection of pointer range.



TILV-16/DT

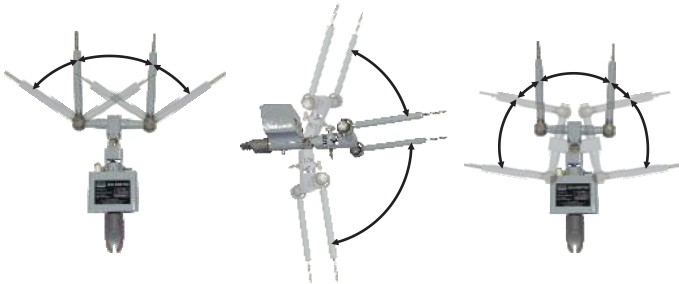

TILV-16/AFT

The calibration device is designed to check the insulator tester before use, especially after a long inactive period.

Aprox. Weight: 1.00 kg (2.20 lb)

It generates a digital signal to the insulator to compare the values shown in the calibration display and the insulator tester galvanometer reading.



TILV-16/AFT

RITZ TESTER

A portable device for periodic electrical testing of hot line insulated poles, hot sticks and poles, hot line ladders and insulated scaffolds that detects the leakage current caused by moisture, cracks, and impurities on or inside the insulated poles.

Operation is easy and simple, and only requires a single operator, through the direct contact of the Ritz Tester with the surface to be tested, indicating a "PASS" or "FAIL" graph, according to the leakage current of the tested element.

This instrument simulates the test specified in the ASTM F-711 standard. A test carried out by the Ritz Tester offers a guarantee that the equipment is ready for use. It can not be used as a reporting test.

There are four versions available:

LS-80 | **LS-81** | **RT-110** | **RT-220**
 (standard sizes) | (reduced sizes)

These models perform electrical tests corresponding to an applied voltage of 100 kV in 30 cm according to the standard. To perform the test, the stick must be supported horizontally on two easels.

LS-80/WD | **LS-81/WD**

These models can be used for electrical tests on wet and dry sticks through a key switch on the front panel of the instrument. In the wet function, an electrical test corresponding to a voltage of 75 kV in 30 cm is reproduced. And the dry function corresponds to a voltage of 100 kV in 30 cm.



LS-80



RT-110

Catalog Reference	Description	Dimensions (mm)	Aprox. weight			
			Instrument		Case	
			kg	lb	kg	lb
LS-80	For 110 V	200 x 365 x 310	5.30	11.68	5.20	11.46
LS-81	For 220 V					
RT-110	Reduced model, 110 V	155 x 250 x 250	3.40	7.50	2.80	6.17
RT-220	Reduced model, 220 V					
LS-80/WD	WET/DRY, for 110 V	200 x 365 x 310	5.30	11.68	5.20	11.46
LS-81/WD	WET/DRY, for 220 V					

MICROAMMETER

A device that measures leakage current of insulated structures in direct contact with the hot line.

It is designed to measure and monitor leakage current in insulating structures such as ladders, scaffolds, man basket insulated arms, among others.

RC402-0288

Analog Micro Ammeter

It measures leakage currents of up to 200 μA .

Aprox. Weight: 1.50 kg (3.30 lb)



RC402-0288

MD800

Digital Micro Ammeter

It measures and monitors leakage currents of up to 800 μA .

Aprox. Weight: 3.12 kg (6.88 lb)

The maximum allowed leakage current value for the structure to be monitored can be set on the MD800 and sound and light will be emitted if the leakage current value is higher than the value set on the device.

Designed to operate on insulating structures that are in contact with transmission lines of up to 500 kV.



MD800

HOT LINE TESTER

Electronic instrument to detect the absence of alternating voltage in distribution lines, substations, and transmission lines, with bare conductors.

Operation Frequency: 60 Hz

It is required due to the high voltage spikes when system power is restored. Thus, the electrician can carry out safety procedures while the system is de-energized.

Developed in accordance with the IEC 61243-1/09 international standard, it includes an operation testing system and standby status.



Medium voltage instrument



High voltage instrument

Catalog Reference	Voltage Ranges	Voltage Class	Instrument Color	Aprox. weight*	
				kg	lb
NHL 10-40	10 kV - 40 kV	Medium	Orange	0,72	1,59
NHL 20-80	20 kV - 80 kV	High-medium	Orange		
NHL 60-240	60 kV - 240 kV	High	Black		

*Weight without packaging

The clamp mounted instrument model can be used in bare conductor networks or compact networks.



NHL 10-40/GR

Catalog Reference	Voltage Ranges	Voltage Class	Instrument Color	Aprox. weight*	
				kg	lb
NHL 10-40/GR	10 kV - 40 kV	Medium	Orange	0,75	1,65

*Weight without packaging

CONTACT TESTER

A contact AC voltage detector instrument, designed for use with a hot stick. The electronic circuit offers a safe and accurate response through light and sound indications.

Operation Frequency: 60 Hz

Tested in accordance with international standard IEC 61243-1/09 and indispensable for compliance with the Safety Regulatory Standard in Electrical Installations and Services NR-10 (Item 10.5.1-C - verification of absence of voltage).

The contact tester offers fast and safe voltage checks in AC installations in:

- Transmission lines;
- Distribution lines;
- Substations;
- Switchgears.

The CT 0.07-1 model has an on/off switch, the others are stand by.



Low and medium voltage instrument



High voltage instrument

Catalog Reference	Voltage Ranges	Voltage Class	Instrument Color	Aprox. Weight*	
				kg	lb
CT 0,07-1**	70V - 1 kV	Low	Brown	0.29	0.63
CT 2-8/SB	2 kV - 8 kV	Low	Orange	0.29	0.63
CT 3,8-36/SB***	3,8 kV - 36 kV	Medium	Orange	0.29	0.63
CT 10-40/SB	10 kV - 40 kV	Medium	Orange	0.29	0.63
CT 20-80/SB	20kV - 80 kV	Medium-high	Orange	0.42	0.92
CT 60-240/SB	60 kV - 240 kV	High	Black	0.42	0.92
CT 180-540/SB	180 kV - 540 kV	High	Black	0.42	0.92

* Weight without packaging.

** Does not cover the IEC 61243-1 standard

*** Does not comply with Item - 4.2.1.2 THRESHOLD VOLTAGE - of the IEC61243-1 standard. It complies with the other requirements of the standard.

CONTACT TESTER - CSU

An instrument used to check live circuits for voltage. It contains sound and light indicator signals. This equipment model signals the presence of voltage only when the equipment electrode is in contact with the hot point to be tested.

Operation Frequency: 60 Hz

Thanks to its universal fitting head, this model can be used for other functions such as disconnecting fuse switches. Its pole is subjected to the tensile test with the same strain as the hot stick.



Catalog Reference	Voltage Ranges	Voltage Class	Instrument color	Aprox. Weight*	
				kg	lb
CT-CSU-3.8-36/SB**	3.8 kV - 36 kV	Medium	Orange	0,65	1,43
CT-CSU-10-40	10 kV - 40 kV				

* Weight without packaging.

** Does not cover the IEC 61243-1 standard

CONTACT TESTER UNDERGROUND SYSTEM

An AC voltage detector designed to detect voltage in elbow and straight connectors in underground networks. Its contact electrode has been designed to cap and uncap these types of connectors for testing.



TECHNICAL CHARACTERISTICS

- Stand-by equipment;
- Light and sound indication of voltage;
- Built-in self-test circuit;
- Elbow contact electrode;
- Universal adapter for hot stick or pole.



Catalog Reference	Voltage Range	Voltage Class	Instrument Color	Aprox. Weight	
				kg	lb
CT-RS/C 2-6	2 - 6 kV	Low	Orange	0.34	0.75
CT-RS/C 3,8-36	3.8 - 36 kV	Medium	Orange	0.34	0.75

CONTACT TESTER DIRECT CURRENT

CT-CC 0.5-5

Voltage detector designed for contact voltage detection. Two-pole equipment where a clamp is grounded and the electrode is used to detect voltage at the desired point.

Aprox. Weight: 1.10 kg (2.43 lb)



TECHNICAL CHARACTERISTICS

- Voltage range: 500 V - 5 kV;
- Equipment with on/off/test switch;
- Light and sound indication of voltage;
- Universal adapter for hot stick or pole;
- Built-in self-test circuit with cable test circuit.



MULTI-PURPOSE TESTER

Designed to safely for contact and no-contact voltage detection in alternating current electrical installations with unshielded conductors. It is ideal for distribution lines, substations, and switchgears.

Catalog Reference	Voltage Range	Model	Aprox. Weight	
			kg	lb
DMU-15	110 V - 600 V contact 601 V - 15 kV non-contact	With on/off switch	0.30	0.66
DMU-25	110 V - 25 kV	With on/off switch		
DMU-36/SB	220 V - 36 kV	Stand-by		



DMU (with switch)



DMU (stand-by)

SUPER TESTER

A non-contact voltage detector designed for use with a hot stick or pole. The electronic circuit provides accurate and reliable indications through visual and audible signals.

This device can safely detect voltage from 1 kV in alternating current installations such as transmission and distribution lines, substations, switchgears, etc., with unshielded conductors.

It is indispensable in maintenance services on electrical installations so the electrician can be sure that the work place is de-energized, thus enabling the installation of the temporary grounding set, which will ensure the necessary safety to perform the tasks.



Catalog Reference	Description	Approx. Weight	
		kg	lb
H1990/ST-138	Non-contact high voltage one-pole detector in the range of 1 to 138 kV	1.00	2.20
H1990/ST-800	Non-contact high voltage one-pole detector in the range of 1 to 800 kV		



TECHNICAL CHARACTERISTICS

- Suitable for indoor and outdoor use;
- Built-in operation test;
- Simultaneous sound and light dual signal;
- Encapsulated electronic circuit immune to temperature differences from - 10 °C to 60 °C;
- LED indicator for perfect device operation and battery charge condition
- Packaging: synthetic material case;
- Universal adapter for hot stick;
- Dimensions: 180 x 100 x 90 mm;
- Operation: By proximity to the electromagnetic field;
- Alarm Signal: Light - through 4 front LEDs;
Sound - through piezoelectric transducer;
- Work Frequency: 50 / 60 Hz;
- Power supply: 9V battery - average duration for uninterrupted work 15h.

GLOVE TESTER

FLV11404-1

Designed to perform visual inspection of rubber insulating gloves of all voltage classes, allowing immediate detection of any damage that may compromise its insulating characteristics, however small it may be, anywhere on its surface. It can be used in the workplace or test laboratories. It can be operated manually by pump or connected to a compressed air source.

Aprox. Weight: 7.75 kg (17.09 lb)

Rubber insulating gloves deserve special care, including a periodic visual inspection before use, in addition to periodic electrical tests, as this equipment is subject to cracks, punctures and cuts. These are damages that seriously compromise their insulating characteristics and put the user at risk.



GROUP J



Access our site.



TEMPORARY JUMPERS



Insulated Cable	283	Temporary Jumper Protection Devices.....	291
Insulated Clamp.....	284	Temporary Fuse Switch.....	291
Copper Ferrule for Cables.....	284	Insulated Hanger.....	292
Bypass Clamp	285	Temporary Switching Tool Device.....	292
Insulated Handle for Clamp.....	285	Temporary Crossarm Big Jumper	293
Temporary Jumper Sets	286	Temporary Crossarm Big Jumper Circular or Double-T Pole	294
Transformer Bushing Temporary Jumper	288	Temporary Bypass For Fuse Switch.....	294
Jumper Supports.....	290	Mobile Switch-Off.....	295
Transformer Bushing Clamp	290		

TEMPORARY JUMPERS



INSULATED CABLE

Intended to be used in assembling jumpers for temporary power shunts in AC networks.

Cable (type II) manufactured with flexible copper conductor covered with insulating protection of thermosetting compound based on ethylene-propylene (EPR) and covering in thermoset compound based on Polychloroprene, with resistance to abrasion, oil, heat, moisture and ozone effects.

For easy identification and classification, voltage and size (in AWG) are recorded over the entire length of the cable at regular spacings.



Catalog Reference	Rated Voltage (kV)	Cross Section (mm ²)	Cable Size (AWG)	Copper Conductor Rated Ø (mm)	Maximum Current Capacity (A)	Approx. Weight /m	
						kg	lb
R3641	15	35	2	8	200	0.77	1.70
R3861	15	50	1/0	10	250	1.40	3.09
R3863	15	70	2/0	12	300	1.70	3.75
R3866	15	95	4/0	15	400	2.35	5.18
FLV30463-1	25	50	1/0	10	250	1.50	3.31
FLV30463-2	25	70	2/0	12	300	1.65	3.64
FLV30463-3	25	95	4/0	15	400	2.20	4.85
FLV30182-1	35	50	1/0	10	250	1.70	3.75
FLV30182-2	35	70	2/0	12	300	2.16	4.76
FLV30182-3	35	95	4/0	15	400	2.90	6.39

INSULATED CLAMP

It is suitable for rubber glove interventions in energized installations up to 36 kV. It is connected to the conductor by manual twisting, to close and open the jaw, which will mount to the conductor firmly and safely.

It is connected to the jumper cable via a copper ferrule, which must be purchased separately.

Tool belonging to the group of temporary jumpers. The clamp body is constructed with orange thermoplastic protection and bronze alloy jaws.

Nominal current capacity: 400 A.

Catalog Reference	Description	Voltage Class (kV)	Clamp Connection Capability		Approx. Weight	
			Minimum	Maximum	kg	lb
RT601-0039	Insulated clamp in orange polyethylene	25	# 6 Copper Ø 4 mm	477 MCM CAA Ø 22 mm	1.25	2.76
FLV30339-2	Insulated clamp in orange polyethylene	36	# 6 Copper Ø 4 mm	954 ACSR Ø 31 mm	1.50	3.30
FLV30339-1	Insulated clamp in transparent polycarbonate	36	# 6 Copper Ø 4 mm	954 ACSR Ø 31 mm	1.50	3.30

COPPER FERRULE FOR CABLES

Plain Threaded Terminal

It is designed for cable connections to protected clamps (RG4765) and bypass clamps (RC600-1743).

One of its ends has a 5/8" thread, with nut and lock washer, the other has an internal cavity to mount and then press the jumper cable.

Catalog Reference	Application	Burdny Matrix No. or equivalent	Compression Number	Approx. Weight	
				kg	lb
RC600-2598	2 AWG cable	U 165	2	0.12	0.26
RC600-2599	1/0 AWG cable			0.12	0.26
RC600-2600	2/0 AWG cable	0.14		0.31	
RC600-2601	4/0 AWG cable	U 166		0.15	0.33



BYPASS CLAMP

It is made of aluminum alloy and bronze alloy eyescrew suitable for hot stick work with the aid of a RITZGLAS® hot stick.

Catalog Reference	Clamp Connection Capability		Approx. Weight	
	Minimum	Maximum	kg	lb
RG3622-1	#6 Copper Ø 4 mm	900 MCM CAA Ø 29 mm	0.70	1.54
RG3622-2			0.76	1.68
RC600-1743		1590 MCM CAA Ø 38 mm	0.72	1.59



RG3622-1



RG3622-2



RC600-1743

INSULATED HANDLE FOR CLAMP

FLV30535-1

Insulated Handle for Clamp for maximum voltage 15 kV

Tool specially designed to apply torque to the clamp eye bolt. The high dielectric strength of the material offers safety and practicality when handling the electrician. It has a polyamide body with an opening for fitting the eye screw.

Approx. Weight: 0.50 kg (1.10 lb)



FLV30535-1

TEMPORARY JUMPER SETS

Temporary bypass is a common practice for interventions on energized installations. It can be performed from a distance, with the aid of maneuvering rods or rubber glove methods.

All temporary jumpers use two copper ferrules, one at each end of the cable to connect the clamps.

15 kV TEMPORARY JUMPER RUBBER GLOVE INSTALLATION WITH CLAMP RT601-0039



Catalog Reference	Cable Size (AWG) Type II	Clamp Connection Range		Overall Length (m)	Rated Current Cap. (A)	Approx. Weight	
		Minimum	Maximum			kg	lb
RC601-0171	2	#6 Copper Ø 4 mm	477 MCM CAA Ø 22 mm	3.70	200	5.20	11.46
RC601-0172	1/0					6.70	14.77
RC601-0173	2/0					7.80	17.20
RC601-0174	4/0					10.20	22.49

35 kV TEMPORARY JUMPER RUBBER GLOVE INSTALLATION WITH CLAMP FLV30339-2



Catalog Reference	Cable Size (AWG) Type II	Clamp Connection Range		Overall Length (m)	Rated Current Cap. (A)	Approx. Weight	
		Minimum	Maximum			kg	lb
FLV30765-2	1/0	#6 Copper Ø 4 mm	954 ACSR Ø 31mm	3.70	250	6.70	14.77
FLV30765-3	2/0					7.80	17.20
FLV30765-4	4/0					10.20	22.49

35 kV TEMPORARY JUMPER RUBBER GLOVE INSTALLATION WITH CLAMP FLV30339-1



Catalog Reference	Cable Size (AWG) Type II	Clamp Connection Range		Overall Length (m)	Rated Current Cap. (A)	Approx. Weight	
		Minimum	Maximum			kg	lb
FLV30994-2	1/0	#6 Copper Ø 4 mm	954 ACSR Ø 31mm	3.70	250	6.70	14.77
FLV30994-3	2/0					7.80	17.20
FLV30994-4	4/0					10.20	22.49

15 kV TEMPORARY JUMPER
HOT STICK INSTALLATION WITH CLAMP RG3622-1

Catalog Reference	Cable Size (AWG) Type II	Clamp Connection Range		Overall Length (m)	Rated Current Cap. (A)	Approx. Weight	
		Minimum	Maximum			kg	lb
FLV17443-1	2	#6 Copper Ø 4 mm	900 MCM CAA Ø 29 mm	3.70	200	4.80	10.58
FLV17443-5				4.60		5.50	12.13
FLV17443-2	1/0			3.70	260	7.10	15.65
FLV17443-6				4.60		8.40	18.52
FLV17443-3	2/0			3.70	300	8.30	18.30
FLV17443-7				4.60		9.80	21.61
FLV17443-4	4/0			3.70	400	10.70	23.59
FLV17443-8				4.60		12.80	28.22



25 kV TEMPORARY JUMPER
HOT STICK INSTALLATION WITH CLAMP RG3622-2

Catalog Reference	Cable Size (AWG) Type II	Clamp Connection Range		Overall Length (m)	Rated Current Cap. (A)	Approx. Weight	
		Minimum	Maximum			kg	lb
FLV30752-1	1/0	#6 Copper Ø 4 mm	900 MCM CAA Ø 29 mm	3.70	250	7.23	15.94
FLV30752-2				4.60		8.58	18.92
FLV30752-3	2/0			3.70	300	8.79	18.17
FLV30752-4				4.60		9.27	20.44



35 kV TEMPORARY JUMPER
HOT STICK INSTALLATION WITH CLAMP RG3622-2

Catalog Reference	Cable Size (AWG) Type II	Clamp Connection Range		Overall Length (m)	Rated Current Cap. (A)	Approx. Weight	
		Minimum	Maximum			kg	lb
FLV30752-5	1/0	#6 Copper Ø 4 mm	900 MCM CAA Ø 29 mm	3.70	250	8.01	17.66
FLV30752-6				4.60		9.54	21.03
FLV30752-7	2/0			3.70	300	9.71	21.41
FLV30752-8				4.60		11.65	25.68
FLV30752-9				4/0		3.70	400



15 kV TEMPORARY JUMPER HOT STICK INSTALLATION WITH CLAMP RC600-1743



Catalog Reference	Cable Size (AWG) Type II	Clamp Connection Range		Overall Length (m)	Rated Current Cap. (A)	Approx. Weight	
		Minimum	Maximum			kg	lb
RT601-0281	2	#6 Copper Ø 4 mm	1590 MCM CAA Ø 38 mm	3.70	200	4.50	9.92
RT601-0282				4.60		5.20	11.46
RT601-0283	1/0			3.70	260	6.90	15.21
RT601-0284				4.60		8.10	17.86
RT601-0285	2/0			3.70	300	8.00	17.64
RT601-0286				4.60		9.50	20.94
RT601-0287	4/0			3.70	400	10.40	22.93
RT601-0288				4.60		12.60	27.78



TRANSFORMER BUSHING TEMPORARY JUMPER

Using this tool is a standard practice in interventions in energized medium voltage installations for replacement and/or repair operations of components installed between the transformer bushings and the network, both from a distance and in rubber glove with the hot line.

Arranged in two mounting versions (both built with 14.6 kV - 2 AWG size shielded cable).

Rated Current Capacity: 100A



FLV17448-1

Item	Quant.	Unit.	Catalog Reference	Description
01	01	pc	FLV11179-2	Transformer bushing clamp
02	01	pc	RG3622-1	Twisting clamp
03	3,5	m	R3641	15 kV shielded cable - 2 AWG size
04	01	pc	FLV05784-1	Jumper protection device
05	1	pc	RS1600-7	Insulated hanger

Approx. Weight: 5.80 kg (12.79 lb)

**FLV17449-1**

Item	Quant.	Unit.	Catalog Reference	Description
01	01	pc	FLV11179-2	Transformer bushing clamp
02	01	pc	RG3622-1	Twisting clamp
03	3,5	m	R3641	15 kV shielded cable - 2 AWG size
04	01	pc	RC600-1895	Fuse switch

Approx. Weight: 8,10 kg (17,86 lb)



JUMPER SUPPORTS

RC601-0013

Pole-mounted with a chain strap, it is designed to support jumpers cables.

Constructed with $\varnothing 64 \times 1,22$ m RITZGLAS® tube, composed of four swivel collar clamps (each collar has a cable clamping capacity between 19 and 38 mm in diameter), provided with an internal device to prevent the jumper from slipping, avoiding its contact with the ground.

Rated working capacity on each collar: 34 daN (75 lb)

Approx. Weight: 11.30 kg (24.91 lb)



FLV11179-1

TRANSFORMER BUSHING CLAMP

It is designed to be installed directly on the transformer bushing in energized installation interventions.

Available in four models, which are unique regarding their jaw clamping devices and one is designed for angled operation.



FLV11179-4

FLV11179-1

FLV11179-4 (outbound cable outlet)

It has an eyescrow and is clamped using a hot stick.

Approx. Weight: 0.80 kg (1.76 lb)



FLV11179-3

FLV11179-3

FLV11179-5 (outbound cable outlet)

Its jaws are driven by the "T" type screw and mounted by rubber glove.

Approx. Weight: 0.80 kg (1.76 lb)



FLV11179-5

FLV11179-2

FLV11179-6

It has a $\varnothing 25 \times 0,21$ m insulated grip, with a rubber drip pan. It is installed by rubber glove.

Approx. Weight: 0.80 kg (1.76 lb)



FLV11179-2



FLV11179-6

TEMPORARY JUMPER PROTECTION DEVICES

FLV05784-1

It consists of a fuse holder cartridge with aluminum coupling terminals used as a temporary transformer bushing jumper component.

The clamp (RG3622-1) is mounted to the tool head from one of its hands and to the 2 AWG jumper cable from the other.

Rated Current Capacity: 100A

Approx. Weigh: 11.30 kg (24.91 lb)

NOTE

The fuse link is not included and must be selected and installed by the user. High performance fuse links are recommended.



TEMPORARY FUSE SWITCH

It is designed to maintain protection during interventions on conventional distribution network fuse switches, as a temporary transformer bushing jumper component.

This switch is mounted and removed with a hot stick.

Its lower end bronze pin is for temporary jumper connection. The Ø 32 mm RITZGLAS® pipe with two rubber skirts ensures insulation.

Catalog Reference	Description	Voltage Class	Approx. weight	
			kg	lb
RC600-1895	Standard	up to 27 kV	4.10	9.04
RC600-1944	Pivot lever		4.40	9.70

NOTES

- Fuse links are not supplied with the fuse switch and must be purchased by third parties with a maximum capacity of 100 A.
- Opening this switch under a load requires the use of a loadbuster device
- The temporary pivot lever fuse switch allows is designed to close on the opposite side of the fuse holder using a hot stick.



RC600-1895



RC600-1944



INSULATED HANGER

RS1600-7

Used for installation of the temporary jumper on energized lines up to 34.5kV phase-phase. The insulating support holds the ends of the jumper without it energizes, allowing handling and installing the other end safely. It is fixed to the conductor by a twisting clamp with eyescrew using the hot stick.

Stick made of fiberglass insulated tube impregnated with epoxy resin, bronze alloy heads and RG3403 clamp.

Nominal Load Capacity: 50 daN
Approx. Weight: 1.00 kg (2.20 lb)

TEMPORARY SWITCHING TOOL DEVICE



A device designed for the safe and economical temporary sectionalizing of circuits in distribution networks up to 24 and 36 kV, by de-energizing specific sections for maintenance.

The operation consists of mounting this tool on 1/0 to 336.4 MCM conductors (Ø 10 to 18 mm) with hot line working procedures at predetermined points. This will allow releasing de-energized sections for a short period for maintenance.

Installation should always be performed close to the structure and with hot line procedures.

For increased operational safety, the three temporary switching tool device must not be mounted in alignment with the adjacent tool.

This tool has the same characteristics as the conventional disconnect switch, with insulated components, so it is suitable for this type of intervention.

It can be opened under a load, using a loadbuster device.



Catalog Reference	Description	Approx. Weight	
		kg	lb
FLV13917-1	Temporary switching tool device with voltage class up to 24 kV	5.20	11.46
FLV30047-1	Temporary switching tool device with voltage class up to 36 kV	5.50	12.10

TEMPORARY CROSSARM BIG JUMPER

The big jumper temporary crossarm is designed for emergency interventions or power supply to temporary consumers for a specified period.

Constructed with Ø 64 mm x 1.30 m long RITZGLAS® tube, it has three fuse switches with a maximum current capacity of 100 A, a pole mounting system with two steel screws and a wing nut. It can be used on installations up to 27 kV.



Catalog Reference	Description	Approx. Weight	
		kg	lb
FLV13033-1	A big jumper temporary crossarm provided with three temporary fuse switches	22.60	49.80



FLV13033-1

NOTE

The fuse link is not included and must be selected and installed by the user. High performance fuse links are recommended.

ACCESSORY

Catalog Reference	Description	Approx. Weight	
		kg	lb
FLV13045-1	Temporary fuse switch for big jumpers up to 27 kV	4.50	9.90



FLV13045-1

TEMPORARY CROSSARM BIG JUMPER CIRCULAR OR DOUBLE-T POLE

It is designed for emergency interventions or power supply to temporary consumers for a specified period. It also has a mounting system for circular or square poles.

FLV29780-1



FLV29780-1

It has three fuse switches with a maximum current capacity of 100 A. It can also be used in installations up to 27 kV.

Approx. Weight: 26.40 kg (58.20 lb)

FLV30049-1



FLV30049-1

It has three disconnect switches, with a maximum current capacity of 400 A and three insulated jumpers, with 95mm² size, three-meter cable and a maximum capacity of 400 A. It can also be used in installations up to 27 kV.

Approx. Weight: 45.00 kg (99.20 lb)

TEMPORARY BYPASS FOR FUSE SWITCH

A device designed for temporary release of fuse switch cartridges. It creates an alternate current path for fuse link replacement on various switch types up to 27kV.

Installed with a hot stick, its end eyescrew provides a significant number of operating possibilities.

Available in spring-loaded or bolt drive opening and closing models.

FLV12409-1



FLV29374



Catalog Reference	Opening and Closing System	Voltage Class (kV)	Rated Current (A)	Opening Capacity (mm)		Approx. Weight	
				Min.	Max.	kg	lb
FLV12409-1	Clamp bolt	25		280	442	1.47	3.24
FLV29374-1	Spring-loaded	15	100	276	366	0.78	1.72
FLV29374-2	Spring-loaded	27		337	460	0.85	1.90

MOBILE SWITCH-OFF

Equipment with an insulated structure and remote control that enables the connection and disconnection of PT's (Potential transformers) and SA's (Surge Arresters) in buses and energized transmission lines terminals from 69 to 500kV substations, which associated with live line techniques, allows maintenance or replacement of equipment without having to switch circuits.

Designed for easy field assembly by hot line crews while maintaining the routine use of insulated scaffolding and safety distances.

To use the Mobile Switch is necessary an insulated Scaffold that must be purchased separately.



MAIN ADVANTAGES

- Increased power availability from utilities.
- Increased operational flexibility for maintenance teams.
- Reduced labor costs.
- Reduced equipment downtime in the electrical system.

BASIC CHARACTERISTICS

- Nominal operating voltage: 69 to 500 kV
- Contacts rated current: 1200 A
- Max. atmospheric impulse voltage: 1050 kV
- Time of opening and closing: 1.5 s
- Working voltage: 220 V
- Typical opening and closing: 1A
- Remote opening and closing
- Lever for emergency manual operation

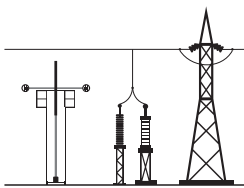

1 Scaffolding is mounted with an open disconnect switch

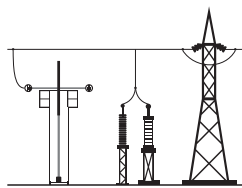

2 The first jumper is connected to LV

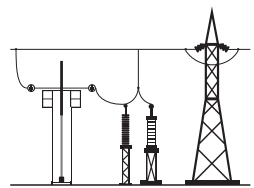

3 The second jumper is connected to LV

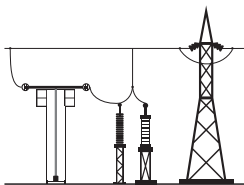

4 Disconnect switch is closed

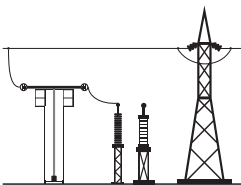

5 Jumpers are disconnected from LV equipment

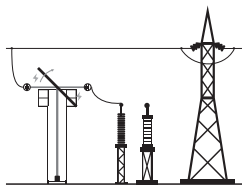

6 Disconnect switch is opened

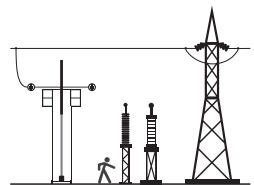

7 The second jumper is removed and maintenance is performed.



FLV18169-1 | FLV18169-2



FLV17173-1 | FLV25726-1



FLV18158-1 | FLV18158-3



FLV18158-2 | FLV18158-4



FLV18158-5 | FLV18158-6



FLV17172-1



FLV18170-1



FLV18161-1

MOBILE SWITCH-OFF

Catalog Reference	Description
FLV28201-1	Mobile switch-off for intervention on energized lines with voltages from 69 to 230 kV
FLV18171-1	Mobile switch-off for intervention on energized lines with voltages from 230 to 500 kV

COMPONENTS

FLV28201-1		FLV18171-1		Unit.	Catalog Reference	Description
Height (m)	Height (m)	Height (m)	Height (m)			
4	6	6	11			
Qty.	Qty.	Qty.	Qty.			
1	1	1	1	pç	FLV18169-1	Lifting gins
1	1	1	1	pç	FLV18169-2	Lifting gins
1	1	-	-	pç	FLV25726-1	Live work assembly
-	-	1	1	pç	FLV17173-1	Live work assembly
-	-	1	1	pç	FLV18158-1	Lower Mast
-	-	-	2	pç	FLV18158-2	Intermediary Mast
-	-	1	1	pç	FLV18158-5	Higher Mast
1	1	-	-	pç	FLV18158-3	Lower Mast
-	1	-	-	pç	FLV18158-4	Intermediary Mast
1	1	-	-	pç	FLV18158-6	Higher Mast
2	2	2	4	pç	FLV17172-1	Mast support bearing housing
1	1	1	1	pç	FLV18170-1	Moto-reductor
1	1	1	1	pç	FLV18161-1	Control box
1	1	-	-	pç	FLV25886-1	Switch-off storage
-	-	1	1	pç	FLV21133-1	Switch-off storage
1	1	1	1	pç	FLV21130-1	Gearmotor storage

GROUP L



Access our site.



DAYLIGHT WARNING SPHERES

Conventional Installation Esphere	218
Rope Installation Sphere	219
Helicopter Installation Sphere	220



DAYLIGHT WARNING SPHERES



They are designed for visual signalling in the air navigation of helicopters, airplanes, balloons, gliders, etc., preventing their collision with electric power transmission systems.

Due to the many situations and places where installing daytime warning spheres is necessary, specific installation models have been developed to minimize inconveniences caused by hard-to-reach places, rugged terrains and highway crossings, among others. NBR 7276 specifies the situations and locations where warning spheres are mandatory.

In compliance with electric utility requirements, warning spheres are built in accordance with the NBR 15237 standard and an exclusive manufacturing process, ensuring excellent properties such as:

- durability;
- ultraviolet resistance;
- wind vibration resistance;
- rotation resistance;
- slip resistance;
- rainwater drainage system through radial holes, perpendicular to the cable.

CONVENTIONAL INSTALLATION ESPHERE

These spheres are installed and removed manually, on the ground, during line construction or de-energized maintenance.

The conventional system consists of special aluminum alloy bearings, exclusive rubber pads for every cable diameter, as well as bolts, nuts, and washers.



Catalog Reference	Connection (mm)	Approx. Weight	
		kg	lb
ESR30700-1	6 a 9.5	5.60	12.36
ESR30700-2	9.51 a 12.5		
ESR30700-3	12.51 a 14.5		
ESR30700-4	14.51 a 16.5		
ESR30700-5	16.51 a 18.5		
ESR30700-6	18.51 a 20.5		
ESR30700-7	20.51 a 23.5		
ESR30700-8	23.51 a 25.5		

ROPE INSTALLATION SPHERE

Designed for convenience and productivity, it allows hot line installation and removal operations in steel, aluminum, or OPGW cables, from the ground, using of the rope operation kit ESR12981-1.

Catalog Reference	Connection (mm)	Approx. Weight	
		kg	lb
ESR19899-1	6 to 8	6.06	13.36
ESR19899-2	8.1 to 10		
ESR19899-3	10.1 to 12		
ESR19899-4	12.1 to 14		
ESR19899-5	14.1 to 16		
ESR19899-6	16.1 to 18		
ESR19899-7	18.1 to 20		
ESR19899-8	20.1 to 22		



ESR12981-1 - ROPE INSTALLATION KIT

Item	Quant.	Unit.	Catalog Reference	Description
01	1	pc	FLV03278-3	Aluminum snatch block
02	1	pc	ESR12963-1	Snatch block stick
03	6	pc	ESR11795-1	Rope insulated stick (Ø 6 x 1500 mm)
04	1	pc	ESR12591-1	Hooks
05	220	m	RM1895-1	Synthetic fiber rope



FLV03278-3



ESR12963-1

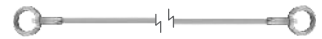

ESR11795-1



ESR12591-1

HELICOPTER INSTALLATION SPHERE

These spheres have a special cable opening and coupling mechanism, which is driven by a single eye bolt located at its top, which can be operated with a sphere installation hot stick. It is also provided with a counterweight to keep the eye bolt at the top of the sphere.

Hot line installation and removal is quickly and safely performed directly from a helicopter.



Catalog Reference	Connection (mm)	Approx. Weight	
		kg	lb
ESR19900-1	6 to 8	5.57	12.28
ESR19900-2	8.1 to 10		
ESR19900-3	10.1 to 12		
ESR19900-4	12.1 to 14		
ESR19900-5	14.1 to 16		
ESR19900-6	16.1 to 18		
ESR19900-7	18.1 to 20		
ESR19900-8	20.1 to 22		